

→ RECTANGULAR CIVIL FRAMES INSTALLATION GUIDES

There are methods which can be used to install Hawke Civil Frames, each method giving an inspectable professional finish to any cable/pipe penetration.

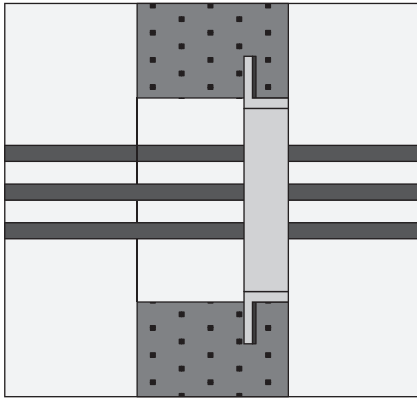

Figure 1

The frame can be casted directly into a wall or floor.

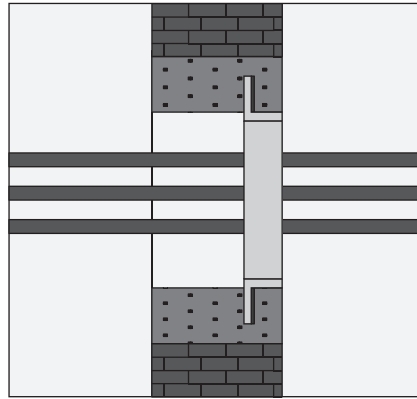

Figure 2

The frame may be cast into a concrete jacket. This method being normally used for brick and blockwork walls which in turn is fixed into the wall or floor.

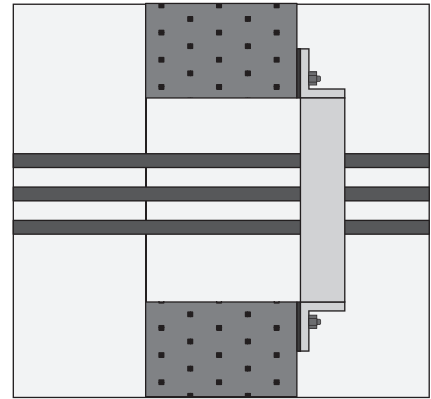

Figure 3

The frame can be bolted to wall and floors.

→ CASTED

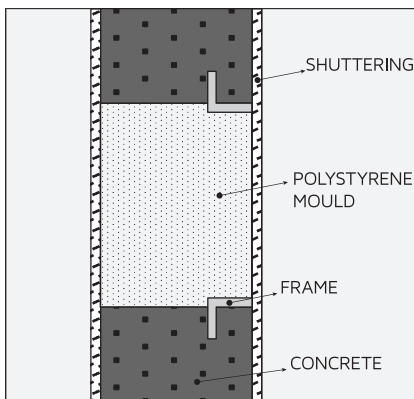

Figure 1

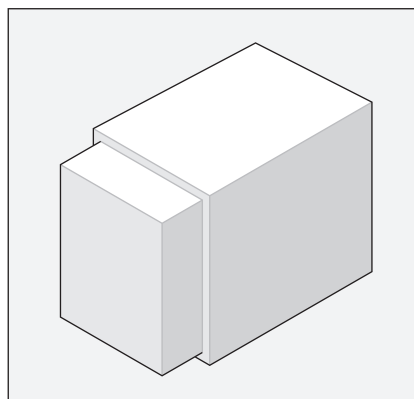

Figure 2

For hawke frames which are cast into a wall or floor it is recommended that a Hawke Polystyrene Mould is used. Hawke moulds are available to suit sizes 2, 4, 6 and 8 with 300mm lengths and may be cut to suit the deep of the wall or floor as required. (See catalogue page...79)

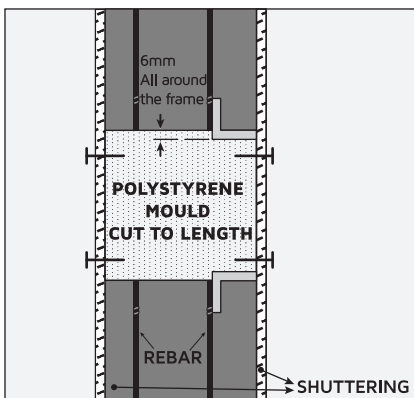

Figure 3

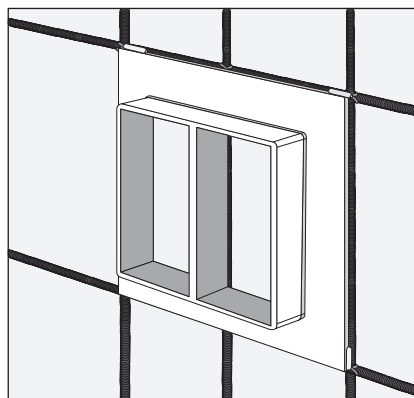

Figure 4

Frames and moulds require support to ensure that the correct position is maintained whilst the concrete is being poured. This may be achieved by nailing through the shuttering into the mould (if used) and fixing the frame to the rebar.

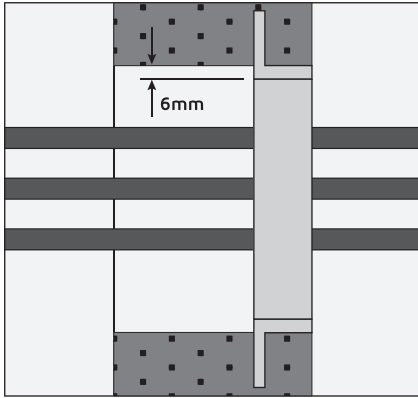

Figure 5

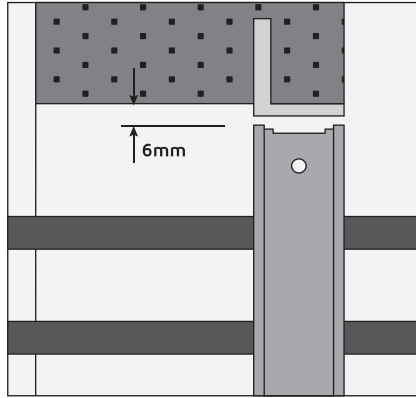

Figure 6

Stayplates and compression plates have retaining lugs. Clearance for these must be allowed when a frames are cast into a structure.

This allowance is 12mm and should be added to the total internal width of the frame to obtain the correct dimensions.

Hawke Moulds have this allowance built in.

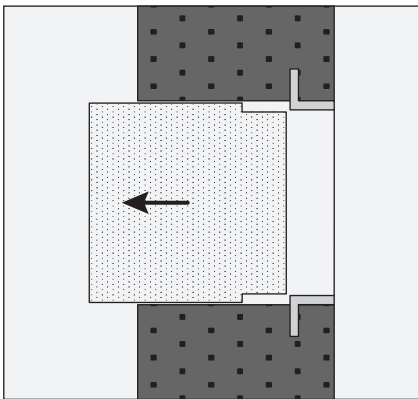

Figure 7

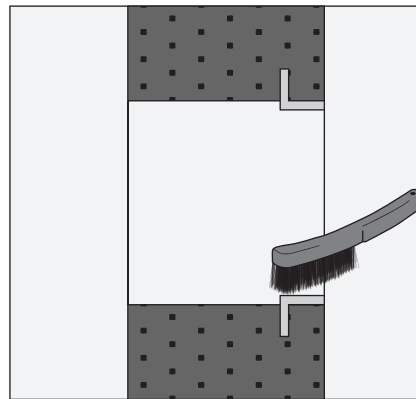

Figure 8

When all shuttering and other formwork has been removed, the polystyrene mould must be removed prior to electrical installation.

The transit aperture should be cleaned to remove any concrete or other debris that may have contaminated the apertures internal faces.

BOLTED

Frames can be bolted to floors and walls in either of the options showed below (HCOX frames, open version, can not be reverse fixed).

Stayplates and compression plates have retaining lugs, 6mm clearance is required to all sizes.

When frames are reverse fixed then 9mm clearance is required to all size frames.

For minimum aperture dimensions see table pag...145

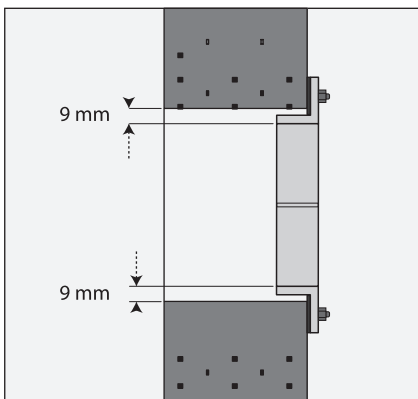

Figure 1.a

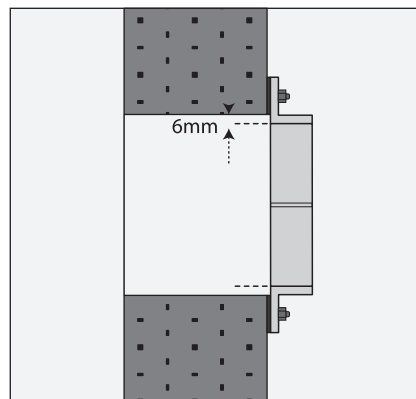

Figure 1.b

Size to fixing holes and type of fastener is to be established by the civil contractor dependent on size of frame weight and structure to which it is to be fixed.

When fixing frames to concrete/brick type structure care should be taken if using expanding type fixings as they could burst into the aperture.

BOLTED

For bolted installations Intumescent Mastic or Hawke Fireproof Silicone (See catalogue page 78) should be inserted between the frames flange and the structure.

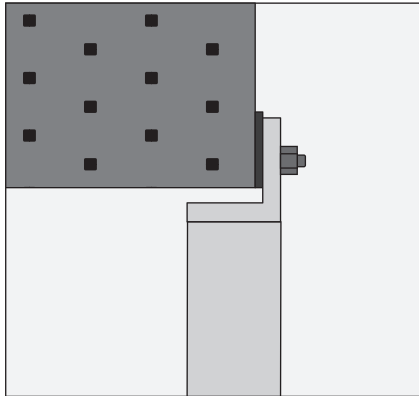

Figure 2.a

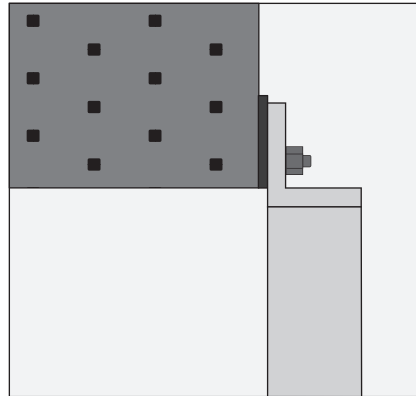

Figure 2.b

Each 300ml tube of Mastic/Silicone should be sufficient to mount and seal 3 individual frames or a multiple frame of up to 4 apertures.

Prior to application of sealant ensure that faces to be sealed are dry and free from grease and any loose material, ensure that transit frame mates up with any fixings/holes already present checking especially the apertures over which the frame is to be mounted. (See minimum aperture dimensions table).

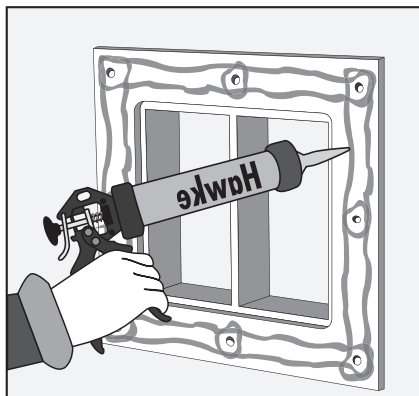

Figure 3.a

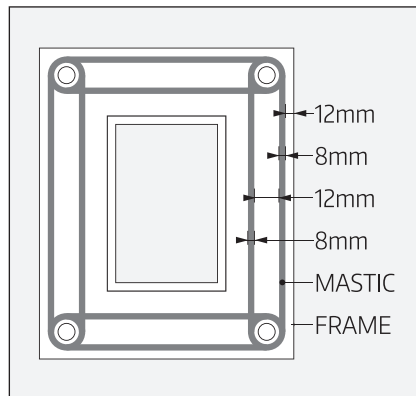

Figure 3.b

Cut nozzle on Mastic/Silicone tube to produce a bead diameter of approximately 8mm.

Apply two parallel rows of mastic and run a bead of mastic around each hole, as show below.

The Mastic/Silicone can be applied to front or rear of the frame dependant on the installation. See Fig.1 and Fig.2.

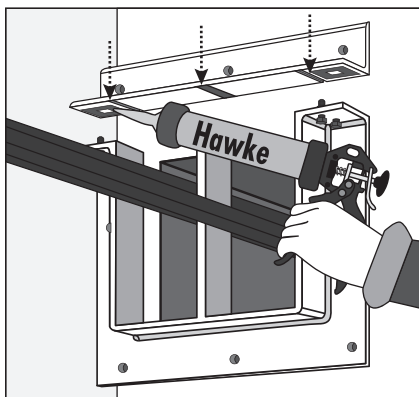

Figure 4.a

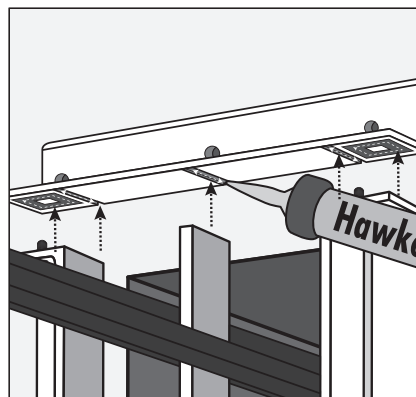

Figure 4.b

If HCOX open frame is used, Mastic/Silicone should be applied also in all bolting areas of the removable end as showed below.

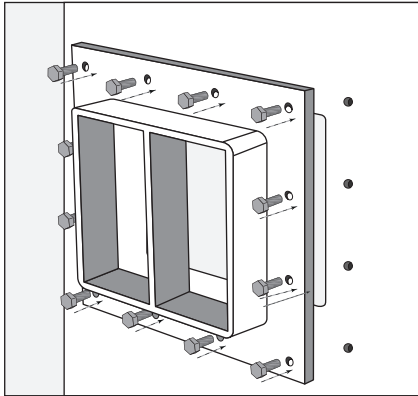

Figure 5

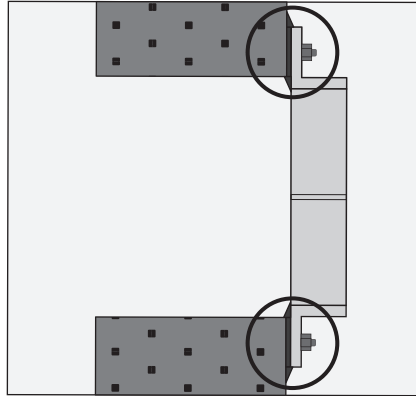

Figure 6

The frame can now be placed over its fixings and fasteners tightened to clamp the frame to the wall/floor.

When tightened up to the required amount, the Mastic/Silicone should be faced off to the frame leaving a fillet of Mastic/Silicone around external edges of the frame.

◆ → **BACKING PLATES**

Lightweight sheet steel backing plates are available to be used in conjunction with Hawke Civil Frames. Backing plates are produced in standard lengths for wall thickness of 60mm to 200mm for sizes 2,4,6 and 8, frames plus multiples there of, but specials can be made. Please state thickness of wall when ordering.

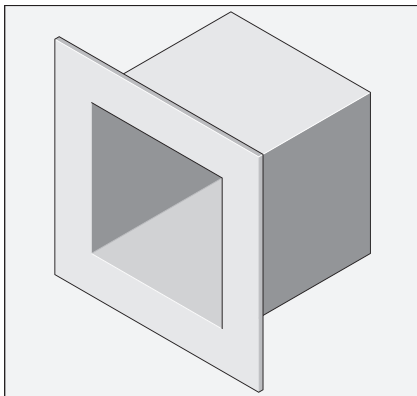

Figure 1.a

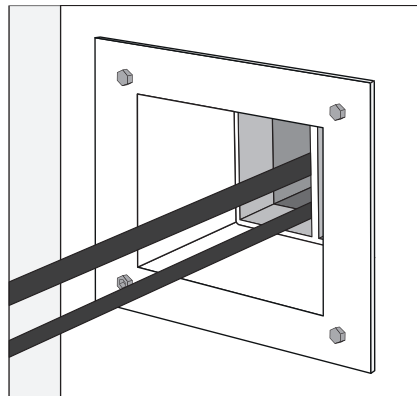

Figure 1.b

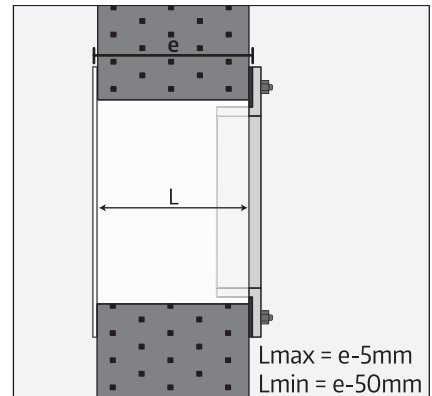

Figure 1.c

These maintain the openings through the wall and floors and add the finished appearance of the installation. It should be noted that the backing plates do not add to the fire resistance of a transit and should be not used to stop fire spread in cavity walls.

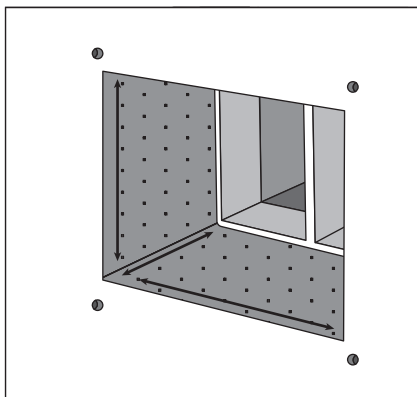

Figure 2.a

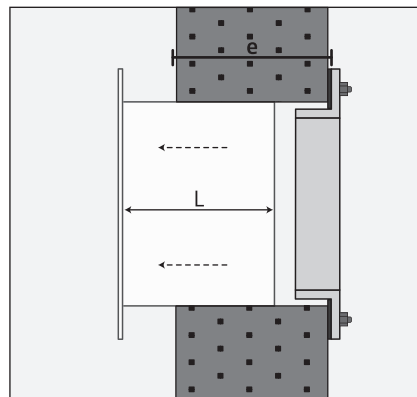

Figure 2.b

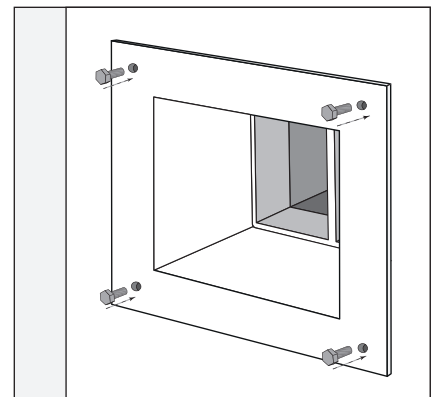

Figure 2.c

MINIMUM APERTURE DIMENSIONS WHEN FRAMES ARE CAST INTO OR BOLTED ONTO A WALL											
Frame Type	H (mm)	W (mm)									
		x 1	x 2	x 3	x 4	x 5	x 6	x 7	x 8	x 9	x 10
HCX 2 HCOX 2	119										
HCX 2+2 HCOX 2+2	230										
HCX 2+4 HCOX 2+4	288,5										
HCX 2+6 HCOX 2+6	347										
HCX 2+8 HCOX 2+8	405,5										
HCX 4 HCOX 4	177,5										
HCX 4+4 HCOX 4+4	347	138	268	398	528	658	788	918	1048	1178	1308
HCX 4+6 HCOX 4+6	405,5										
HCX 4+8 HCOX 4+8	464										
HCX 6 HCOX 6	236										
HCX 6+6 HCOX 6+6	464										
HCX 6+8 HCOX 6+8	522,5										
HCX 8 HCOX 8	294,5										
HCX 8+8 HCOX 8+8	581										

MINIMUM APERTURE DIMENSIONS WHEN FRAMES ARE CAST INTO OR BOLTED ONTO A WALL								
Frame Type	x 1		x N					For other HCLX frame styles and sizes please contact Hawke technical dept.
	H (mm)	W (mm)	W (mm)					
			x 2	x 3	x 4	x 5	x 6	
HCLX 180	236	198	388	578	768	958	1148	
HCLX 240	298	258	508	758	1008	1258	1508	
HCLX 360	458	378	748	1118	1488	1858	2228	

HTS-EN-AI013-Rev04-12/21