

→ **ROUND HRTO/HRT** standard installation and inspection checks guidelines:

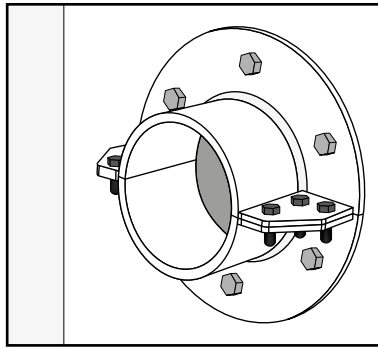

Check that Hawke Sleeve has been used in the installation, that it has been properly installed (welded/bolted) and that it has not mechanical or corrosion damage.

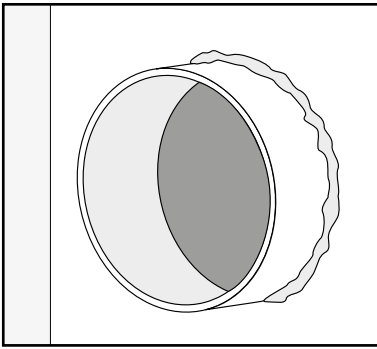
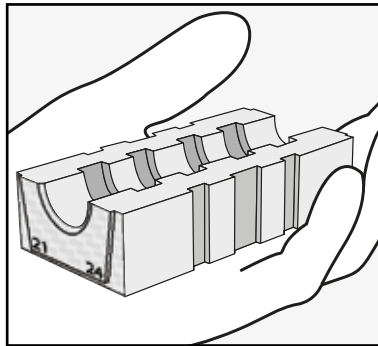
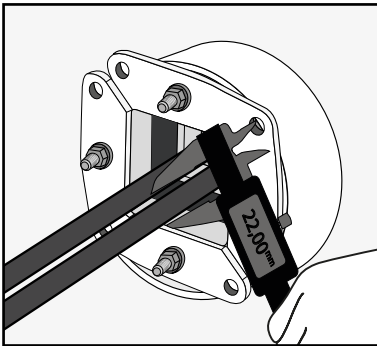

Measure the outer diameter of the cable and ensure that diameter is within the cable/pipe range marked on the front of the block or by the colour code of the block.

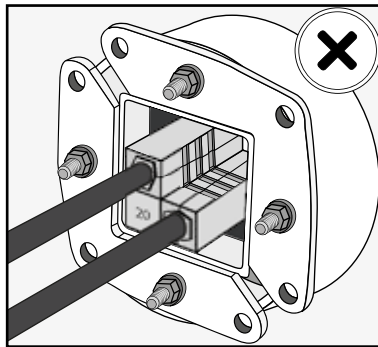
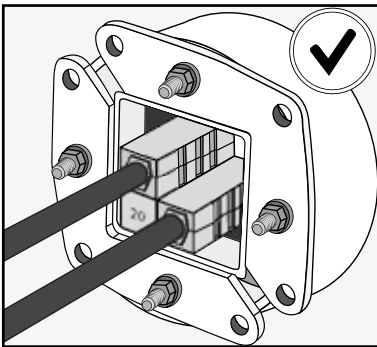

Check the correct orientation of the blocks.

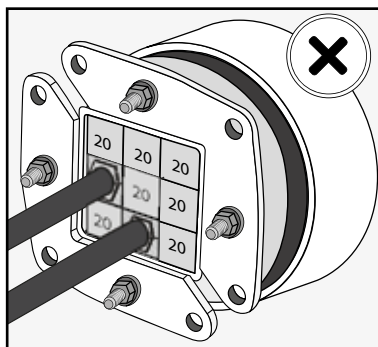
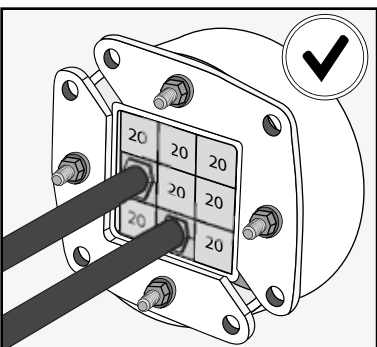

Check that the HRT/HRTO is completely inserted in the Sleeve/Aperture.

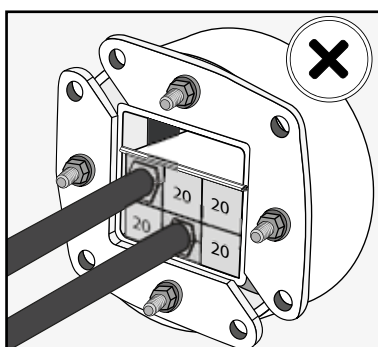
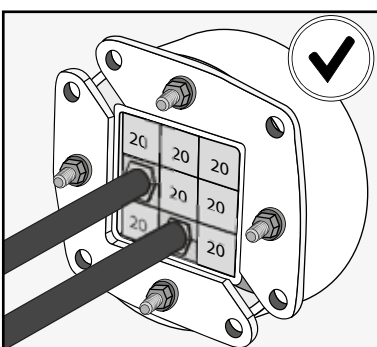

Check that stayplates have not be used in the installation.

Check that Hawke Lubricant has been used during the installation.

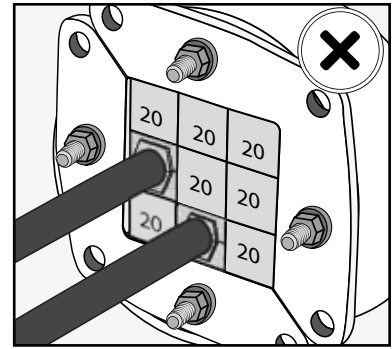
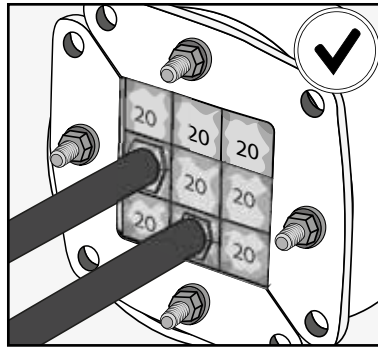

Check that front plates have been closed.

Check that there are sufficient blocks installed into the frame to cover the sealing area defined for each size of frame.

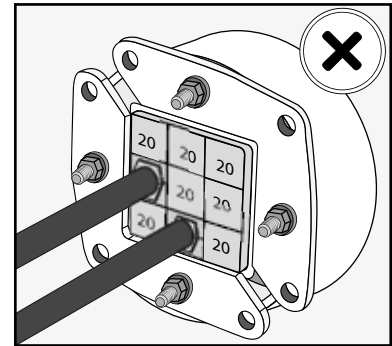
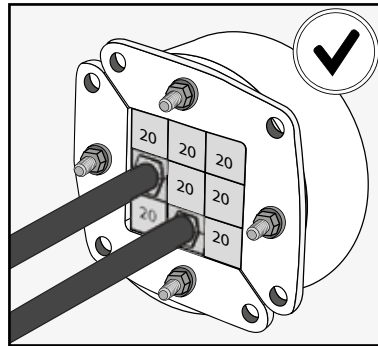

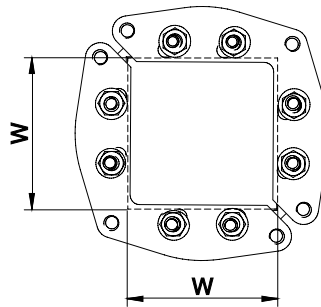

Check that there are sufficient blocks installed into the frame to cover the sealing area defined for each size of frame.

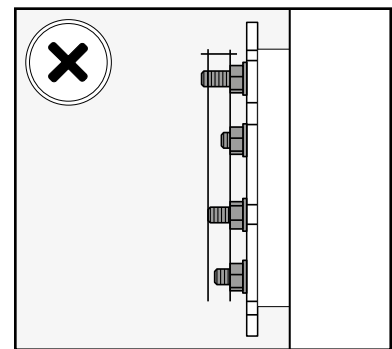
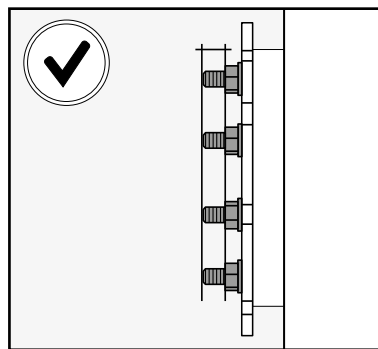

TYPE	SEALING AREA (mm)
HRTO-30	15x15
HRTO-40	20x20
HRTO-50	30x30
HRTO-70	40x40
HRTO-100	60x60
HRTO-125	80x80
HRTO-150	90x90
HRTO-200	120x120

Check that the right tightening of the bolts has been performed (approximately 10 mm of thread on each bolt should protrude from the nut).



 **Notes**

Leave the system at least 24 hour before apply pressure.

Check that there are sufficient blocks installed into the frame to cover the sealing area defined for each size of frame.