

→ **HRST ROUND SYSTEM** standard installation guide:

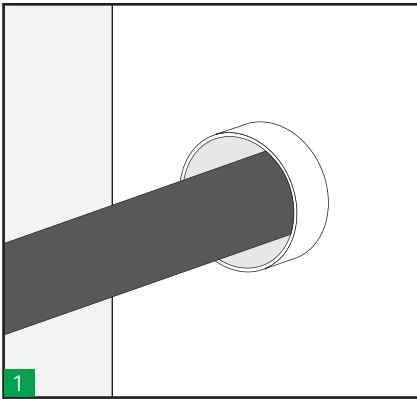

Check the inside diameter of the sleeve and the outside diameter of the cable/pipe to verify that it is within the range of selected HRST. Hawke HRST colour code will help for a correct selection.

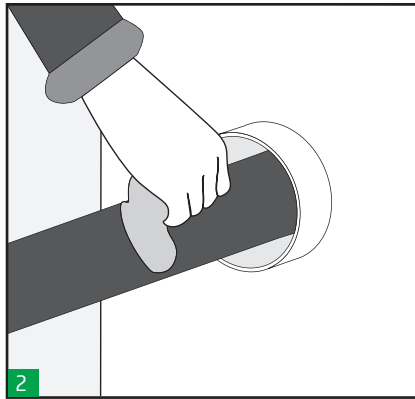

Make sure the pipe is properly centred in the sleeve. Make sure the sleeve and the cable/pipe are clean.

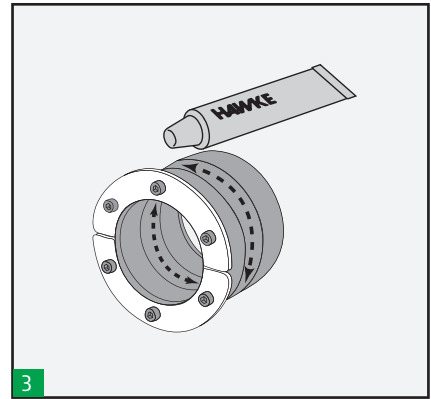

Lubricate the inside of the HRST to be in contact with the cable/ pipe and lightly lubricate the outside in contact with the sleeve.

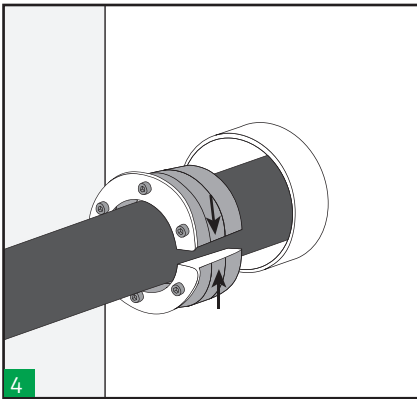

Open the HRST and install around the cable/pipe.

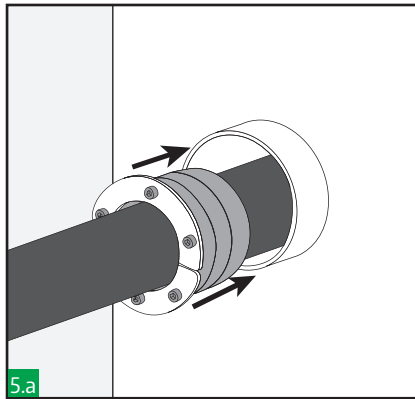

Insert the HRST into the sleeve. Check the HRST is completely inserted into the sleeve, front plates should be in contact with the sleeve.

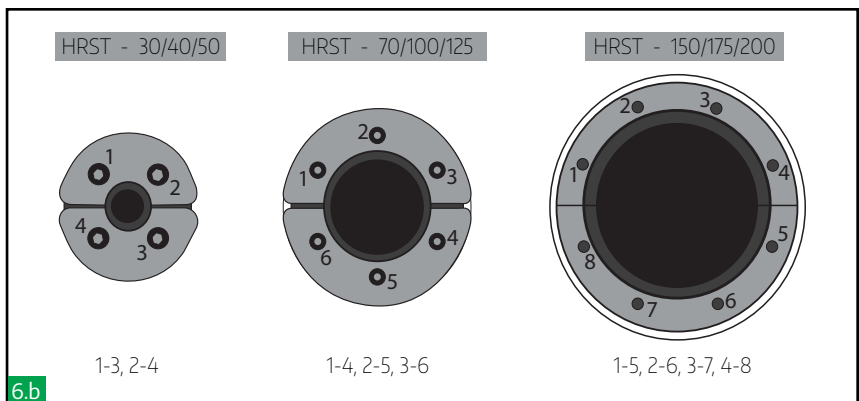
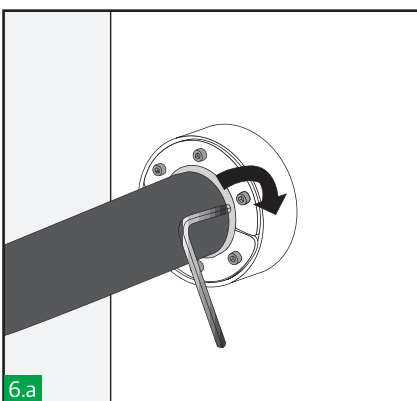
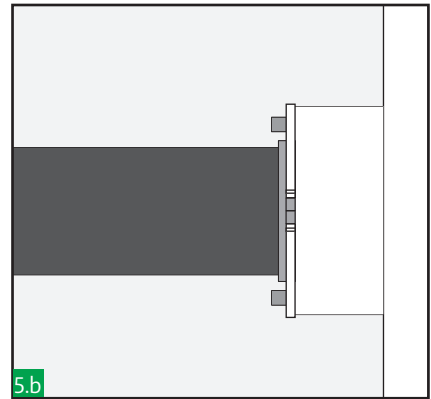

Tighten the bolts. Tightening must be done in one revolution step for each bolt following next sequence until the system is enough compressed to seal the cable/pipe.

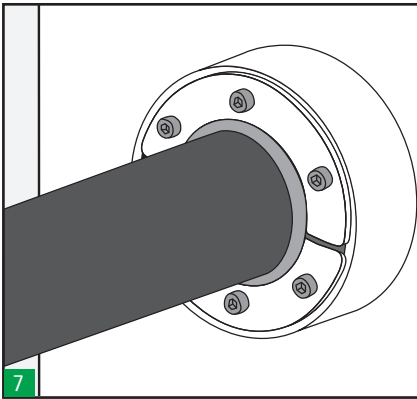

Make a visual inspection of the transit. HRST (colour code) selected match the pipe and sleeve installed, HRST is completely inserted into the sleeve, does not exist gaps between HRST and the cable/pipe.

DESCRIPTION	SLEEVE SIZE NEEDED	SEALING FROM (mm)	SEALING TO (mm)	COLOUR
HRST-30/4	30	4	10	White
HRST-30/7	30	7	14	Red
HRST-30/10	30	10	17	Blue
HRST-40/4	40	4	10	Purple
HRST-40/7	40	7	14	Yellow
HRST-40/10	40	10	17	Green
HRST-40/17	40	17	24	Pink
HRST-50/4	50	4	10	Red
HRST-50/10	50	10	17	White
HRST-50/17	50	17	24	Blue
HRST-50/24	50	24	30	Orange
HRST-70/26	70	26	33	Purple
HRST-70/33	70	33	39	Yellow
HRST-70/39	70	39	45	Green
HRST-70/45	70	45	50	Pink
HRST-100/48	100	48	55	Red
HRST-100/55	100	55	61	White
HRST-100/61	100	61	66	Blue
HRST-100/66	100	66	71	Orange
HRST-125/64	125	64	71	Purple
HRST-125/71	125	71	79	Yellow
HRST-125/79	125	79	86	Green
HRST-125/86	125	86	93	Pink
HRST-125/93	125	93	98	Orange
HRST-150/93	150	93	102	Red
HRST-150/102	150	102	108	White
HRST-150/108	150	108	115	Blue
HRST-150/115	150	115	120	Orange
HRST-175/118	175	118	125	Purple
HRST-175/125	175	125	132	Yellow
HRST-175/132	175	132	138	Green
HRST-175/138	175	138	145	Pink
HRST-200/136	200	136	143	Red
HRST-200/143	200	143	150	White
HRST-200/150	200	150	157	Blue
HRST-200/157	200	157	164	Orange
HRST-200/164	200	164	170	Yellow

*All dimensions are nominal values

◆ Notes
Leave the system at least 24 hours before applying pressure.

◆ Sealing Range
Check cable/pipe sealing range in HRST catalogue page 53.