

→ **HMOX** Welding installation guide:

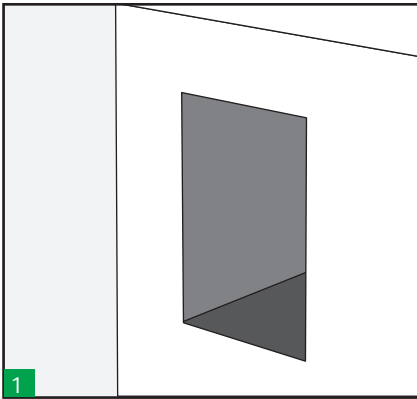

Ensure Hole cut is dimensionally in accordance with the standard HMX frames welding instructions

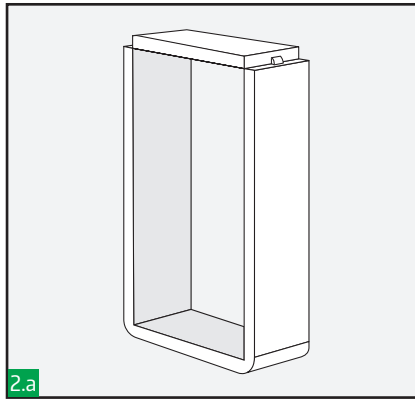

Break tack welds and remove end piece from the frame.

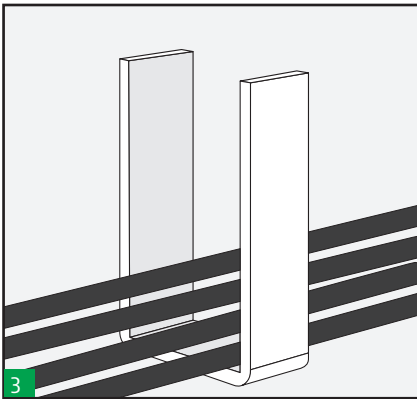
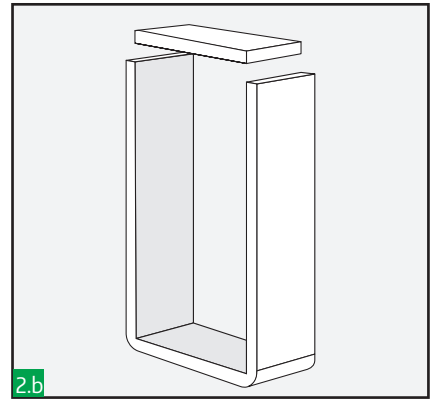

Place frame around cables. Tack weld end piece back into place. End piece should be centred in the lateral bars.

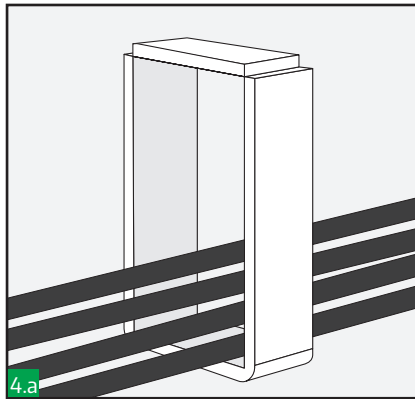

Tack weld end piece back into place. End piece should be centred in the lateral bars.

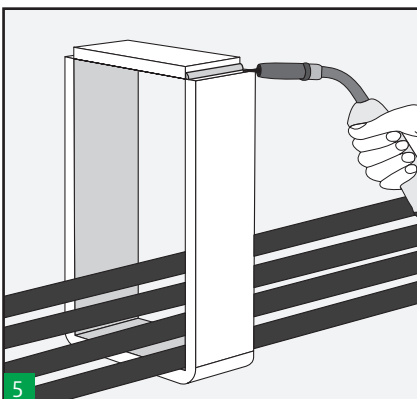
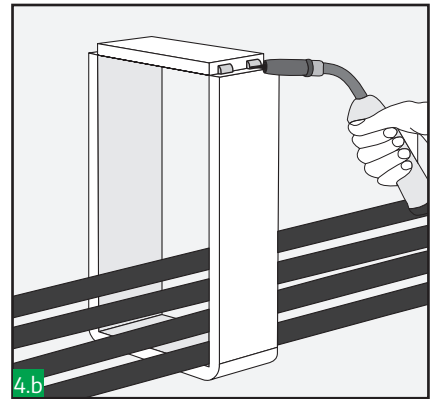

Run root fillet weld for full width of frame.

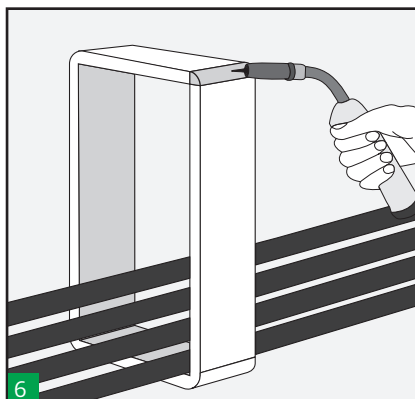

Final weld to form full radius at corners of frame.

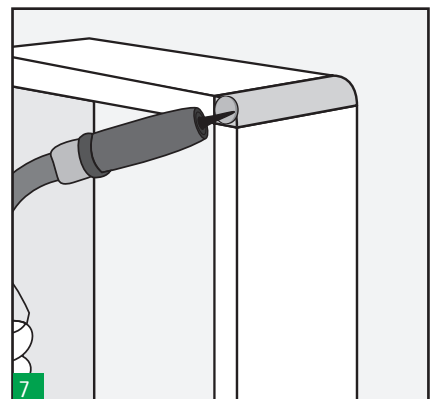

Clean both ends of weld/frame and spot weld them to ensure seal. Weld should not penetrate inside the corner of the frame.

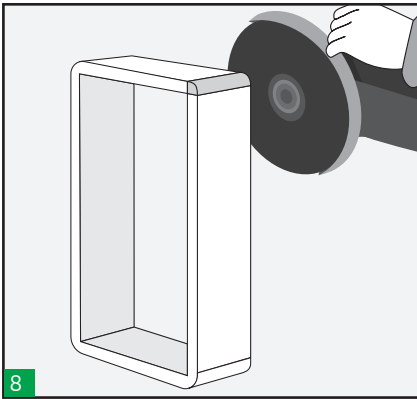

8

Dress welds.

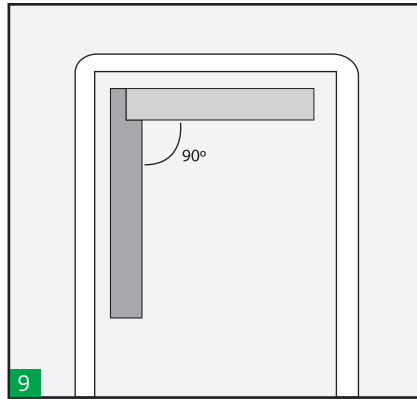

9

Check for squareness and parallelism.

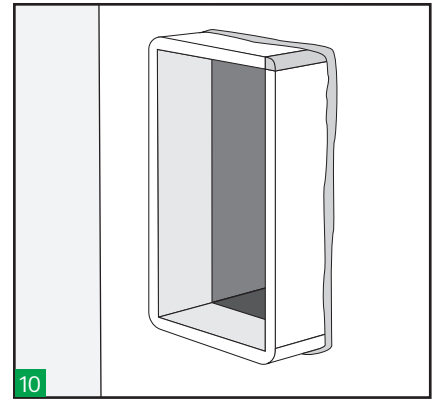

10

Weld frame in position in accordance with Rectangular frame HMX welding instructions and seal the frame in accordance to rectangular system installation guide.

◆ Notes

Leave the system at least 24 hours before apply pressure.
For disassembly see disassembly installation instructions.

◆ Sealing Area

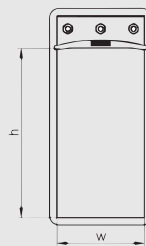

APERTURE SIZE	SEALING AREA (w x h)
1	60 x 60
2	120 x 60
3	60 x 120
4	120 x 120
5	60 x 180
6	120 x 180
7	60 x 240
8	120 x 240