

→ **COMPRESSION TOOL** Use guide:

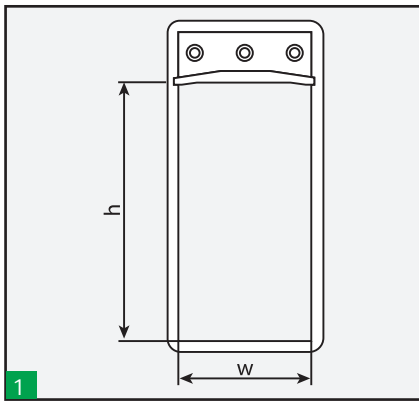

1 Before using the compression tool, it is important to check that the complete sealing area of this frame size (see table) is filled with blocks. Thus over tightening of the tool can be avoided.

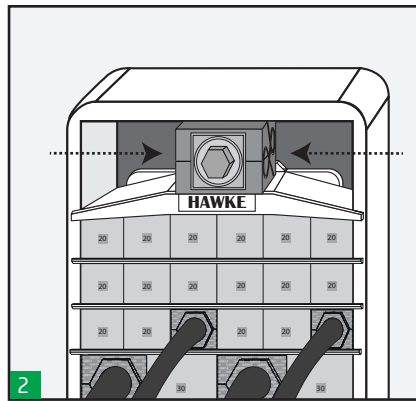

2 Compression tool must be introduced centred in the frame both in width and depth since otherwise the compression of the system would not be balanced so that to be able to introduce the lateral pieces of the endpacker it would be necessary to over tighten the tool and it could be damaged.

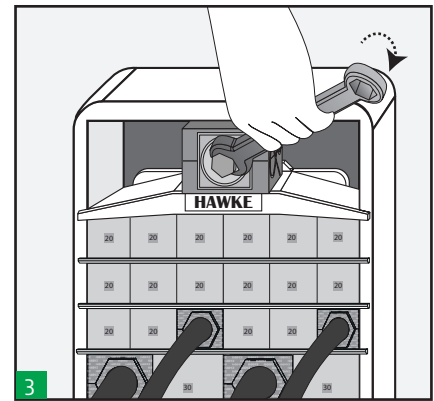

3 Once centred, we begin to tighten the compression tool which will be pressing on the compression plate.

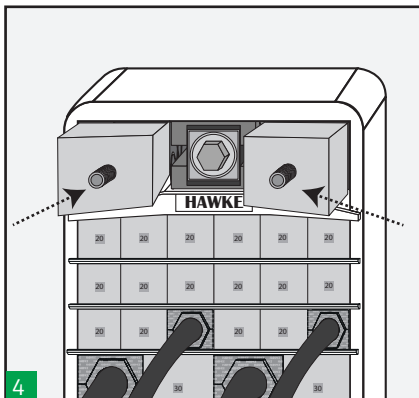

4 Before reaching the limit of tightening we must check if we have enough space to introduce the endpacker lateral pieces to avoid over tightening the tool that could block it.

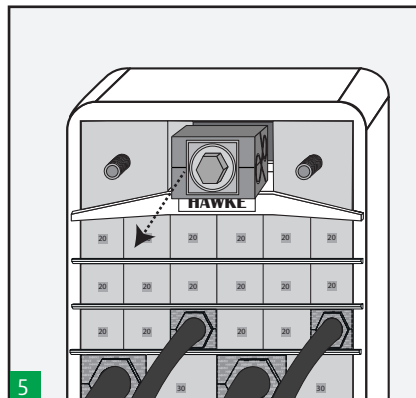

5 Insert the outer blocks of the endpacker. Then, untighten the compression tool and remove it.

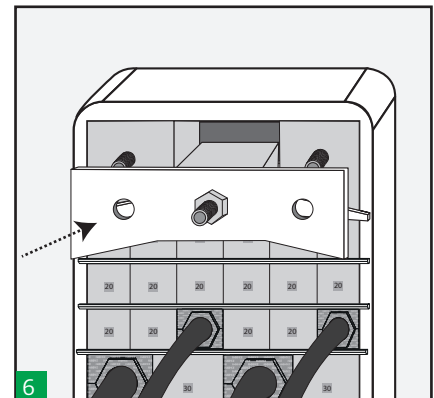

6 Insert the centre piece of the endpacker along with the front plate.

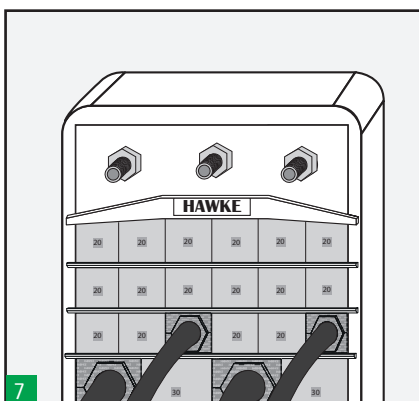

7 Tighten the nuts on the endpacker alternately following the above sequence to compress and complete the seal. Use a ratchet spanner for an easier installation. Approximately 10-12 mm of thread should protrude on each bolt to ensure the sealing.

◆ Recommendations of good use.

- Avoid damaging the compression tool by hitting it when you introduce it into the frame.
- Avoid dropping the tool.
- Avoid block the tool with an unnecessary over tighten.
- Grease the tool for a longer lifetime.

◆ Sealing Area.

APERTURE SIZE	SEALING AREA (w x h)
1	60 x 60
2	120 x 60
3	60 x 120
4	120 x 120
5	60 x 180
6	120 x 180
7	60 x 240
8	120 x 240