



HAWKE[®] | Transit System

**CABLE AND PIPE
PENETRATIONS
SEALING SYSTEM**

INDEX CONTENT

**ABOUT HAWKE
TRANSIT SYSTEM 4**

**MARINE
FRAMES..... 16**

HMX 18
HMOX 20
HMFY 22
HMFYB 24
HMEX 26
HMBX 28
HMCX 30
HMRX TB 32
DIMENSIONS 34
DRILLING 35

**CIVIL
FRAMES..... 38**

HCX 40
HCOX 42
HCLX 44
HCLOX 45
DIMENSIONS 46
DRILLING 47

**ROUND
TRANSITS 50**

HRTO 50
HRST 52

SLEEVES 56

C 56
CB 58
CBO 60
CBC 62

**ASSEMBLY
PARTS 66**

TOLERANT BLOCKS 66
WAVE GUIDES 67
BLANK BLOCKS 68
TREFOIL BLOCKS 69
SPECIAL INSERT BLOCKS 69
COMPRESSION SYSTEM 70
STAYPLATES 73

ACCESSORIES..... 76

COMPRESSION TOOL 76
PULLER 76
CLAMP TOOL 76
WELDING FIXING TOOL 77
LUBRICANT 77
SILICONE
FIREPROOF SEALANT 78
MASTIC 78
BACKING PLATE 79
POLYSTYRENE MOULD 79

**EMC TRANSIT
SYSTEMS..... 82**

EMC 82
BLOCKS 85
COMPRESSION SYSTEM 88
STAYPLATES 90
EMC ACCESSORIES 90
HRTO EMC 92
HRST EMC 94

DUCT SEAL 98

**CABINET
SEALS..... 102**

H-DM 102
CSDM 104
BLOCKS 105
STAYPLATES 106

ATEX..... 108

HDS..... 110

APP..... 111

**TECHNICAL
SUPPORT SERVICE 112**

**INSTALLATION GUIDES
INDEX..... 115**

RECTANGULAR SYSTEM..... 116
HMCX SYSTEM 118
HRTO/HRT
ROUND SYSTEM120
HRST ROUND SYSTEM.....122
HRST MULTIHOLE
ROUND SYSTEM 124
H-DM CABINET
SEAL SYSTEM..... 126
RECTANGULAR
EMC SYSTEM.....129
HMCX EMC SYSTEM 132
HRTO/HRT EMC
ROUND SYSTEM135
COMPRESSION TOOL 138
PULLER.....139
CLAMP TOOL140
RECTANGULAR CIVIL FRAMES
INSTALLATION GUIDES 141
CIVIL SLEEVES
INSTALLATION GUIDE..... 146

**WELDING
INSTALLATION GUIDES 150**

STANDARD WELDING
INSTRUCTIONS.....150
SLEEVES WELDING
INSTRUCTIONS..... 152
HMFx WELDING
INSTRUCTIONS..... 154
HMOX156

**INSTALLATION AND INSPECTION
CHECKS GUIDELINES:..... 158**

RECTANGULAR STANDARD ..158
ROUND HRTO/HRT 160
RECTANGULAR EMC.....162
ROUND EMC HRTO/HRT164
ROUND HRST STANDARD166
ROUND HRST MULTIHOLE....167

TEMPLATES 170

MARINE AND CIVIL RECTANGULAR
STANDARD170
ROUND CORNERS HMCX 171
CABINET SEAL H-DM172
ROUND TRANSITS HRTO173

ABOUT HAWKE TRANSIT SYSTEM

Founded in 1985, Hawke Transit System has a broad experience in Product Development, System Design, Manufacturing, Supply and Inspection.

Manufacturing meets the highest quality standards to coincide with our demanding industry certification requirements. Our products are 100% European manufactured.

Our products guarantee the integrity of cable and pipe penetrations through fire walls, decks or bulkheads. Our systems inhibit against risks from hazards such as; fire, smoke, water ingress, toxic gases and attack by vermin.

The **Hawke Transit System** offers cost effectiveness, speed of assembly, flexibility and total inspectability of the installation. Hawke Transit System sealing systems can be used in new installations as well as in old ones. (retrofit applications).

Acquired in 2005 by Fernández Jove Group, with headquarters in the North of Spain. Hawke Transit System has a global reach with offices and distributors all around the world.



Fernandez Jove Group has built a strong reputation throughout the World by adhering to our core values;

- ◆ Reliability
- ◆ Flexibility
- ◆ Excellence
- ◆ Teamwork
- ◆ Customer Commitment
- ◆ Innovation
- ◆ Respect

“A COMPANY TO RELY ON.”

WHAT IS A CABLE TRANSIT SYSTEM?

It is a means of sealing cables and pipes passing through a wall, floor, deck or bulkhead.

The **Hawke Transit System** will seal against and exhibit resistance to:

- ◆ Fire
- ◆ EMC
- ◆ Water
- ◆ Radiation
- ◆ Gas
- ◆ Chemicals
- ◆ Explosion
- ◆ Ultra Violet Light
- ◆ Smoke
- ◆ Vermin
- ◆ Noise

WHERE WOULD YOU USE A TRANSIT SYSTEM?

Wherever a wall, floor, deck or bulkhead is penetrated by a cable or pipe the occupants and integrity of the structure are exposed to risk from hazards such as fire and smoke, water ingress, toxic gases and attack by vermin.

- ◆ Ship Building
- ◆ National Defence Agencies
- ◆ Offshore Platforms
- ◆ Oil & Gas Refineries
- ◆ Nuclear Plants
- ◆ Tunnel Systems
- ◆ Floating Production Off-loading Vessel (FPSO)
- ◆ Offshore Renewables
- ◆ Datacentres
- ◆ Medical Equipment
- ◆ Laboratories
- ◆ Pharmaceutical Manufacturing
- ◆ Telecommunications
- ◆ Jet Engine Test Facilities



WHY USE HAWKE TRANSIT SYSTEM?



- ◆ Increased Safety
- ◆ Speed of Assembly
- ◆ Total Inspectability
- ◆ Cost Effectiveness
- ◆ Flexibility
- ◆ Quality and Certification

HAWKE TRANSIT CERTIFICATION AND TESTING

The Hawke Transit System has been designed to meet the exacting demands of some of the most onerous hazardous areas that can be expected on land and sea.

Hawke Transits has been tested under different International standards with respect to fire resistance, pressure blast withstands, explosion etc.

Also, Hawke Transit System has been tested for specific environments/ applications that require specialist test to be carried out, these include resistance to conditions including Shock, Vibration, EMC, Radiation, Vermin, Sound Insulation etc.

Company rigorous and comprehensive testing regime has resulted in an impressive list of test reports and certificates issues by test houses and certification bodies worldwide.





ADVANTAGES OF HAWKE TRANSIT SYSTEM

◆ **Speed of installation**

Due to the special design of HTS products, installation and inspection time can be over **50% less** than those products that require onsite modification.



◆ **No onsite modifications needed**

Modification of any product is a process that can lead to human error. When using blocks that have to be modified, the installation contractor must make the correct decision each time he or she modifies a block.

Indeed, on a large project where thousands of blocks have to be modified, the chance that they would all be modified correctly is unlikely. Errors in modification to any sealing block will result in the installation's integrity against; gas, water and fire protection being completely lost.

When using Hawke products, the installation process is very simple: select a specific **Tolerant** block and install it immediately onto the respective cable. The speed of installation dramatically reduces labour costs when compared to alternative products.

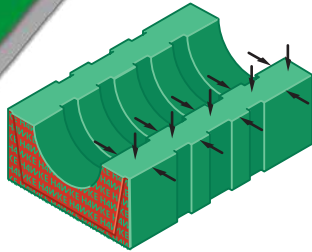

Also, HTS's colour-coding system removes the doubt by confirming that two correct halves are selected and installed on each cable.

◆ **Tolerant block size range**

Each block is manufactured incorporating five sealing faces and four sealing grooves along the internal faces, which are displaced by the sealing process.



This results in a **tolerance of up to 4mm** for cable/pipe diameters in the same block, without the need of any onsite modifications.

The five sealing faces allows for correct sealing of cables/pipes with an inconsistent outer diameter or shape. Services do not have to be completely circular to be sealed within our Tolerant Blocks.

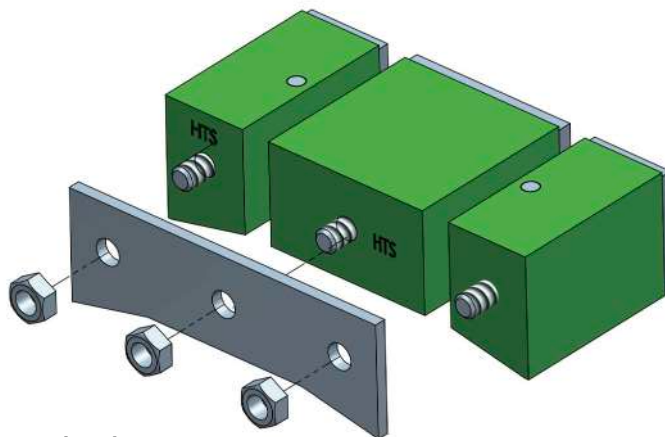

◆ **Three-part Endpacker**

With **Hawke Transit System's unique three-piece Endpacker** unit and HTS's compression tool, finishing the sealing of a Hawke Transit System is very simple and fast. The compression tool guarantees that there is always space to insert the endpacker, and its special design in three pieces allows it to be inserted without removing the tool, therefore without removing the pressure in the system.

This feature facilitates the installation and helps to reduce installation time.

Also, unique steel insert pins on both sides of the compression system, along with the compression plate, ensure that the correct level of compression is applied to each installation.

Compression is achieved by using our unique Compression Tool. The Compression System is reusable as it can be easily removed with our Puller Tool.

◆ **Total inspectability**

The individual block halves are clearly **colour-coded** and they also display the maximum and minimum diameter of cable/pipe which it is designated to seal.

The colour coding allows the inspector to clearly identify that the blocks have been correctly sized for the cable or pipe. Without colour-coding, it is extremely difficult to inspect/verify that the system has been installed correctly.



INCORRECT ASSEMBLY

Without colour coding incorrect assembly is impossible to detect.

CORRECT ASSEMBLY

Colour coded block halves provide visual confirmation of correct assembly.



INCORRECT ASSEMBLY

Mismatched colour coded block halves identify areas which have been incorrectly assembled.

◆ **No waste material**

Due to our Tolerant Blocks **not needing to be modified onsite**, there is therefore no scrap material to dispose of.

This means that potential hazards and hidden costs associated with the disposal of waste products are removed.



RECTANGULAR STANDARD TRANSIT SYSTEMS

Hawke marine and civil transit systems give protection to the cable/pipe entries wherever a wall, deck or bulkhead is penetrated by cable or pipe.

The transit system will maintain the integrity of the structure which is exposed to risks from hazards such as; fire, smoke, water ingress, toxic gases and attack by vermin.



Frame

Made of mild steel, stainless steel or aluminium, upon request special frame material can be manufactured; a Hawke frame is manufactured and finished to the highest quality.

Hawke frames can be cast within a concrete wall, cemented into a wall, bolted to a wall or welded or bolted to a metallic structure.

Compression System

The final element of the system installation, the Compression System is inserted at the top of the aperture.

The Compression System is used to apply and distribute compression throughout the system.

Stayplates

Each evenly packed row of blocks is held by a Stayplate.

There must be a Stayplate in contact with at least one side of the block to maintain the correct pressure rating for the system.

A stayplate is always between each layer of blocks, and never below the last bottom row of blocks.

Blank Filler Blocks

Made of the same material as our Tolerant Blocks, Filler Blocks also come in the same modular size range.

Filler Blocks are used to fill up unused space within the frame. This allows room for any future requirements.

Cable/Pipe Tolerant Blocks

Made of zero halogen, intumescent elastomeric polymer.

Each block accepts a range of cable/pipe diameters without the need of any modifications, enabling the complete range of standard sizes to be covered by a small number of blocks.

HTS's unique inspectable colour coding shows that the correct sizes of blocks are selected, avoiding installation mistakes and allowing easy inspection.

ROUND STANDARD TRANSIT SYSTEMS

HTS round transits effectively seal cables and pipes passing through circular apertures, giving protection against the same hazards as rectangular frames.

The seal is formed by tightening the compression bolts which expand the system radially, causing pressure to be exerted against the internal sleeve or aperture and closing down onto the interior services, blocks or pipes.

Round transits are installed within sleeves. HRTOs (with blocks, for multiple cables/pipes) and HRSTs (without blocks, for single cables/pipes).

HRST

Made of zero halogen, intumescent elastomeric polymer along with metal plates. The seal is formed by tightening the compression bolts which expand the system radially.

This applies pressure to the external and internal faces of the frame, creating an effective seal of the cable or pipe inside.

HRST frames are used to seal single cables or pipes. No blocks or stayplates are required. Each HRST frame has a wide sealing range without the need for any onsite modifications.

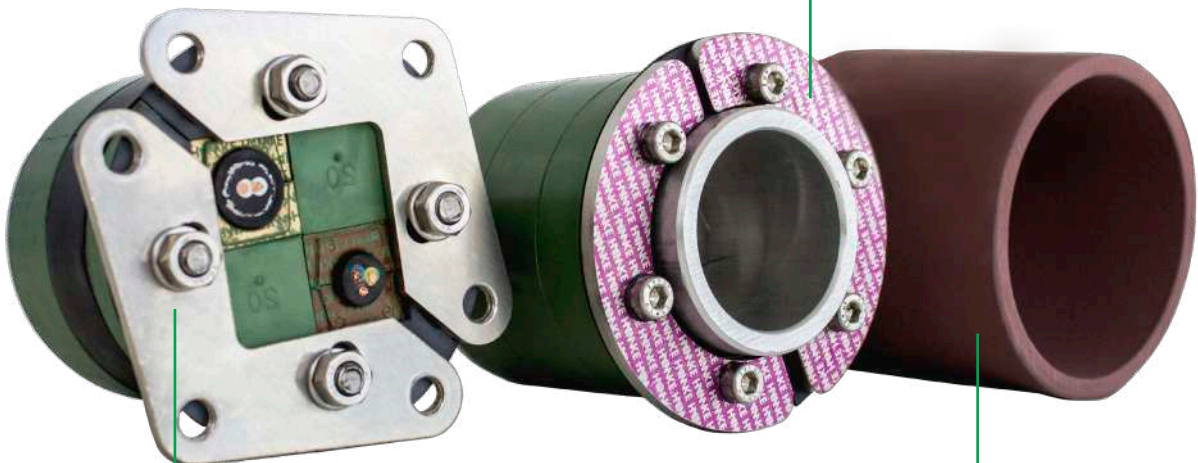

HRTO

Made of zero halogen, intumescent elastomeric polymer along with metal plates. The seal is formed by tightening the compression bolts which expand the system radially.

This applies pressure to the external and internal faces of the frame, creating an effective seal of the blocks and services inside. No Stayplates are needed in HRTO installations.

HRTO frames are typically used for multiple cables/pipes. Tolerant Blocks and Filler Blocks are needed to seal the frame.

Sleeves

Made of mild steel, stainless steel or aluminium; Hawke sleeves are manufactured and finished to the highest quality.

Hawke sleeves can be cast within a concrete wall, cemented into a wall, bolted to a wall or welded or bolted to a metallic structure.

EMC TRANSIT SYSTEMS

As well as acting as a certified fire, water and gas barrier (same as standard systems); the Hawke EMC Multi Cable Transit System (EMC MCT) eliminates stray airborne and cable screen signals/noise.

The stray signals/noise cannot pass through the conductive EMC MCT and will, instead, pass to earth.

This feature is essential to ensure the integrity of sensitive equipment and military/civil communication systems.

Conductive silver-loaded paint and copper tape provides a high conductive path from cable screen and block surface to the frame, and the aluminium or stainless-steel frame then allows conductivity from blocks to earth.

HTS EMC sealing systems are proved to be the best on the market, with the lowest installation times along with best results in EMI tests.

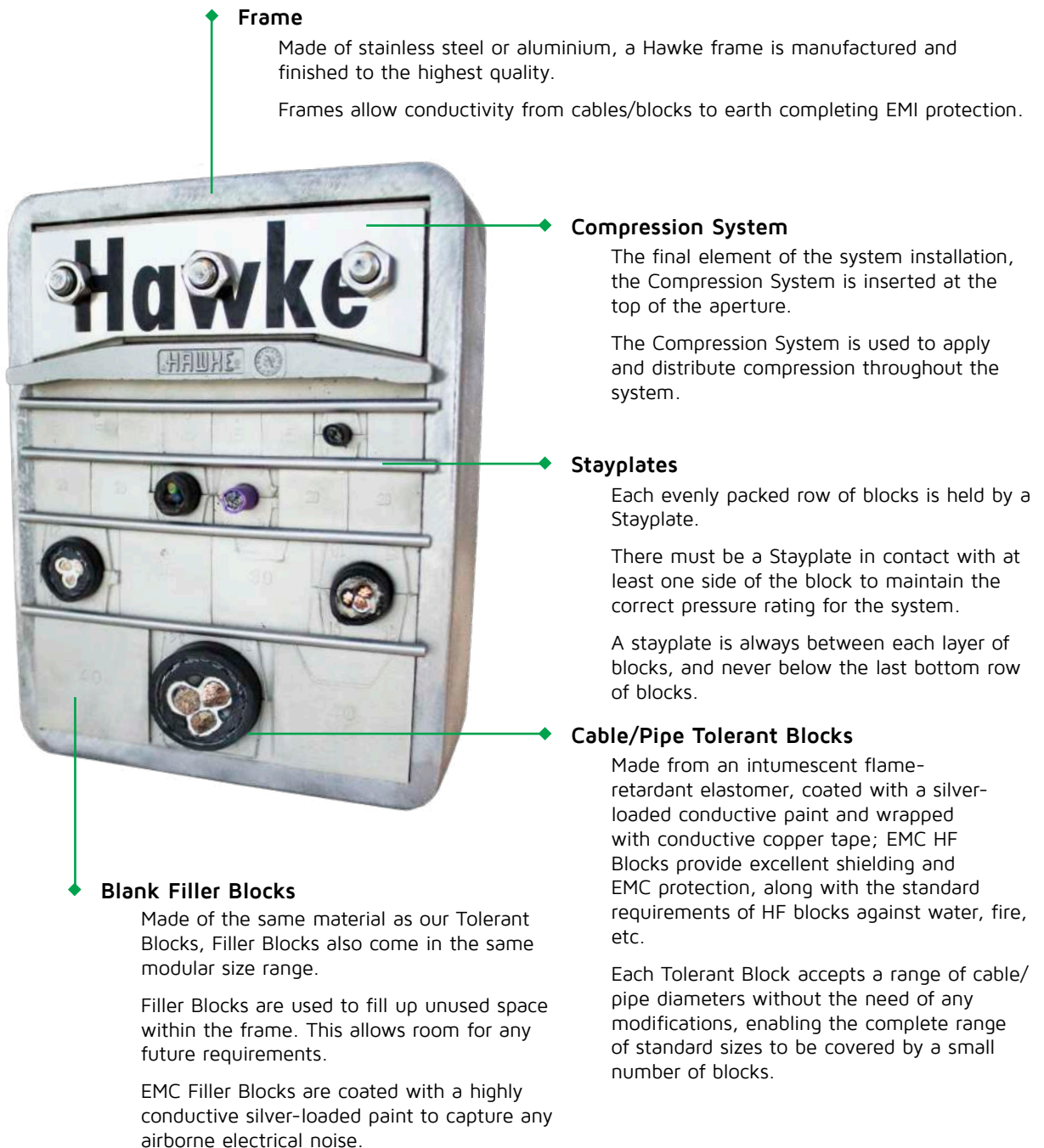

Frame

Made of stainless steel or aluminium, a Hawke frame is manufactured and finished to the highest quality.

Frames allow conductivity from cables/blocks to earth completing EMI protection.

Compression System

The final element of the system installation, the Compression System is inserted at the top of the aperture.

The Compression System is used to apply and distribute compression throughout the system.

Stayplates

Each evenly packed row of blocks is held by a Stayplate.

There must be a Stayplate in contact with at least one side of the block to maintain the correct pressure rating for the system.

A stayplate is always between each layer of blocks, and never below the last bottom row of blocks.

Cable/Pipe Tolerant Blocks

Made from an intumescent flame-retardant elastomer, coated with a silver-loaded conductive paint and wrapped with conductive copper tape; EMC HF Blocks provide excellent shielding and EMC protection, along with the standard requirements of HF blocks against water, fire, etc.

Each Tolerant Block accepts a range of cable/pipe diameters without the need of any modifications, enabling the complete range of standard sizes to be covered by a small number of blocks.

Blank Filler Blocks

Made of the same material as our Tolerant Blocks, Filler Blocks also come in the same modular size range.

Filler Blocks are used to fill up unused space within the frame. This allows room for any future requirements.

EMC Filler Blocks are coated with a highly conductive silver-loaded paint to capture any airborne electrical noise.

CABINET SEALING SYSTEMS H-DM

Hawke Cabinet Sealing Systems give IP protection to cable entries within an electrical cabinet/enclosure, avoiding water and dust to penetrate it thus protecting the equipment inside.

Its modular design allows modifications to be done exactly as in standard installations.

Using a H-DM is an easier and quicker alternative to using conventional gland plates.



Frame
Coated aluminium frame manufactured and finished to the highest quality.
Hawke frames for cabinet sealing systems are designed to be bolted.

Compression System
The final element of the system installation, the Compression System is inserted at the top of the aperture.
The Compression System is used to apply and distribute compression throughout the system.
Endpacker unit applies pressure to seal the system, without the need of compression plate or the use of any compression tools.

Stayplates
Each evenly packed row of blocks is held by a Stayplate.
There must be a Stayplate in contact with at least one side of the block to maintain the correct pressure rating for the system.

Blank Filler Blocks
Made of the same material as us Tolerant Blocks, Filler Blocks also come in the same modular size range.
Filler Blocks are used to fill up unused space within the frame. This allows room for any future requirements.

Cable/Pipe Tolerant Blocks
Made of zero halogen elastomeric polymer, each block accepts a range of cable/pipe diameters without the need of any modifications, enabling the complete range of standard sizes to be covered by a small number of blocks.
HTS's unique inspectable colour coding shows that the correct sizes of blocks are selected, avoiding installation mistakes and allowing easy inspection.



HAWKE

Transit System

www.HAWKE-HTS.COM

MARINE FRAMES

MARINE FRAMES

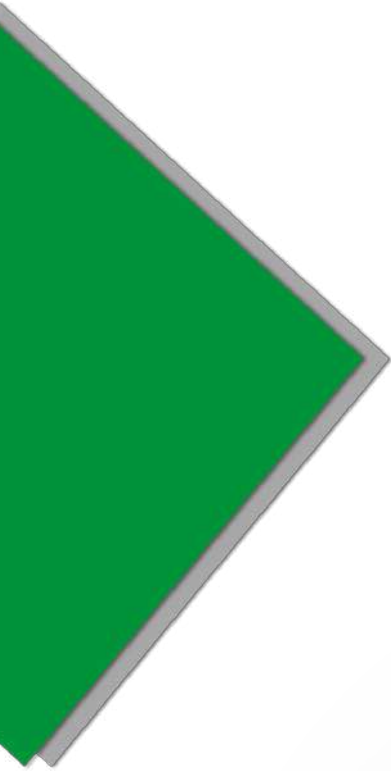

Marine frame with a 60mm flange to be welded to a metallic bulkhead or deck. - **HMX**

For standard applications, to be welded to a pre-cut metallic bulkhead or deck - **HMX**



Round corners frame to reduce the risk of cracks when there is a likelihood of stress on the corners of the frame. - **HMCX**



For high stressed area applications, end fillet pieces with radius corners are added to the HMX frame. - **HMRX TB**





Back to back frame for use when extra pressure and fire resistance are needed. HMBX is a double frame which is packed from both sides. - **HMBX**



HMX frame with removable end to be installed around existing cables or pipes. - **HMOX**

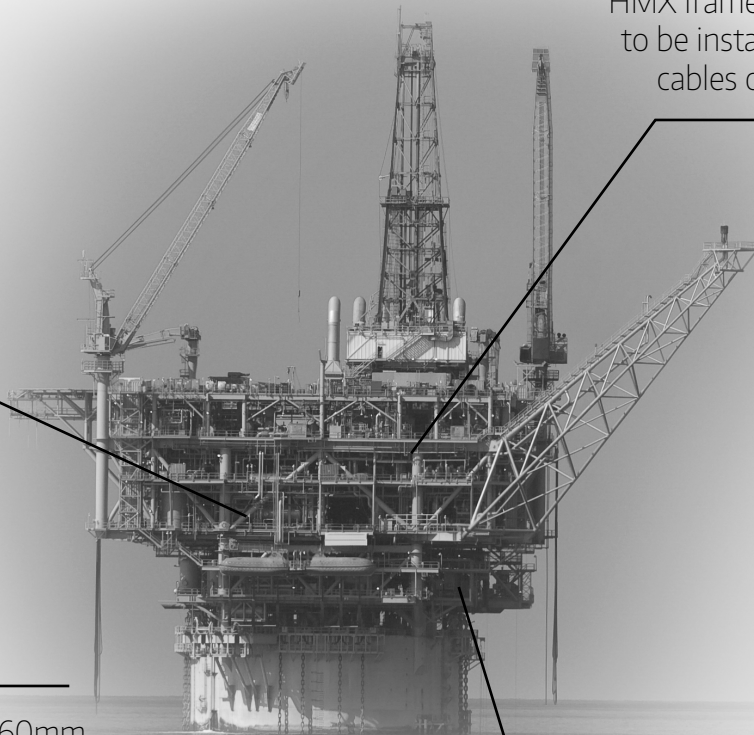

Marine frame with a 60mm flange to be bolted to a metallic bulkhead or deck. - **HMFBX**



A standard HMX frame extended using a welded collar. For use in corrugated bulkheads or to lift the frame above deck level - **HMEX**



HMX Frame

Rectangular frame for marine applications.
Made from 10mm thickness steel.

CHARACTERISTICS

- ◆ Available in four standard sizes with 120mm width (internal), 2,4,6,8 and in four standard sizes 60mm width (Internal), 1,3,5,7. Multiple frames are available as combination of two or more apertures arranged horizontally, vertically or both combined.
- ◆ Designed to be welded to a bulkhead or deck.
- ◆ Materials: Mild Steel, Stainless Steel.
Aluminium and other materials under request.
- ◆ To be sealed with standard or EMC HF blocks, compression systems and accessories.

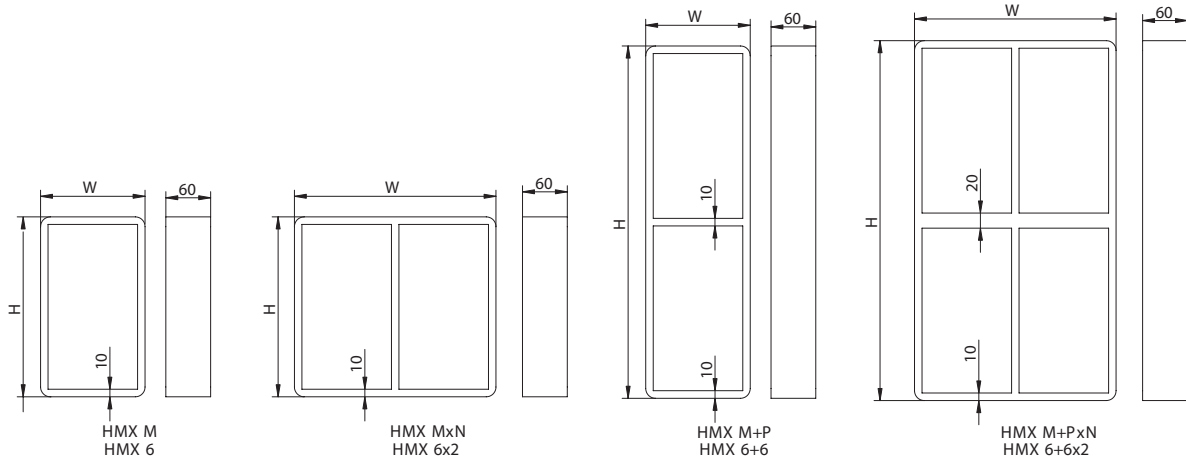

*Frame designation: M = size row 1; P = size row 2; N = number of columns.

DESCRIPTION	EXTERNAL DIMENSIONS (mm)		WEIGHT (Kg)	
	W	H	Mild Steel	Stainless Steel
HMX 1	80	121	1,6	1,6
HMX 2	140	121	2,2	2,3
HMX 2x2	271	121	3,9	4,0
HMX 2x3	401	121	5,6	5,7
HMX 2x4	531	121	7,3	7,5
HMX 2x5	662	121	9,0	9,2
HMX 2x6	792	121	10,7	11,0
HMX 3	80	179,5	2,2	2,3
HMX 4	140	179,5	2,7	2,8
HMX 4x2	271	179,5	4,7	4,8
HMX 4x3	401	179,5	6,7	6,9
HMX 4x4	531	179,5	8,7	8,9
HMX 4x5	662	179,5	10,6	10,9
HMX 4x6	792	179,5	12,6	12,9

*All dimensions are nominal values

HMX Frame

DESCRIPTION	EXTERNAL DIMENSIONS (mm)		WEIGHT (Kg)	
	W	H	Mild Steel	Stainless Steel
HMX 4+4	140	349	4,9	5,0
HMX 4+4x2	271	359	9,5	9,7
HMX 4+4x3	401	359	13,4	13,7
HMX 4+4x4	531	359	17,4	17,8
HMX 4+4x5	662	359	21,3	21,8
HMX 4+4x6	792	359	25,3	25,9
HMX 5	80	238	2,7	2,8
HMX 6	140	238	3,3	3,4
HMX 6x2	271	238	5,5	5,6
HMX 6x3	401	238	7,8	8,0
HMX 6x4	531	238	10,0	10,2
HMX 6x5	662	238	12,3	12,6
HMX 6x6	792	238	14,5	14,9
HMX 6+6	140	466	6,0	6,1
HMX 6+6x2	271	476	11,2	11,5
HMX 6+6x3	401	476	15,6	16,0
HMX 6+6x4	531	476	20,1	20,6
HMX 6+6x5	662	476	24,6	25,2
HMX 6+6x6	792	476	29,1	29,8
HMX 7	80	296,5	3,3	3,4
HMX 8	140	296,5	3,8	3,9
HMX 8x2	271	296,5	6,4	6,6
HMX 8x3	401	296,5	8,9	9,1
HMX 8x4	531	296,5	11,4	11,7
HMX 8x5	662	296,5	13,9	14,2
HMX 8x6	792	296,5	16,5	16,9
HMX 8+8	140	583	7,1	7,3
HMX 8+8x2	271	593	12,8	13,1
HMX 8+8x3	401	593	17,8	18,2
HMX 8+8x4	531	593	22,9	23,5
HMX 8+8x5	662	593	27,9	28,6
HMX 8+8x6	792	593	33,0	33,8

*For other sizes or frame combinations not presented here, contact sales department

*All dimensions are nominal values

→ Sealing Area

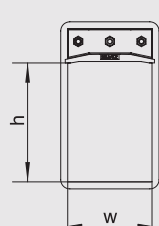

APERTURE SIZE	SEALING AREA (w x h)
1	60 x 60
2	120 x 60
3	60 x 120
4	120 x 120
5	60 x 180
6	120 x 180
7	60 x 240
8	120 x 240

→ Installation references

	page
See assembly parts	66
See accessories	76
See installation guide	116
See welding instructions	150
See inspection check	158

HMOX Frame

Rectangular frame for marine applications with removable end which allows to be installed around existing cables and pipes. Made from 10mm thickness steel.

CHARACTERISTICS

- ◆ Available in four standard sizes with 120mm width (internal), 2,4,6,8. Multiple frames are available as combination of two or more apertures arranged horizontally, vertically or both combined.
- ◆ Designed to be welded to a bulkhead or deck.
- ◆ Materials: Mild Steel, Stainless Steel.
Other materials under request.
- ◆ To be sealed with standard or EMC HF blocks, compression systems and accessories.

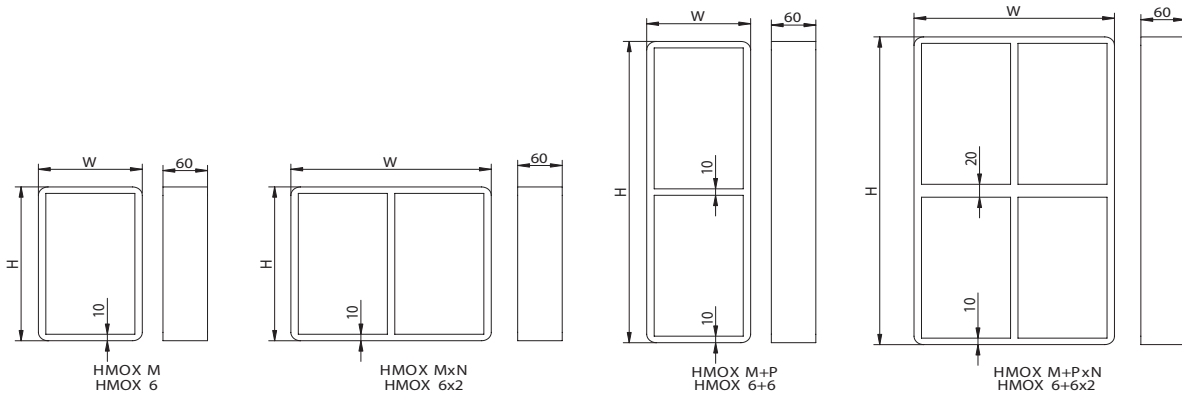

*Frame designation: M = size row 1; P = size row 2; N = number of columns.

DESCRIPTION	EXTERNAL DIMENSIONS (mm)		WEIGHT (Kg)	
	W	H	Mild Steel	Stainless Steel
HMOX 2	140	121	2,2	2,3
HMOX 2x2	271	121	3,9	4,0
HMOX 2x3	401	121	5,6	5,7
HMOX 2x4	531	121	7,3	7,5
HMOX 2x5	662	121	9,0	9,2
HMOX 2x6	792	121	10,7	11,0
HMOX 4	140	179,5	2,7	2,8
HMOX 4x2	271	179,5	4,7	4,8
HMOX 4x3	401	179,5	6,7	6,9
HMOX 4x4	531	179,5	8,7	8,9
HMOX 4x5	662	179,5	10,6	10,9
HMOX 4x6	792	179,5	12,6	12,9

*All dimensions are nominal values

HMOX Frame

DESCRIPTION	EXTERNAL DIMENSIONS (mm)		WEIGHT (Kg)	
	W	H	Mild Steel	Stainless Steel
HMOX 4+4	140	349	4,9	5,0
HMOX 4+4x2	271	359	9,5	9,7
HMOX 4+4x3	401	359	13,4	13,7
HMOX 4+4x4	531	359	17,4	17,8
HMOX 4+4x5	662	359	21,3	21,8
HMOX 4+4x6	792	359	25,3	25,9
HMOX 6	140	238	3,3	3,4
HMOX 6x2	271	238	5,5	5,6
HMOX 6x3	401	238	7,8	8,0
HMOX 6x4	531	238	10,0	10,2
HMOX 6x5	662	238	12,3	12,6
HMOX 6x6	792	238	14,5	14,9
HMOX 6+6	140	466	6,0	6,1
HMOX 6+6x2	271	476	11,2	11,5
HMOX 6+6x3	401	476	15,6	16,0
HMOX 6+6x4	531	476	20,1	20,6
HMOX 6+6x5	662	476	24,6	25,2
HMOX 6+6x6	792	476	29,1	29,8
HMOX 8	140	296,5	3,8	3,9
HMOX 8x2	271	296,5	6,4	6,6
HMOX 8x3	401	296,5	8,9	9,1
HMOX 8x4	531	296,5	11,4	11,7
HMOX 8x5	662	296,5	13,9	14,2
HMOX 8x6	792	296,5	16,5	16,9
HMOX 8+8	140	583	7,1	7,3
HMOX 8+8x2	271	593	12,8	13,1
HMOX 8+8x3	401	593	17,8	18,2
HMOX 8+8x4	531	593	22,9	23,5
HMOX 8+8x5	662	593	27,9	28,6
HMOX 8+8x6	792	593	33,0	33,8

*For other sizes or frame combinations not presented here, contact sales department

*All dimensions are nominal values

→ Sealing Area

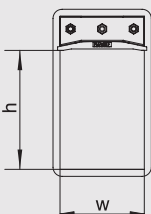

SIZE	SEALING AREA (w x h)
2	120x60
4	120x120
6	120x180
8	120x240

→ Installation references

	page
See assembly parts	66
See accessories	76
See installation guide	116
See welding instructions	156
See inspection check	158

HMFx Frame

Rectangular frame with flange for marine applications.
Made from 10mm thickness steel with a 60mm flange.

CHARACTERISTICS

- ◆ Available in four standard sizes with 120mm width (internal), 2, 4, 6, 8. Multiple frames are available as a combination of two or more apertures arranged horizontally, vertically or both combined. (*)
- ◆ Designed to be welded to a bulkhead or deck.
- ◆ Material: Mild Steel, Stainless Steel, Aluminium and other materials under request.
- ◆ To be sealed with standard or EMC HF blocks, compression systems and accessories.

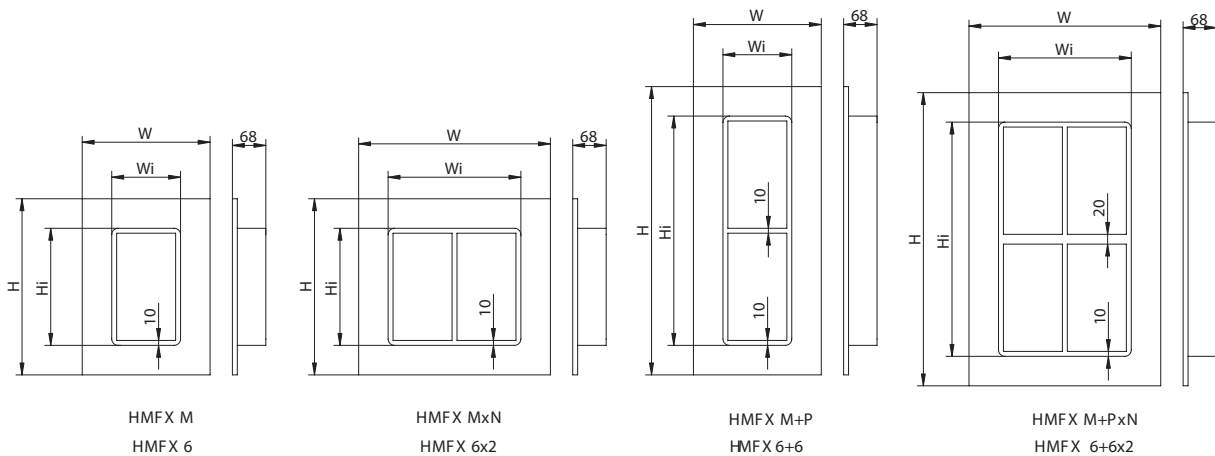

*Frame designation: M = size row 1; P = size row 2; N = number of columns.

DESCRIPTION	EXTERNAL DIMENSIONS (mm)				WEIGHT (Kg)	
	W	H	Wi	Hi	Mild Steel	Stainless Steel
HMFx 2	260	241	140	121	5,9	6,0
HMFx 2x2	391	241	271	121	8,7	8,9
HMFx 2x3	521	241	401	121	11,6	11,9
HMFx 2x4	651	241	531	121	14,5	14,9
HMFx 2x5	782	241	662	121	17,5	17,9
HMFx 2x6	912	241	792	121	20,4	20,9
HMFx 4	260	299,5	140	179,5	6,9	7,1
HMFx 4x2	391	299,5	271	179,5	10,1	10,3
HMFx 4x3	521	299,5	401	179,5	13,3	13,6
HMFx 4x4	651	299,5	531	179,5	16,5	16,9
HMFx 4x5	782	299,5	662	179,5	19,7	20,2
HMFx 4x6	912	299,5	792	179,5	22,9	23,4

*All dimensions are nominal values

HMFx Frame

DESCRIPTION	EXTERNAL DIMENSIONS (mm)				WEIGHT (Kg)	
	W	H	Wi	Hi	Mild Steel	Stainless Steel
HMFx 4+4	260	469	140	349	10,6	10,9
HMFx 4+4x2	391	479	271	359	16,6	17,0
HMFx 4+4x3	521	479	401	359	21,7	22,3
HMFx 4+4x4	651	479	531	359	26,9	27,6
HMFx 4+4x5	782	479	662	359	32,1	32,8
HMFx 4+4x6	912	479	792	359	37,2	38,1
HMFx 6	260	358	140	238	8,0	8,2
HMFx 6x2	391	358	271	238	11,5	11,7
HMFx 6x3	521	358	401	238	14,9	15,3
HMFx 6x4	651	358	531	238	18,4	18,9
HMFx 6x5	782	358	662	238	21,9	22,4
HMFx 6x6	912	358	792	238	25,3	26,0
HMFx 6+6	260	586	140	466	12,8	13,2
HMFx 6+6x2	391	596	271	476	19,3	19,8
HMFx 6+6x3	521	596	401	476	25,0	25,6
HMFx 6+6x4	651	596	531	476	30,7	31,5
HMFx 6+6x5	782	596	662	476	36,5	37,4
HMFx 6+6x6	912	596	792	476	42,2	43,2
HMFx 8	260	416,5	140	296,5	9,1	9,3
HMFx 8x2	391	416,5	271	296,5	12,8	13,1
HMFx 8x3	521	416,5	401	296,5	16,6	17,0
HMFx 8x4	651	416,5	531	296,5	20,3	20,8
HMFx 8x5	782	416,5	662	296,5	24,1	24,7
HMFx 8x6	912	416,5	792	296,5	27,8	28,5
HMFx 8+8	260	703	140	583	15,0	15,4
HMFx 8+8x2	391	713	271	593	22,1	22,6
HMFx 8+8x3	521	713	401	593	28,3	29,0
HMFx 8+8x4	651	713	531	593	34,6	35,4
HMFx 8+8x5	782	713	662	593	40,9	41,9
HMFx 8+8x6	912	713	792	593	47,1	48,3

*For other sizes or frame combinations not presented here, contact sales department

*All dimensions are nominal values

→ Sealing Area

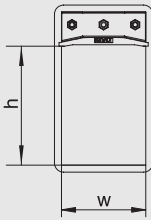

SIZE	SEALING AREA (w x h)
2	120x60
4	120x120
6	120x180
8	120x240

→ Installation references

	page
See assembly parts	66
See accessories	76
See installation guide	116
See welding instructions	154
See inspection check	158

HMFBX Frame

Rectangular frame with drilled flange for marine applications. Made from 10mm thickness steel with a 60mm flange.

CHARACTERISTICS

- ◆ Available in four standard sizes with 120mm width (internal), 2,4,6,8. Multiple frames are available as combination of two or more apertures arranged horizontally, vertically or both combined.
- ◆ Designed to be bolted to a bulkhead or deck.
- ◆ Materials: Mild Steel, Stainless Steel. Other materials under request.
- ◆ To be sealed with standard or EMC HF blocks, compression systems and accessories.

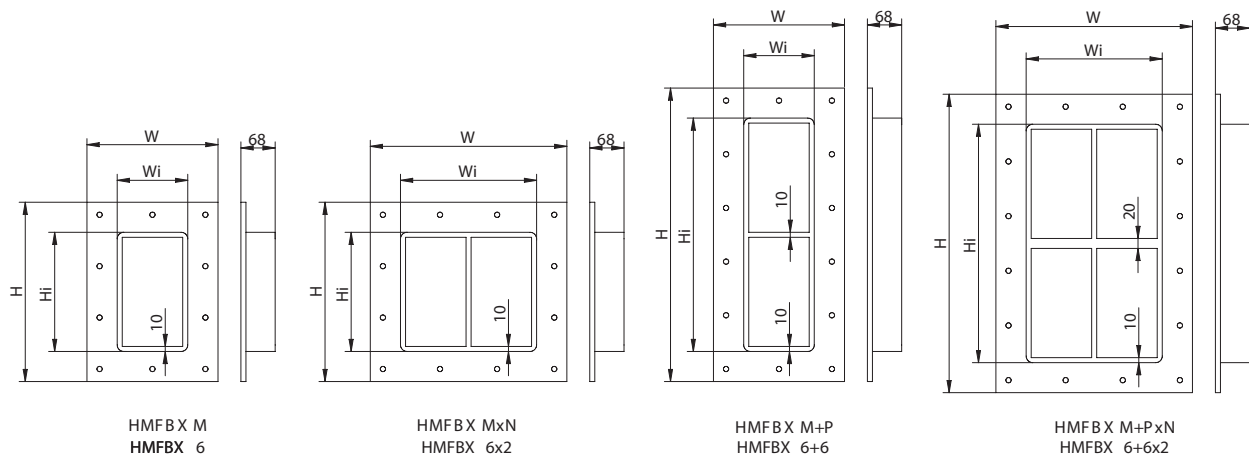

*Frame designation: M = size row 1; P = size row 2; N = number of columns.

DESCRIPTION	EXTERNAL DIMENSIONS (mm)				HOLE DISTANCE (mm)		WEIGHT (Kg)	
	W	H	Wi	Hi	X	Y	Mild Steel	Stainless Steel
HMFBX 2	260	241	140	121	105	96	5,9	6,0
HMFBX 2x2	391	241	271	121	113	96	8,7	8,9
HMFBX 2x3	521	241	401	121	94	96	11,6	11,9
HMFBX 2x4	651	241	531	121	100	96	14,5	14,9
HMFBX 2x5	782	241	662	121	91	96	17,5	17,9
HMFBX 2x6	912	241	792	121	96	96	20,4	20,9
HMFBX 4	260	299,5	140	179,5	105	83	6,9	7,1
HMFBX 4x2	391	299,5	271	179,5	113	83	10,1	10,3
HMFBX 4x3	521	299,5	401	179,5	94	83	13,3	13,6
HMFBX 4x4	651	299,5	531	179,5	100	83	16,5	16,9
HMFBX 4x5	782	299,5	662	179,5	91	83	19,7	20,2
HMFBX 4x6	912	299,5	792	179,5	96	83	22,9	23,4

*All dimensions are nominal values

HMFBX Frame

DESCRIPTION	EXTERNAL DIMENSIONS (mm)				HOLE DISTANCE (mm)		WEIGHT (Kg)	
	W	H	Wi	Hi	X	Y	Mild Steel	Stainless Steel
HMFBX 4+4	260	469	140	349	105	105	10,6	10,9
HMFBX 4+4x2	391	479	271	359	113	107	16,6	17,0
HMFBX 4+4x3	521	479	401	359	118	107	21,7	22,3
HMFBX 4+4x4	651	479	531	359	100	107	26,9	27,6
HMFBX 4+4x5	782	479	662	359	104	107	32,1	32,8
HMFBX 4+4x6	912	479	792	359	108	107	37,2	38,1
HMFBX 6	260	358	140	238	105	103	8,0	8,2
HMFBX 6x2	391	358	271	238	113	103	11,5	11,7
HMFBX 6x3	521	358	401	238	94	103	14,9	15,3
HMFBX 6x4	651	358	531	238	100	103	18,4	18,9
HMFBX 6x5	782	358	662	238	91	103	21,9	22,4
HMFBX 6x6	912	358	792	238	96	103	25,3	26,0
HMFBX 6+6	260	586	140	466	105	107	12,8	13,2
HMFBX 6+6x2	391	596	271	476	113	109	19,3	19,8
HMFBX 6+6x3	521	596	401	476	118	109	25,0	25,6
HMFBX 6+6x4	651	596	531	476	100	109	30,7	31,5
HMFBX 6+6x5	782	596	662	476	104	109	36,5	37,4
HMFBX 6+6x6	912	596	792	476	108	109	42,2	43,2
HMFBX 8	260	416,5	140	296,5	105	92	9,1	9,3
HMFBX 8x2	391	416,5	271	296,5	113	92	12,8	13,1
HMFBX 8x3	521	416,5	401	296,5	94	92	16,6	17,0
HMFBX 8x4	651	416,5	531	296,5	100	92	20,3	20,8
HMFBX 8x5	782	416,5	662	296,5	91	92	24,1	24,7
HMFBX 8x6	912	416,5	792	296,5	96	92	27,8	28,5
HMFBX 8+8	260	703	140	583	105	109	15,0	15,4
HMFBX 8+8x2	391	713	271	593	113	111	22,1	22,6
HMFBX 8+8x3	521	713	401	593	118	111	28,3	29,0
HMFBX 8+8x4	651	713	531	593	100	111	34,6	35,4
HMFBX 8+8x5	782	713	662	593	104	111	40,9	41,9
HMFBX 8+8x6	912	713	792	593	108	111	47,1	48,3

*For other sizes or frame combinations not presented here, contact sales department

*All dimensions are nominal values

→ Sealing Area

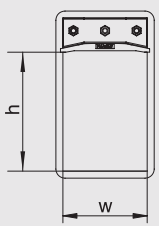

SIZE	SEALING AREA (w x h)
2	120x60
4	120x120
6	120x180
8	120x240

→ Installation references

	page
See assembly parts	66
See accessories	76
See installation guide	116
See inspection check	158

HMAX Frame

Standard HMX frame extended using a 10mm thick welded collar. For use in corrugated bulkhead or to fit the frame above deck level.

CHARACTERISTICS

- ◆ Available in four standard sizes with 120mm width (internal), 2,4,6,8. Multiple frames are available as combination of two or more apertures arranged horizontally, vertically or both combined.
- ◆ Designed to be welded onto a bulkhead or deck.
- ◆ Materials: Mild Steel, Stainless Steel.
Other materials under request.
- ◆ To be sealed with standard or EMC HF blocks, compression systems and accessories.

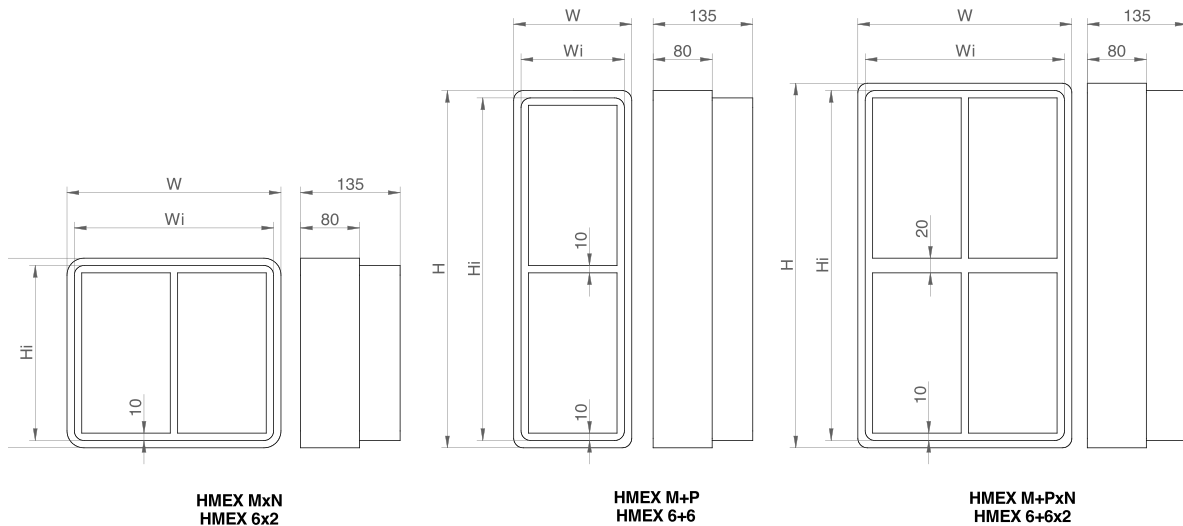

*Frame designation: M = size row 1; P = size row 2; N = number of columns.

DESCRIPTION	EXTERNAL DIMENSIONS (mm)				WEIGHT (Kg)	
	W	H	Wi	Hi	Mild Steel	Stainless Steel
HMAX 2	160	141	140	121	5,5	5,7
HMAX 2x2	291	141	271	121	8,9	9,1
HMAX 2x3	421	141	401	121	12,2	12,5
HMAX 2x4	551	141	531	121	15,5	15,9
HMAX 2x5	682	141	662	121	18,8	19,3
HMAX 2x6	812	141	792	121	22,2	22,7
HMAX 4	160	199,5	140	179,5	6,8	7,0
HMAX 4x2	291	199,5	271	179,5	10,4	10,7
HMAX 4x3	421	199,5	401	179,5	14,0	14,4
HMAX 4x4	551	199,5	531	179,5	17,6	18,0
HMAX 4x5	682	199,5	662	179,5	21,2	21,7
HMAX 4x6	812	199,5	792	179,5	24,8	25,4

*All dimensions are nominal values

HMEX Frame

DESCRIPTION	EXTERNAL DIMENSIONS (mm)				WEIGHT (Kg)	
	W	H	Wi	Hi	Mild Steel	Stainless Steel
HMEX 4+4	160	369	140	349	11,3	11,6
HMEX 4+4x2	291	379	271	359	17,6	18,1
HMEX 4+4x3	421	379	401	359	23,2	23,8
HMEX 4+4x4	551	379	531	359	28,8	29,5
HMEX 4+4x5	682	379	662	359	34,4	35,2
HMEX 4+4x6	812	379	792	359	39,9	40,9
HMEX 6	160	258	140	238	8,1	8,3
HMEX 6x2	291	258	271	238	12,0	12,3
HMEX 6x3	421	258	401	238	15,8	16,2
HMEX 6x4	551	258	531	238	19,7	20,2
HMEX 6x5	682	258	662	238	23,6	24,2
HMEX 6x6	812	258	792	238	27,5	28,2
HMEX 6+6	160	486	140	466	13,8	14,2
HMEX 6+6x2	291	496	271	476	20,8	21,3
HMEX 6+6x3	421	496	401	476	26,9	27,5
HMEX 6+6x4	551	496	531	476	33,0	33,8
HMEX 6+6x5	682	496	662	476	39,1	40,1
HMEX 6+6x6	812	496	792	476	45,2	46,4
HMEX 8	160	316,5	140	296,5	9,4	9,6
HMEX 8x2	291	316,5	271	296,5	13,5	13,9
HMEX 8x3	421	316,5	401	296,5	17,7	18,1
HMEX 8x4	551	316,5	531	296,5	21,8	22,4
HMEX 8x5	682	316,5	662	296,5	26,0	26,6
HMEX 8x6	812	316,5	792	296,5	30,1	30,9
HMEX 8+8	160	603	140	583	16,4	16,8
HMEX 8+8x2	291	613	271	593	23,9	24,5
HMEX 8+8x3	421	613	401	593	30,5	31,3
HMEX 8+8x4	551	613	531	593	37,2	38,1
HMEX 8+8x5	682	613	662	593	43,9	45,0
HMEX 8+8x6	812	613	792	593	50,6	51,8

*For other sizes or frame combinations not presented here, contact sales department

*All dimensions are nominal values

→ Sealing Area

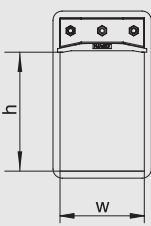

SIZE	SEALING AREA (w x h)
2	120x60
4	120x120
6	120x180
8	120x240

→ Installation references

	page
See assembly parts	66
See accessories	76
See installation guide	116
See welding instructions	150
See inspection check	158

HMBX Frame

Double frame for applications with increased pressure ratings and fire-proofing.

CHARACTERISTICS

- ◆ Available in four standard sizes with 120mm width (internal), 2,4,6,8. Multiple frames are available as combination of two or more apertures arranged horizontally, vertically or both combined.
- ◆ Designed to be welded onto a bulkhead or deck.
- ◆ Materials: Mild Steel, Stainless Steel.
Other materials under request.
- ◆ To be sealed with standard or EMC HF blocks, compression systems and accessories.

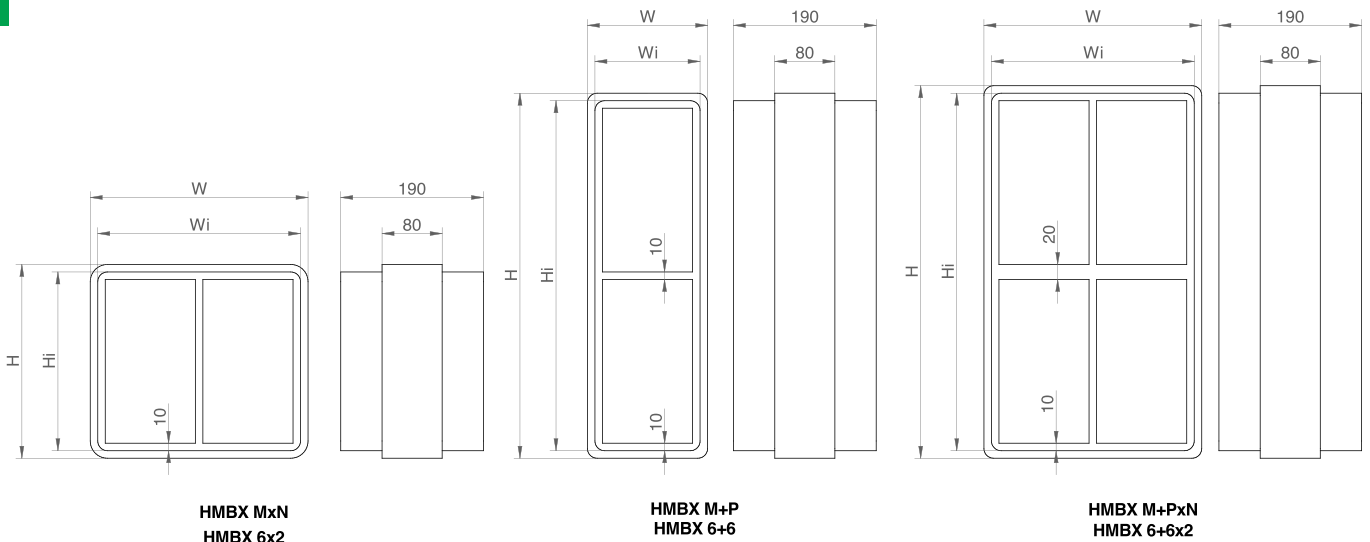

*Frame designation: M = size row 1; P = size row 2; N = number of columns.

DESCRIPTION	EXTERNAL DIMENSIONS (mm)				WEIGHT (Kg)	
	W	H	Wi	Hi	Mild Steel	Stainless Steel
HMBX 2	160	141	140	121	7,7	7,9
HMBX 2x2	291	141	271	121	12,7	13,1
HMBX 2x3	421	141	401	121	17,8	18,2
HMBX 2x4	551	141	531	121	22,8	23,4
HMBX 2x5	682	141	662	121	27,8	28,5
HMBX 2x6	812	141	792	121	32,8	33,6
HMBX 4	160	199,5	140	179,5	9,6	9,8
HMBX 4x2	291	199,5	271	179,5	15,1	15,5
HMBX 4x3	421	199,5	401	179,5	20,7	21,2
HMBX 4x4	551	199,5	531	179,5	26,3	26,9
HMBX 4x5	682	199,5	662	179,5	31,8	32,6
HMBX 4x6	812	199,5	792	179,5	37,4	38,3

*All dimensions are nominal values

HMBX Frame

DESCRIPTION	EXTERNAL DIMENSIONS (mm)				WEIGHT (Kg)	
	W	H	Wi	Hi	Mild Steel	Stainless Steel
HMBX 4+4	160	369	140	349	16,2	16,6
HMBX 4+4x2	291	379	271	359	27,1	27,8
HMBX 4+4x3	421	379	401	359	36,7	37,6
HMBX 4+4x4	551	379	531	359	46,2	47,3
HMBX 4+4x5	682	379	662	359	55,7	57,1
HMBX 4+4x6	812	379	792	359	65,2	66,8
HMBX 6	160	258	140	238	11,4	11,7
HMBX 6x2	291	258	271	238	17,5	17,9
HMBX 6x3	421	258	401	238	23,6	24,2
HMBX 6x4	551	258	531	238	29,8	30,5
HMBX 6x5	682	258	662	238	35,9	36,8
HMBX 6x6	812	258	792	238	42,0	43,0
HMBX 6+6	160	486	140	466	19,9	20,3
HMBX 6+6x2	291	496	271	476	31,9	32,7
HMBX 6+6x3	421	496	401	476	42,5	43,6
HMBX 6+6x4	551	496	531	476	53,1	54,5
HMBX 6+6x5	682	496	662	476	63,8	65,3
HMBX 6+6x6	812	496	792	476	74,4	76,2
HMBX 8	160	316,5	140	296,5	13,2	13,5
HMBX 8x2	291	316,5	271	296,5	19,9	20,4
HMBX 8x3	421	316,5	401	296,5	26,6	27,2
HMBX 8x4	551	316,5	531	296,5	33,2	34,1
HMBX 8x5	682	316,5	662	296,5	39,9	40,9
HMBX 8x6	812	316,5	792	296,5	46,6	47,7
HMBX 8+8	160	603	140	583	23,5	24,1
HMBX 8+8x2	291	613	271	593	36,7	37,6
HMBX 8+8x3	421	613	401	593	48,4	49,6
HMBX 8+8x4	551	613	531	593	60,1	61,6
HMBX 8+8x5	682	613	662	593	71,8	73,6
HMBX 8+8x6	812	613	792	593	83,5	85,6

*For other sizes or frame combinations not presented here, contact sales department

*All dimensions are nominal values

→ Sealing Area

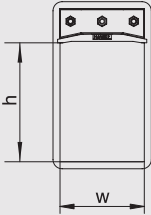

SIZE	SEALING AREA (w x h)
2	120x60
4	120x120
6	120x180
8	120x240

→ Installation references

	page
See assembly parts	66
See accessories	76
See installation guide	116
See welding instructions	150
See inspection check	158

HMCX Frame

Rectangular frame with round corners to reduce the risk of stress fractures within stress applications.

Made from 10mm thickness steel.

CHARACTERISTICS

- ◆ Available in four standard sizes with 120mm width (internal), 2,4,6,8. Multiple frames are available as combination of two or more apertures arranged horizontally, vertically or both combined.
- ◆ Designed to be welded onto a bulkhead or deck.
- ◆ Materials: Mild Steel, Stainless Steel.
Other materials under request.
- ◆ To be sealed with standard or EMC HF blocks, compression systems and accessories.

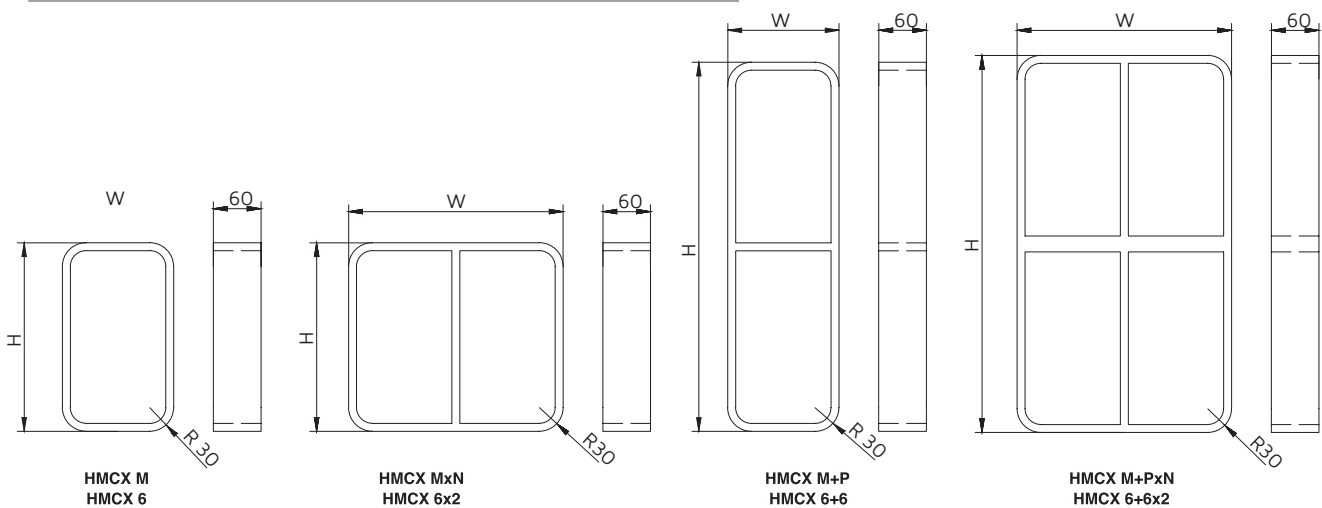

*Frame designation: M = size row 1; P = size row 2; N = number of columns.

DESCRIPTION	EXTERNAL DIMENSIONS (mm)		WEIGHT (Kg)	
	W	H	Mild Steel	Stainless Steel
HMCX R30 4	140	179,5	2,6	2,7
HMCX R30 4x2	271	179,5	4,6	4,7
HMCX R30 4x3	401	179,5	6,6	6,7
HMCX R30 4x4	531	179,5	8,5	8,7
HMCX R30 4x5	662	179,5	10,5	10,8
HMCX R30 4x6	792	179,5	12,5	12,8
HMCX R30 4+4	140	349	4,8	4,9
HMCX R30 4+4x2	271	359	9,4	9,6
HMCX R30 4+4x3	401	359	13,3	13,6
HMCX R30 4+4x4	531	359	17,3	17,7
HMCX R30 4+4x5	662	359	21,2	21,7
HMCX R30 4+4x6	792	359	25,1	25,8

*All dimensions are nominal values

HMCX Frame

DESCRIPTION	EXTERNAL DIMENSIONS (mm)		WEIGHT (Kg)	
	W	H	Mild Steel	Stainless Steel
HMCX R30 6	140	238	3,2	3,2
HMCX R30 6x2	271	238	5,5	5,6
HMCX R30 6x3	401	238	7,9	8,1
HMCX R30 6x4	531	238	10,2	10,5
HMCX R30 6x5	662	238	12,6	12,9
HMCX R30 6x6	792	238	14,9	15,3
HMCX R30 6+6	140	466	5,9	6,0
HMCX R30 6+6x2	271	476	11,0	11,3
HMCX R30 6+6x3	401	476	15,5	15,9
HMCX R30 6+6x4	531	476	20,0	20,5
HMCX R30 6+6x5	662	476	24,5	25,1
HMCX R30 6+6x6	792	476	29,0	29,7
HMCX R30 8	140	296,5	3,7	3,8
HMCX R30 8x2	271	296,5	6,2	6,4
HMCX R30 8x3	401	296,5	8,8	9,0
HMCX R30 8x4	531	296,5	11,3	11,6
HMCX R30 8x5	662	296,5	13,8	14,1
HMCX R30 8x6	792	296,5	16,3	16,7
HMCX R30 8+8	140	583	7,0	7,1
HMCX R30 8+8x2	271	593	12,7	13,0
HMCX R30 8+8x3	401	593	17,7	18,2
HMCX R30 8+8x4	531	593	22,8	23,3
HMCX R30 8+8x5	662	593	27,8	28,5
HMCX R30 8+8x6	792	593	32,8	33,7

*For other sizes or frame combinations not presented here, contact sales department

*All dimensions are nominal values

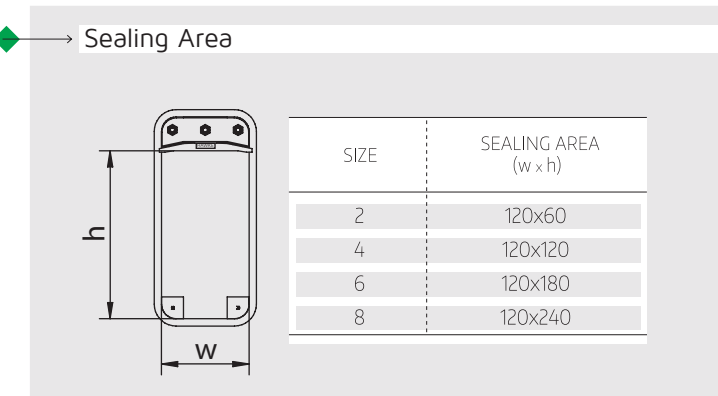

Installation references

	page
See assembly parts	66
See accessories	76
See installation guide	118
See welding instructions	150
See inspection check	158

HMRX TB Frame

Standard HMX frame with end fillet pieces with radius corners added to the top and bottom sides of the frame for high stressed area applications.

CHARACTERISTICS

- ◆ Available in four standard sizes with 120mm width (internal), 2,4,6,8. Multiple frames are available as combination of two or more apertures arranged horizontally, vertically or both combined.
- ◆ Designed to be welded to a bulkhead or deck.
- ◆ Materials: Mild Steel, Stainless Steel.
Other materials under request.
- ◆ To be sealed with standard or EMC HF blocks, compression systems and accessories.

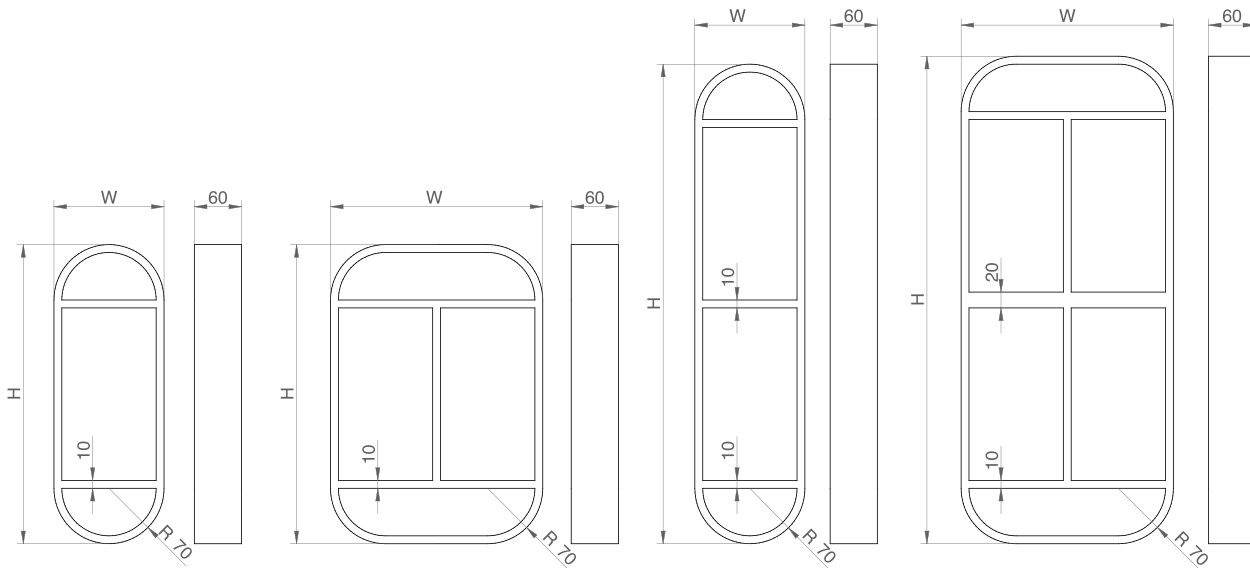

HMRX TB M
HMRX TB 6

HMRX TB MxN
HMRX TB 6x2

HMRX TB M+P
HMRX TB 6+6

HMRX TB M+PxN
HMRX TB 6+6x2

*Frame designation: M = size row 1; P = size row 2; N = number of columns.

TYPE	EXTERNAL DIMENSIONS (mm)		WEIGHT (Kg)	
	W	H	Mild Steel	Stainless Steel
HMRX R70 TB 2	140	261	5,1	5,2
HMRX R70 TB 4	140	319,5	5,6	5,8
HMRX R70 TB 6	140	378	6,2	6,3
HMRX R70 TB 6x2	271	378	10,9	11,1
HMRX R70 TB 6x3	401	378	15,6	15,9
HMRX R70 TB 6x4	531	378	20,2	20,7
HMRX R70 TB 6x5	662	378	24,9	25,5
HMRX R70 TB 6x6	792	378	29,6	30,4

*For other sizes or frame combinations not presented here, contact sales department

*All dimensions are nominal values

HMRX TB Frame

TYPE	EXTERNAL DIMENSIONS (mm)		WEIGHT (Kg)	
	W	H	Mild Steel	Stainless Steel
HMRX R70 TB 6+6	140	606	8,9	9,1
HMRX R70 TB 6+6x2	271	616	16,5	16,9
HMRX R70 TB 6+6x3	401	616	23,4	24,0
HMRX R70 TB 6+6x4	531	616	30,3	31,1
HMRX R70 TB 6+6x5	662	616	37,3	38,2
HMRX R70 TB 6+6x6	792	616	44,2	45,3
HMRX R70 TB 8	140	436,5	6,7	6,9
HMRX R70 TB 8x2	271	436,5	11,7	12,0
HMRX R70 TB 8x3	401	436,5	16,7	17,1
HMRX R70 TB 8x4	531	436,5	21,6	22,2
HMRX R70 TB 8x5	662	436,5	26,6	27,2
HMRX R70 TB 8x6	792	436,5	31,5	32,3
HMRX R70 TB 8+8	140	723	10,0	10,2
HMRX R70 TB 8+8x2	271	733	18,1	18,6
HMRX R70 TB 8+8x3	401	733	25,6	26,2
HMRX R70 TB 8+8x4	531	733	33,1	33,9
HMRX R70 TB 8+8x5	662	733	40,6	41,6
HMRX R70 TB 8+8x6	792	733	48,1	49,3

*For other sizes or frame combinations not presented here, contact sales department

*All dimensions are nominal values

→ Sealing Area

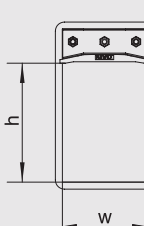

SIZE	SEALING AREA (w x h)
2	120x60
4	120x120
6	120x180
8	120x240

→ Installation references

	page
See assembly parts	66
See accessories	76
See installation guide	116
See welding instructions	150
See inspection check	158

DIMENSIONS

Guidelines $\blacklozenge \rightarrow$ for marine frames.

$\blacklozenge \rightarrow$ HMX/HMOX/HMCX

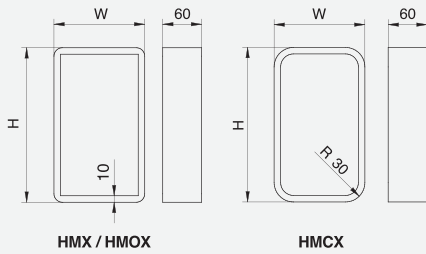

$$\begin{aligned} W &= W_i \\ H &= H_i \end{aligned}$$

$\blacklozenge \rightarrow$ HMFx/HMFBx

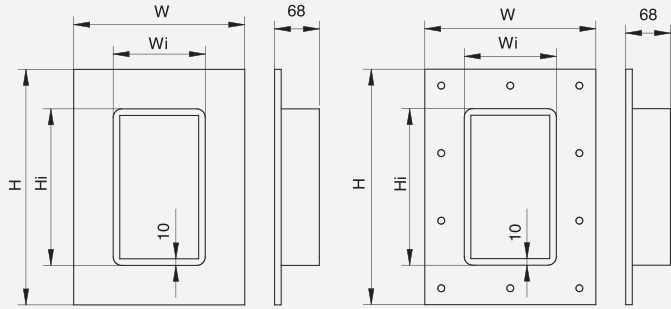

$$\begin{aligned} W &= W_i + 120 \\ H &= H_i + 120 \end{aligned}$$

$\blacklozenge \rightarrow$ HMRx TB

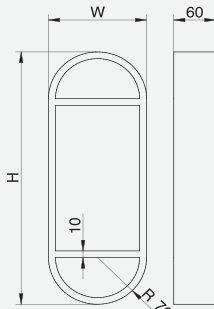

$$\begin{aligned} W &= W_i \\ H &= H_i + 140 \end{aligned}$$

$\blacklozenge \rightarrow$ HMEx/HMBx

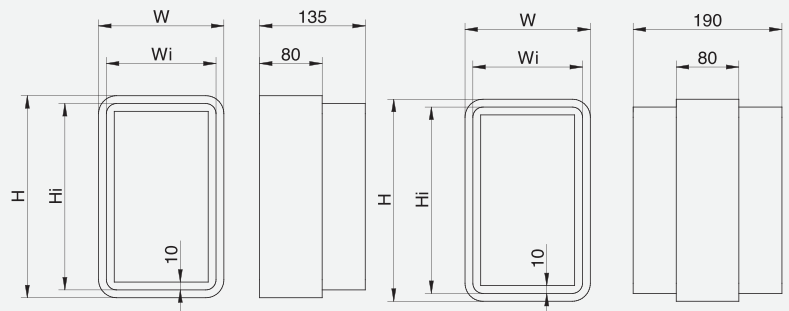

$$\begin{aligned} W &= W_i + 20 \\ H &= H_i + 20 \end{aligned}$$

Size	x 1		Hi (mm)	x N										
	Hi (mm)	Wi (mm)		Wi (mm)										
				x 2	x 3	x 4	x 5	x 6	x 7	x 8	x 9	x 10		
2	121	140	121											
2+2	232	140	242											
4	179,5	140	179,5											
4+2	290,5	140	300,5											
4+4	349	140	359											
6	238	140	238											
6+2	349	140	359	271	401	531	662	792	922	1052	1183	1313		
6+4	407,5	140	417,5											
6+6	466	140	476											
8	296,5	140	296,5											
8+2	407,5	140	417,5											
8+4	466	140	476											
8+6	524,5	140	534,5											
8+8	583	140	593											

DRILLING

Guidelines  for marine frames.

 HMFBX

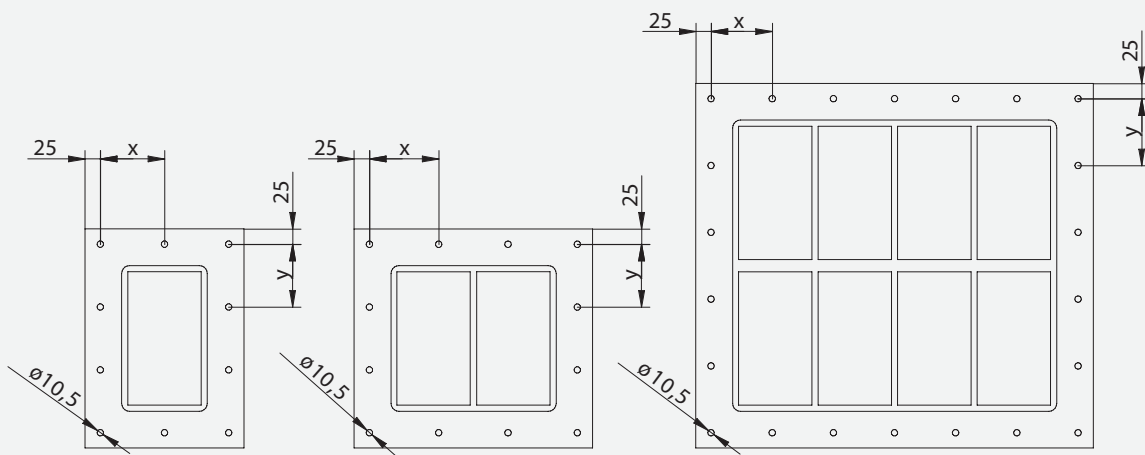

SIZE	x1		y (mm) & Ny	x N										Ø (mm)	
	y (mm) & Ny	x (mm) & Nx		x (mm) & Nx											
				x2	x3	x4	x5	x6	x7	x8	x9	x10			
2	96 (2)		96 (2)												10,5
2+2	101 (3)		104 (3)												10,5
4	83 (2)		83 (2)												10,5
4+2	90 (3)		93 (3)												10,5
4+4	105 (3)		107 (3)												10,5
6	103 (3)		103 (3)												10,5
6+2	105 (4)	105 (3)	107 (4)	113 (4)	94 (6)	100 (7)	91 (9)	96 (10)	99 (11)	102 (12)	104 (13)	106 (14)		10,5	
6+4	96 (4)		98 (4)											10,5	
6+6	107 (4)		109 (4)											10,5	
8	92 (3)		92 (3)												10,5
8+2	96 (4)		98 (4)											10,5	
8+4	107 (4)		109 (4)											10,5	
8+6	99 (5)		101 (5)											10,5	
8+8	109 (5)		111 (5)											10,5	

Nx: Number of horizontal holes; Ny: Number of vertical holes; ø: Diameter of holes (mm); N: number of columns



CIVIL FRAMES

CIVIL FRAMES

Frame with removable end which allows the frame to be installed around existing cables and pipes- **HCOX**



Civil large frame for sealing services with an overall diameter in excess of 100mm. - **HCLX**





Civil large frame with removable end which allows the frame to be installed around existing cable or pipe. - **HCLOX**



Standard Civil Flanged frame to be bolted or casted to a wall or floor. - **HCX**

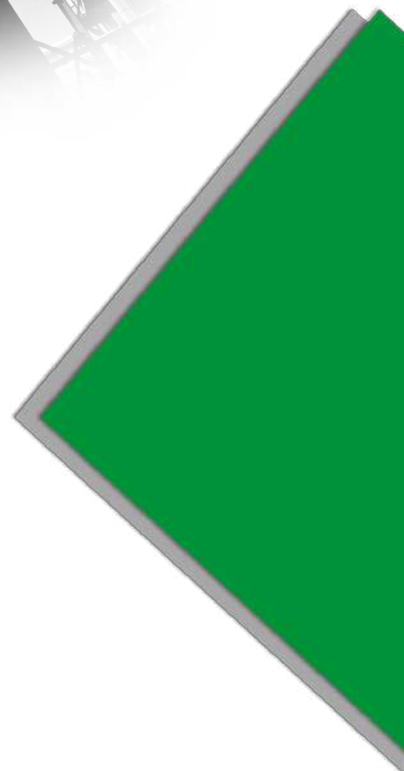

HCX Frame

Rectangular Civil Frame with flange. Made in 6mm thickness steel with 60mm flange.

CHARACTERISTICS

- ◆ Available in four standard sizes 120 width, 2,4,6,8 and in four standard sizes 60mm width, 1,3,5,7. Multiple frames are available as combination of two or more apertures arranged horizontally, vertically or both combined.
- ◆ Designed to be bolted or casted.
- ◆ Materials: Mild Steel, Stainless Steel.
Other materials under request.
- ◆ To be sealed with standard or EMC HF blocks, compression systems and accessories.

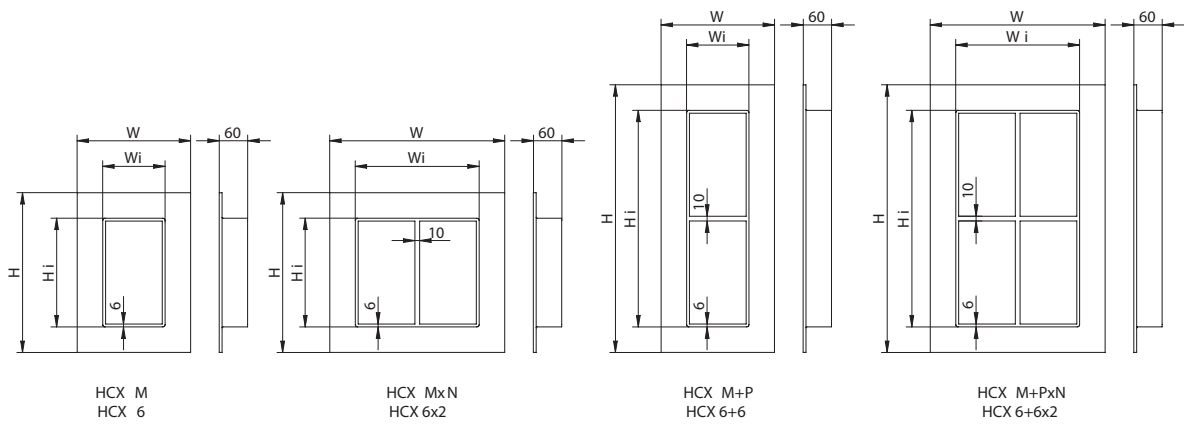

*Frame designation: M = size row 1; P = size row 2; N = number of columns.

DESCRIPTION	EXTERNAL DIMENSIONS (mm)				WEIGHT (Kg)	
	W	H	Wi	Hi	Mild Steel	Stainless Steel
HCX 2	240	221	132	113	3,1	3,2
HCX 2x2	371	221	263	113	5,0	5,1
HCX 2x3	501	221	393	113	6,8	7,0
HCX 2x4	631	221	523	113	8,7	8,9
HCX 2x5	762	221	654	113	10,6	10,9
HCX 2x6	892	221	784	113	12,4	12,8
HCX 4	240	280	132	171,5	3,7	3,8
HCX 4x2	371	280	263	171,5	5,9	6,0
HCX 4x3	501	280	393	171,5	8,0	8,2
HCX 4x4	631	280	523	171,5	10,2	10,5
HCX 4x5	762	280	654	171,5	12,3	12,6
HCX 4x6	892	280	784	171,5	14,5	14,8

*All dimensions are nominal values

HCX Frame

DESCRIPTION	EXTERNAL DIMENSIONS (mm)				WEIGHT (Kg)	
	W	H	Wi	Hi	Mild Steel	Stainless Steel
HCX 4+4	240	449	132	341	6,1	6,3
HCX 4+4x2	371	449	263	341	9,6	9,8
HCX 4+4x3	501	449	393	341	13,1	13,4
HCX 4+4x4	631	449	523	341	16,6	17,0
HCX 4+4x5	762	449	654	341	20,1	20,6
HCX 4+4x6	892	449	784	341	23,6	24,2
HCX 6	240	338	132	230	4,4	4,5
HCX 6x2	371	338	263	230	6,8	7,0
HCX 6x3	501	338	393	230	9,2	9,4
HCX 6x4	631	338	523	230	11,6	11,9
HCX 6x5	762	338	654	230	14,0	14,3
HCX 6x6	892	338	784	230	16,5	16,9
HCX 6+6	240	566	132	458	7,4	7,6
HCX 6+6x2	371	566	263	458	11,4	11,7
HCX 6+6x3	501	566	393	458	15,5	15,9
HCX 6+6x4	631	566	523	458	19,5	20,0
HCX 6+6x5	762	566	654	458	23,6	24,2
HCX 6+6x6	892	566	784	458	27,6	28,3
HCX 8	240	397	132	288,5	5,0	5,1
HCX 8x2	371	397	263	288,5	7,7	7,9
HCX 8x3	501	397	393	288,5	10,4	10,7
HCX 8x4	631	397	523	288,5	13,1	13,4
HCX 8x5	762	397	654	288,5	15,8	16,2
HCX 8x6	892	397	784	288,5	18,5	18,9
HCX 8+8	240	683	132	575	8,6	8,8
HCX 8+8x2	371	683	263	575	13,2	13,5
HCX 8+8x3	501	683	393	575	17,8	18,2
HCX 8+8x4	631	683	523	575	22,4	23,0
HCX 8+8x5	762	683	654	575	27,0	27,7
HCX 8+8x6	892	683	784	575	31,6	32,4

*For other sizes or frame combinations not presented here, contact sales department

*All dimensions are nominal values

→ Sealing Area

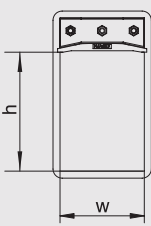

SIZE	SEALING AREA (w x h)
2	120x60
4	120x120
6	120x180
8	120x240

→ Installation references

	page
See assembly parts	66
See accessories	76
See installation guide	116
See bolted instructions	141
See inspection check	158

HCOX Frame

Rectangular civil frame with 60mm flange and removable end which allows installation around existing cables. Made in 6mm thickness steel with 60mm flange.

CHARACTERISTICS

- ◆ Available in four standard sizes 120 width, 2,4,6,8. Multiple frames are available as combination of two or more apertures arranged horizontally, vertically or both combined.
- ◆ Designed to be bolted or casted.
- ◆ Materials: Mild Steel, Stainless Steel.
Other materials under request.
- ◆ To be sealed with standard or EMC HF blocks, compression systems and accessories.

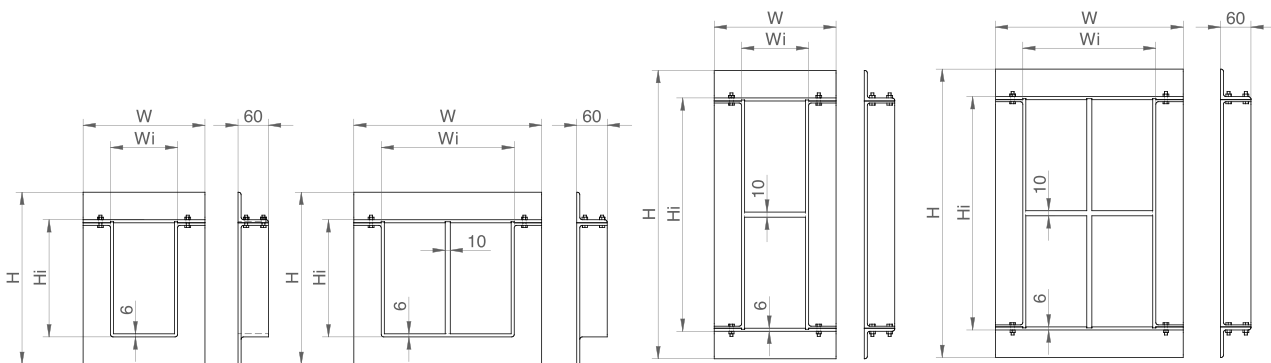

HCOX M
HCOX 6

HCOX MxN
HCOX 6x2

HCOX M+P
HCOX 6+6

HCOX M+PxN
HCOX 6+6x2

*Frame designation: M = size row 1; P = size row 2; N = number of columns.

DESCRIPTION	EXTERNAL DIMENSIONS (mm)				WEIGHT (Kg)	
	W	H	Wi	Hi	Mild Steel	Stainless Steel
HCOX 2	240	221	132	113	3,6	3,7
HCOX 2x2	371	221	263	113	5,5	5,6
HCOX 2x3	501	221	393	113	7,3	7,5
HCOX 2x4	631	221	523	113	9,1	9,3
HCOX 2x5	762	221	654	113	10,9	11,2
HCOX 2x6	892	221	784	113	12,7	13,1
HCOX 4	240	280	132	172	4,3	4,4
HCOX 4x2	371	280	263	172	6,3	6,5
HCOX 4x3	501	280	393	172	8,4	8,6
HCOX 4x4	631	280	523	172	10,5	10,7
HCOX 4x5	762	280	654	172	12,5	12,9
HCOX 4x6	892	280	784	172	14,6	15,0

*All dimensions are nominal values

HCOX Frame

DESCRIPTION	EXTERNAL DIMENSIONS (mm)				WEIGHT (Kg)	
	W	H	Wi	Hi	Mild Steel	Stainless Steel
HCOX 4+4	240	449	132	341	7,0	7,2
HCOX 4+4x2	371	449	263	341	10,3	10,6
HCOX 4+4x3	501	449	393	341	13,6	13,9
HCOX 4+4x4	631	449	523	341	16,9	17,3
HCOX 4+4x5	762	449	654	341	20,2	20,7
HCOX 4+4x6	892	449	784	341	23,4	24,0
HCOX 6	240	338	132	230	4,9	5,0
HCOX 6x2	371	338	263	230	7,2	7,4
HCOX 6x3	501	338	393	230	9,5	9,8
HCOX 6x4	631	338	523	230	11,8	12,1
HCOX 6x5	762	338	654	230	14,2	14,5
HCOX 6x6	892	338	784	230	16,5	16,9
HCOX 6+6	240	566	132	458	8,3	8,5
HCOX 6+6x2	371	566	263	458	12,1	12,4
HCOX 6+6x3	501	566	393	458	15,9	16,3
HCOX 6+6x4	631	566	523	458	19,6	20,1
HCOX 6+6x5	762	566	654	458	23,4	24,0
HCOX 6+6x6	892	566	784	458	27,2	27,9
HCOX 8	240	397	132	289	5,5	5,7
HCOX 8x2	371	397	263	289	8,1	8,3
HCOX 8x3	501	397	393	289	10,7	10,9
HCOX 8x4	631	397	523	289	13,2	13,5
HCOX 8x5	762	397	654	289	15,8	16,2
HCOX 8x6	892	397	784	289	18,3	18,8
HCOX 8+8	240	683	132	575	9,6	9,8
HCOX 8+8x2	371	683	263	575	13,8	14,2
HCOX 8+8x3	501	683	393	575	18,1	18,6
HCOX 8+8x4	631	683	523	575	22,4	22,9
HCOX 8+8x5	762	683	654	575	26,7	27,3
HCOX 8+8x6	892	683	784	575	30,9	31,7

*For other sizes or frame combinations not presented here, contact sales department

*All dimensions are nominal values

→ Sealing Area

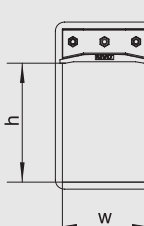

SIZE	SEALING AREA (w x h)
2	120x60
4	120x120
6	120x180
8	120x240

→ Installation references

	page
See assembly parts	66
See accessories	76
See installation guide	116
See bolted instructions	141
See inspection check	158

HCLX Frame

Rectangular civil frame with 60mm flange for sealing services with an overall diameter greater than 100mm. Made in 6mm thickness steel.

CHARACTERISTICS

- ◆ Available in three standard sizes: 180, 240 and 360.
- ◆ Designed to be bolted or casted into a wall or structure.
- ◆ Materials: Mild Steel, Stainless Steel.
Other materials under request.
- ◆ To be sealed using standard or EMC HF blocks.
- ◆ To be sealed using special compression system (180, 240 or 360mm).

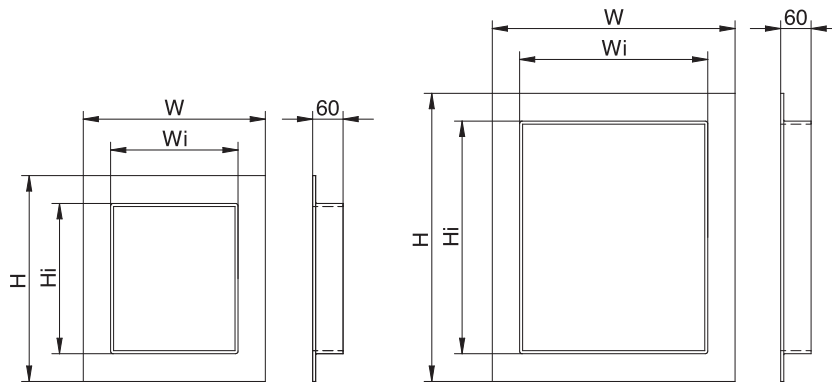

DESCRIPTION	EXTERNAL DIMENSIONS (mm)				WEIGHT (Kg)	
	W	H	Wi	Hi	Mild Steel	Stainless Steel
HCLX 180	300	338	192	230	5,0	5,1
HCLX 240	360	400	252	292	6,3	6,5
HCLX 360	480	560	372	452	9,3	9,5

*All dimensions are nominal values

◆ → Sealing Area

SIZE	SEALING AREA (w x h)
180	180 x 180
240	240 x 240
360	360 x 360

◆ → Installation references

	page
See assembly parts	66
See accessories	76
See installation guide	116
See bolted instructions	141
See inspection check	158

HCLOX Frame

Rectangular civil frame with 60mm flange for sealing services with an overall diameter greater than 100mm. Made in 6mm thickness steel. It has a removable end for retrofitting around an existing cable or pipe.



CHARACTERISTICS

- ◆ Available in three standard sizes: 180, 240 and 360.
- ◆ Designed to be bolted or casted into a wall or structure.
- ◆ Materials: Mild Steel, Stainless Steel.
Other materials under request.
- ◆ To be sealed using standard or EMC HF blocks.
- ◆ To be sealed using special compression system (180, 240 or 360mm).

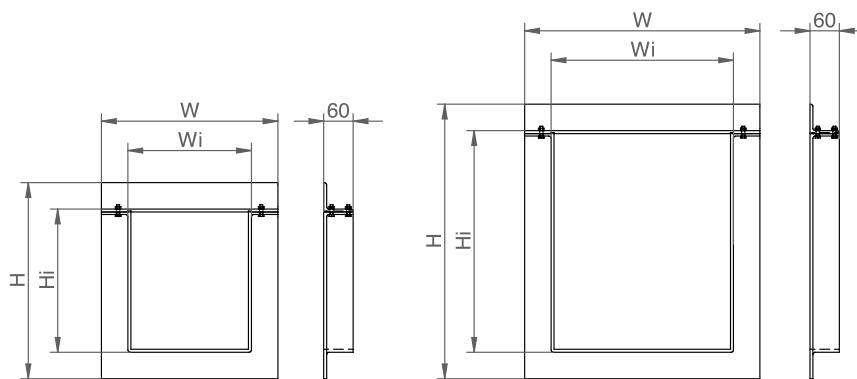

DESCRIPTION	EXTERNAL DIMENSIONS (mm)				WEIGHT (Kg)	
	W	H	Wi	Hi	Mild Steel	Stainless Steel
HCLOX 180	300	338	192	230	5,5	5,6
HCLOX 240	360	400	252	292	6,9	9,0
HCLOX 360	480	560	372	452	10,2	10,5

*All dimensions are nominal values

Sealing Area

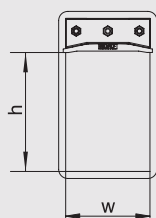

SIZE	SEALING AREA (w x h)
180	180 x 180
240	240 x 240
360	360 x 360

Installation references

	page
See assembly parts	66
See accessories	76
See installation guide	116
See bolted instructions	141
See inspection check	158

DIMENSIONS

Guidelines $\blacklozenge \rightarrow$ for civil frames.

$\blacklozenge \rightarrow$ HCX/HCOX

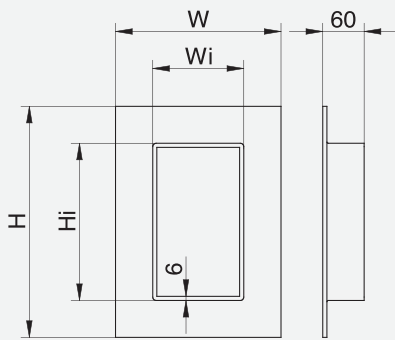

HCX

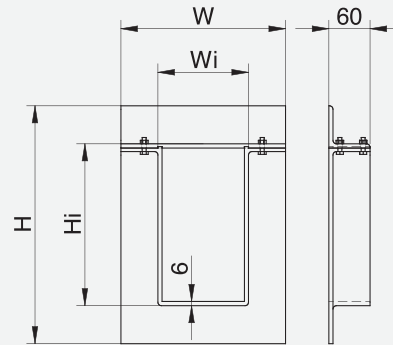

HCOX

$$W = W_i + 108$$

$$H = H_i + 108$$

SIZE	x 1		Hi (mm)	x N											
	Hi (mm)	Wi (mm)		Wi (mm)											
				x 2	x 3	x 4	x 5	x 6	x 7	x 8	x 9	x 10			
2	113	132	113												
2+2	224	132	224												
4	171,5	132	171,5												
4+2	282,5	132	282,5												
4+4	341	132	341												
6	230	132	230												
6+2	341	132	341	263	393	523	654	784	914	1044	1175	1305			
6+4	399,5	132	399,5												
6+6	458	132	458												
8	288,5	132	288,5												
8+2	399,5	132	399,5												
8+4	458	132	458												
8+6	516,5	132	516,5												
8+8	575	132	575												

DRILLING

Guidelines  for civil frames.

 HCX/HCOX

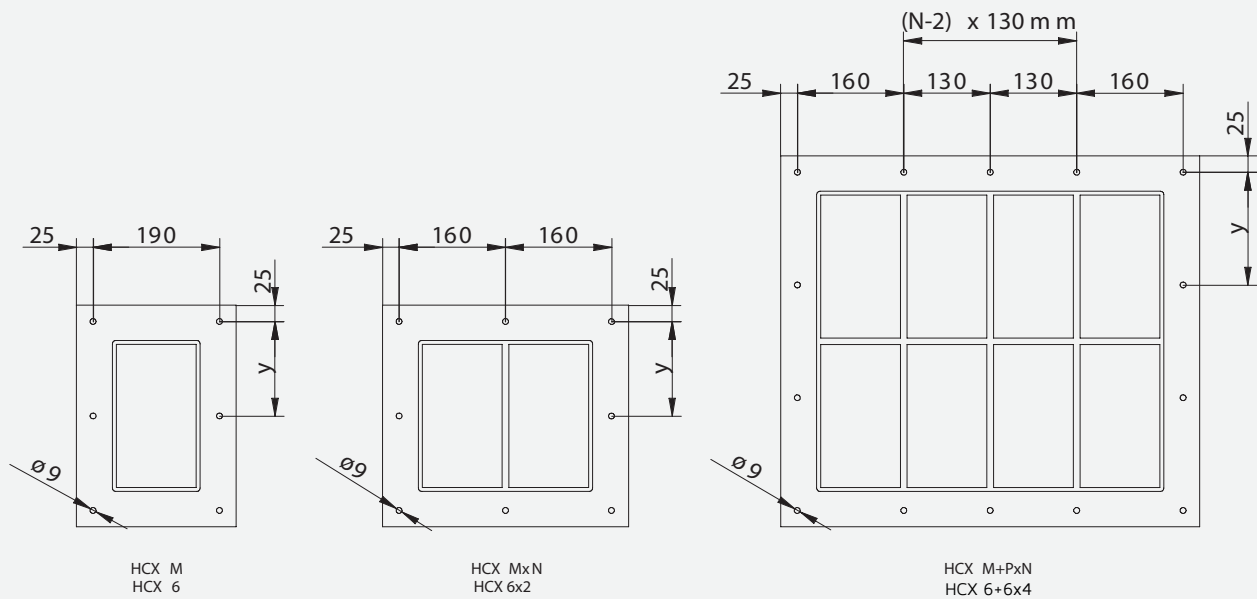

SIZE	NUMBER OF VERTICAL HOLES	y (mm)	NUMBER OF HORIZONTAL HOLES										
			x1	x2	x3	x4	x5	x6	x7	x8	x9	x10	
1*	2	171											
2	2	171											
2+2	3	141											
3*	2	229											
4	2	229											
4+2	3	170											
4+4	3	200											
5*	3	144											
6	3	144	2	3	4	5	6	7	8	9	10	11	
6+2	4	133											
6+4	4	152											
6+6	4	172											
7*	3	173											
8	3	173											
8+2	4	152											
8+4	4	172											
8+6	5	144											
8+8	5	158											

* 60 mm with frames (1, 3, 5, 7) only available for HCX civil frames in x1 aperture size.

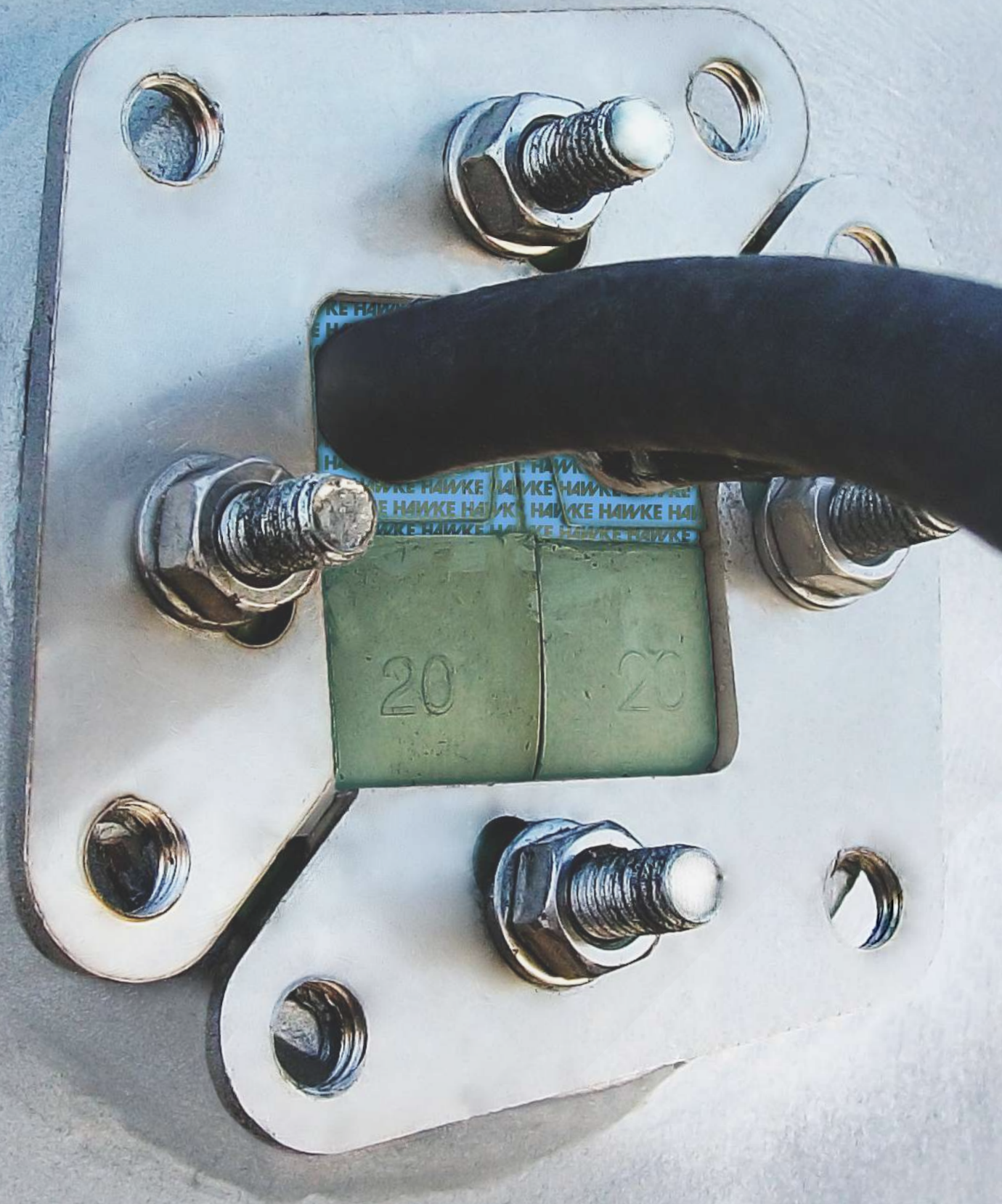

ROUND TRANSITS

HRTO Family

Hawke HRTO is a round sealing solution for multiple cables/pipes passing through a circular aperture in a wall or bulkhead/deck.

The seal is formed by tightening the compression bolts which expand the system radially with no need of a compression system.

CHARACTERISTICS

- ◆ Designed to be installed using Hawke Sleeves (welded, bolted or casted) and standard HF blocks.
- ◆ Manufactured in intumescent elastomer polymer with stainless steel front and back plates. Plates also available in mild steel.
- ◆ HRTO is always supplied as an open frame. This enables the frame to be installed after cable/pipe installation.
- ◆ No extra tools are required for its installation.

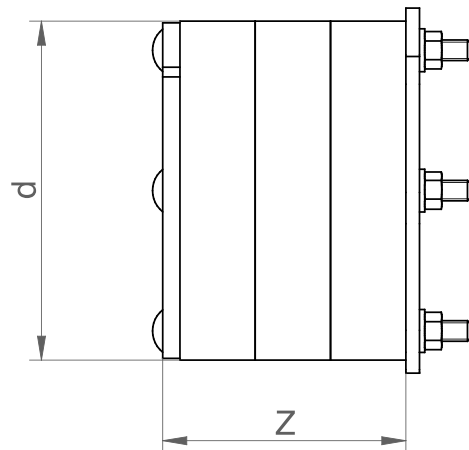
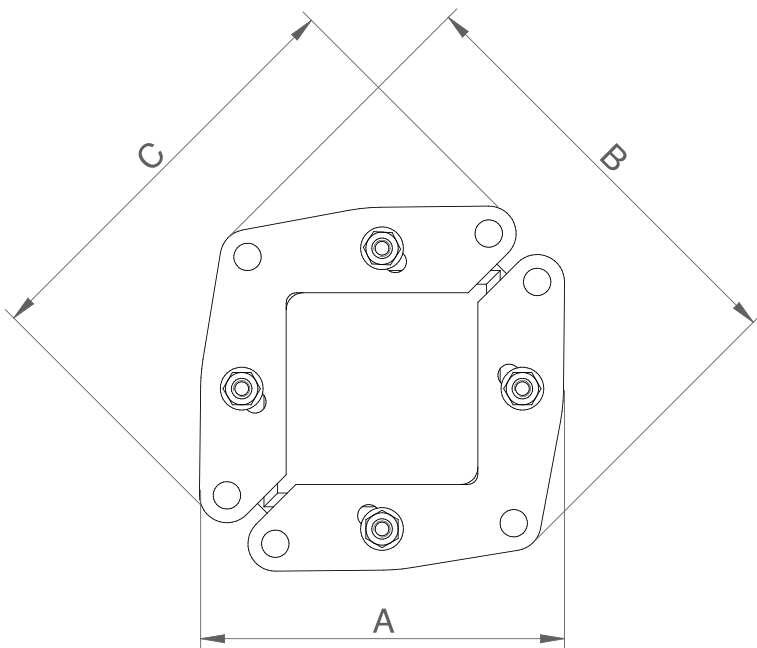
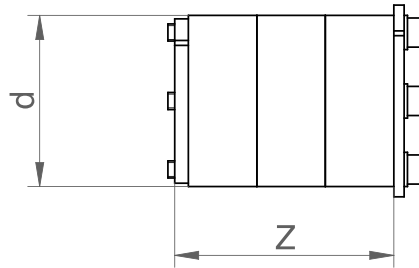
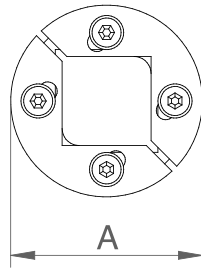

HRTO Family

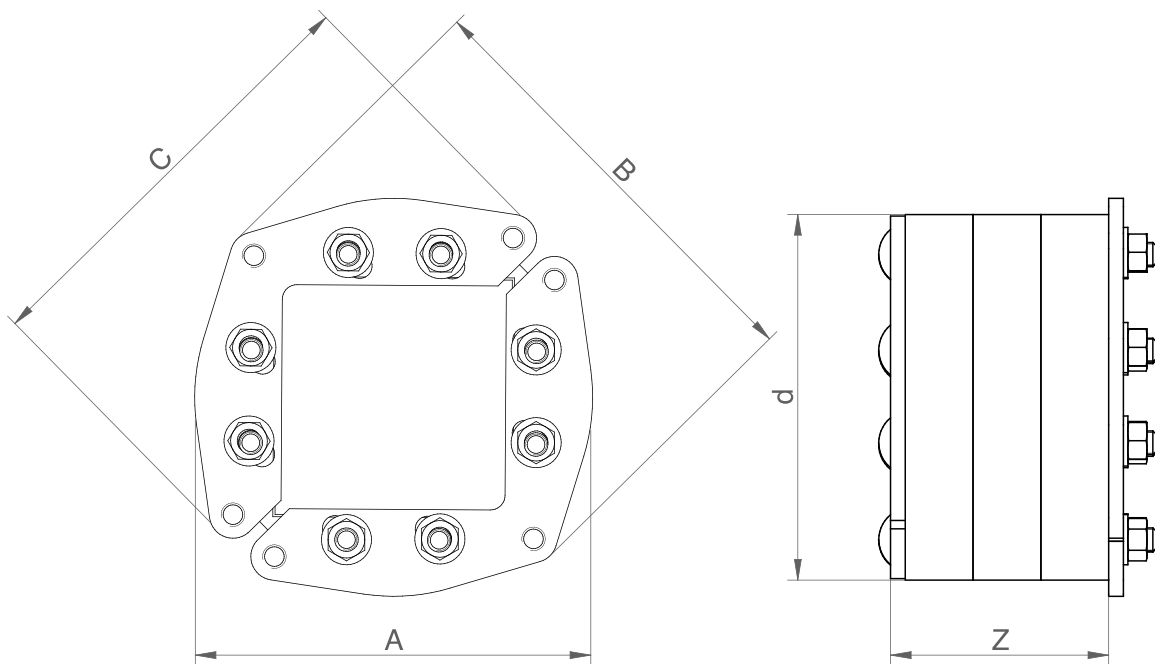

DESCRIPTION	SLEEVE SIZE NEEDED	A (mm)	B (mm)	C (mm)	d (mm)	Z (mm)	Weight (kg)
HRTO-30	30	36	-	-	32	64	0,11
HRTO-40	40	46	-	-	40	64	0,15
HRTO-50	50	56	-	-	50	64	0,2
HRTO-70	70	85	105	50	70	70	0,5
HRTO-100	100	108	137	94	100	70	0,8
HRTO-125	125	150	163	124	125	74	0,95
HRTO-150	150	160	187	179	150	74	1,9
HRTO-200	200	210	237	226	200	74	3,7

*All dimensions are nominal values

Sealing Area

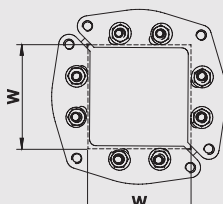

TYPE	SEALING AREA (mm)
HRTO-30	15x15
HRTO-40	20x20
HRTO-50	30x30
HRTO-70	40x40
HRTO-100	60x60
HRTO-125	80x80
HRTO-150	90x90
HRTO-200	120x120

Installation references

	page
See assembly parts	66
See accessories	76
See installation guide	120
See inspection check	160

HRST Family

Hawke HRST is a round sealing solution for a single cable/pipe passing through a wall or bulkhead/deck

Each size of HRST frame can seal a large range of diameters without any onsite modifications.

CHARACTERISTICS

- ◆ Available to seal services from 4mm up to 170mm of external diameter (standard version).
- ◆ Tolerant up to 7 mm.
- ◆ Designed to be installed using Hawke Sleeves (welded, bolted or casted).
- ◆ Manufactured in intumescent elastomer polymer with stainless steel front and back plates. Each HRST frame has a gasket to prevent galvanic corrosion when installed within a mild steel sleeve.
- ◆ HRST is always supplied as an open frame. This enables the frame to be installed after cable/pipe installation.
- ◆ No extra tools are required for its installation.

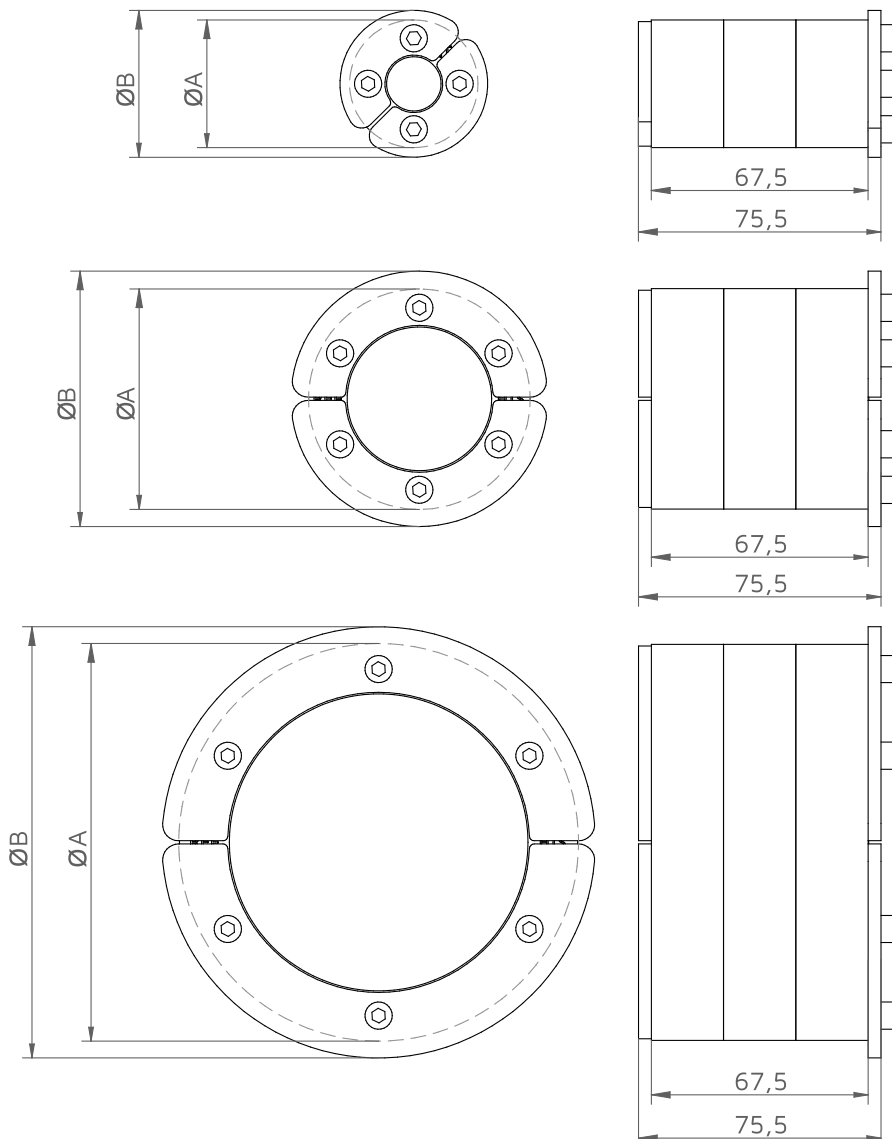
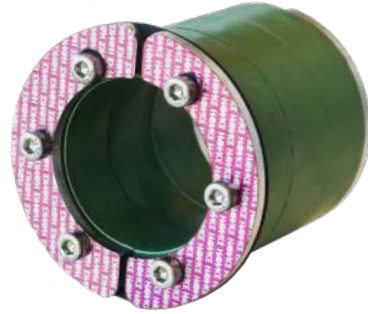

HRST Family

DESCRIPTION	SLEEVE SIZE NEEDED	SEALING FROM (mm)	SEALING TO (mm)	A (mm)	B (mm)	WEIGHT (kg)	COLOUR
HRST-30/4	30	4	10	32	36	0,16	White
HRST-30/7	30	7	14	32	36	0,15	Red
HRST-30/10	30	10	17	32	36	0,14	Blue
HRST-40/4	40	4	10	40	46	0,24	Purple
HRST-40/7	40	7	14	40	46	0,23	yellow
HRST-40/10	40	10	17	40	46	0,21	Green
HRST-40/17	40	17	24	40	46	0,18	Pink
HRST-50/4	50	4	10	50	56	0,35	Red
HRST-50/10	50	10	17	50	56	0,33	White
HRST-50/17	50	17	24	50	56	0,29	Blue
HRST-50/24	50	24	30	50	56	0,25	Orange
HRST-70/26	70	26	33	69	80	0,56	Purple
HRST-70/33	70	33	39	69	80	0,50	Yellow
HRST-70/39	70	39	45	69	80	0,44	Green
HRST-70/45	70	45	50	69	80	0,38	Pink
HRST-100/48	100	48	55	99	110	0,96	Red
HRST-100/55	100	55	61	99	110	0,87	White
HRST-100/61	100	61	66	99	110	0,79	Blue
HRST-100/66	100	66	71	99	110	0,71	Orange
HRST-125/64	125	64	71	124	135	1,42	Purple
HRST-125/71	125	71	79	124	135	1,27	Yellow
HRST-125/79	125	79	86	124	135	1,12	Green
HRST-125/86	125	86	93	124	135	0,96	Pink
HRST-125/93	125	93	98	124	135	0,84	Orange
HRST-150/93	150	93	102	149	160	1,79	Red
HRST-150/102	150	102	108	149	160	1,63	White
HRST-150/108	150	108	115	149	160	1,43	Blue
HRST-150/115	150	115	120	149	160	1,28	Orange
HRST-175/118	175	118	125	174	185	2,16	Purple
HRST-175/125	175	125	132	174	185	1,93	Yellow
HRST-175/132	175	132	138	174	185	1,72	Green
HRST-175/138	175	138	145	174	185	1,47	Pink
HRST-200/136	200	136	143	199	210	2,73	Red
HRST-200/143	200	143	150	199	210	2,48	White
HRST-200/150	200	150	157	199	210	2,20	Blue
HRST-200/157	200	157	164	199	210	1,92	Orange
HRST-200/164	200	164	170	199	210	1,67	Yellow

*All dimensions are nominal values

Installation references

	page
See accessories	76
See installation guide	122
See inspection check	162

HRST 40 2D15

Hawke HRST multihole designed for the sealing of up to 2 cables with an external diameter between 10 and 15 mm.



- ◆ Empty cable space to be filled with Plug HRST 2D15

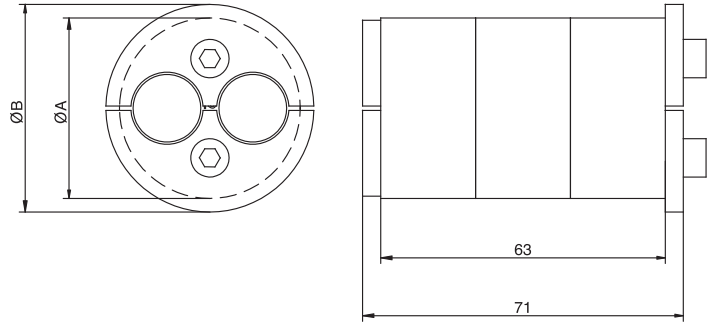

DESCRIPTION	SLEEVE SIZE NEEDED	NUMBER OF CABLES	SEALING FROM (mm)	SEALING TO (mm)	A (mm)	B (mm)	NUMBER OF BOLT	BOLT SIZE	WEIGHT (kg)
HRST 40 2D15	40	2	10	15	40	46	2	M5	0,17
Plug HRST 2D15				-					0,02

HRST 40 4D12

Hawke HRST multihole designed for the sealing of up to 4 cables with an external diameter between 8 and 12 mm.



- ◆ Empty cable space to be filled with Plug HRST 4D12

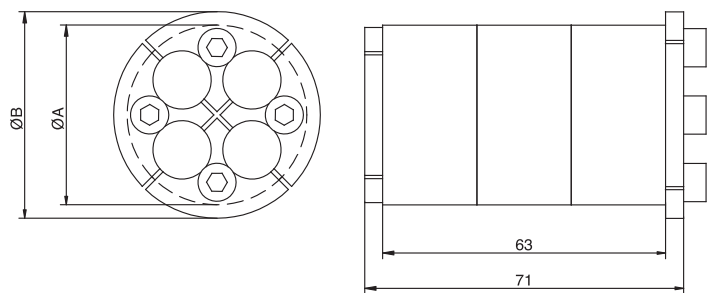

DESCRIPTION	SLEEVE SIZE NEEDED	NUMBER OF CABLES	SEALING FROM (mm)	SEALING TO (mm)	A (mm)	B (mm)	NUMBER OF BOLT	BOLT SIZE	WEIGHT (kg)
HRST 40 4D12	40	4	8	12	40	46	4	M5	0,16
Plug HRST 4D12				-					0,02

◆ → Installation references

	page
See accessories	76
See installation guide	124
See inspection check	163

SLEEVES

C Marine Sleeve

Sleeve without flange for Hawke Round transits.

CHARACTERISTICS

- ◆ Designed to be welded.
- ◆ Materials: Mild Steel, Stainless Steel and Aluminium
- ◆ To be sealed with standard or EMC HRT/HRTO and HRST.

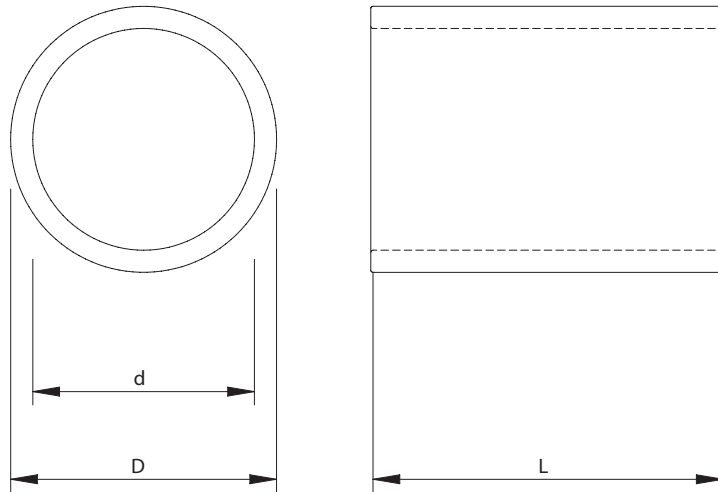

Mild Steel

DESCRIPTION	d (mm)	D (mm)	L (mm)	Weight (kg)
MSC -30 L=80	34	42	80	0,3
MSC -40 L=80	40	50	80	0,4
MSC -50 L=80	50	60	80	0,5
MSC -70 L=80	70	80	80	0,7
MSC -100 L=80	100	110	80	1,0
MSC -125 L=80	125	140	80	2,0
MSC -150 L=80	150	171	80	3,3
MSC -175 L=80	175	193,7	80	3,4
MSC -200 L=80	200	220	80	4,1

*All dimensions are nominal values

C Marine Sleeve

Stainless Steel

DESCRIPTION	d (mm)	D (mm)	L (mm)	Weight (kg)
SS C -30 L=80	33	42	80	0,3
SS C -40 L=80	40	50	80	0,4
SS C -50 L=80	50	60,3	80	0,6
SS C -70 L=80	70	88,9	80	1,5
SS C -100 L=80	100	114,3	80	1,5
SS C -125 L=80	125	141,3	80	2,2
SS C -150 L=80	150	168,3	80	2,9
SS C -175 L=80	175	194	80	-
SS C -200 L=80	200	220	80	4,2

*All dimensions are nominal values

Aluminium

DESCRIPTION	d (mm)	D (mm)	L (mm)	Weight (kg)
AL C -30 L=80	33	45	80	0,2
AL C -40 L=80	40	50	80	0,2
AL C -50 L=80	50	60	80	0,2
AL C -70 L=80	70	80	80	0,3
AL C -100 L=80	100	110	80	0,4
AL C -125 L=80	125	135	80	0,4
AL C -150 L=80	150	170	80	1,1
AL C -175 L=80	175	190	80	0,9
AL C -200 L=80	200	220	80	1,4

*All dimensions are nominal values

Installation references

	page
See assembly parts	66
See round frame HRTO	50
See round frame HRST	52
See accessories	76
See installation guide	116
See welding instructions	152
See inspection check	160

CB Sleeve

Sleeves with flange for Hawke Round transits.

CHARACTERISTICS

- ◆ Designed to be bolted or casted
- ◆ Materials: Mild Steel, Stainless Steel and Aluminium
- ◆ To be sealed with standard or EMC HRT/HRTO and HRST.

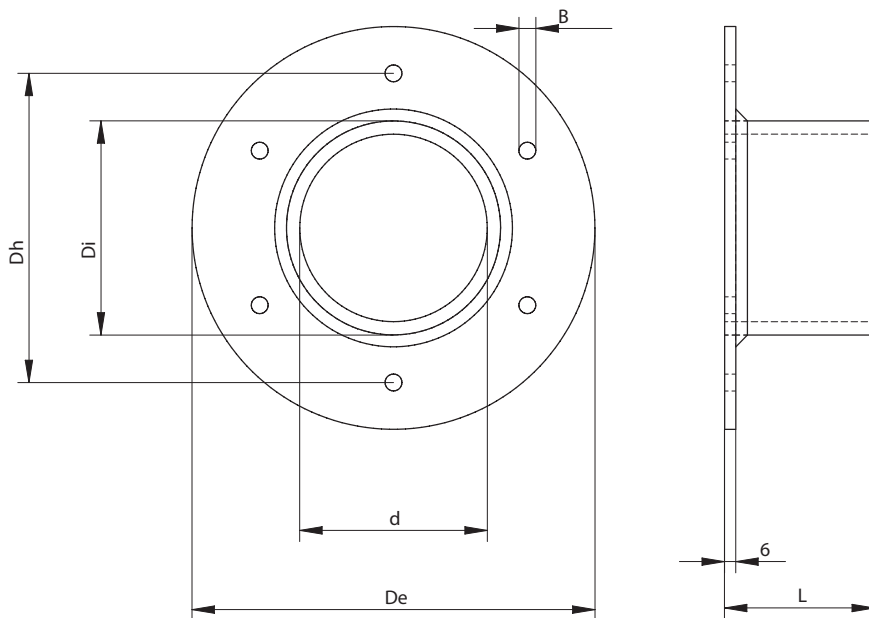

Mild Steel

DESCRIPTION	d (mm)	Di (mm)	De (mm)	Dh (mm)	L (mm)	B (mm)	Holes	Weight (kg)
MS CB-30	30	42	90	70	80	9	4	0,6
MS CB-40	40	50	100	80	80	9	4	0,7
MS CB-50	50	60	110	90	80	9	4	0,8
MS CB-70	70	80	130	110	80	9	4	1,3
MS CB-100	100	110	215	165	80	9	6	2,8
MS CB-125	125	140	240	190	80	9	6	3,4
MS CB-150	150	171	270	220	80	11	6	4,8
MS CB-175	175	194	-	-	80	-	-	-
MS CB-200	200	220	320	270	80	11	6	6,2

*All dimensions are nominal values

CB Sleeve

Stainless Steel

DESCRIPTION	d (mm)	Di (mm)	De (mm)	Dh (mm)	L (mm)	B (mm)	Holes	Weight (kg)
SS CB-30	34	42	90	70	80	9	4	0,6
SS CB-40	40	50	100	80	80	9	4	0,7
SS CB-50	50	60	110	90	80	9	4	0,9
SS CB-70	70	89	130	110	80	9	4	1,3
SS CB-100	100	114	215	165	80	9	6	2,9
SS CB-125	125	141	240	190	80	9	6	3,5
SS CB-150	150	168	270	220	80	11	6	5,0
SS CB-175	175	-	-	-	80	-	-	-
SS CB-200	200	220	320	270	80	11	6	6,3

*All dimensions are nominal values

◆ → Installation references

	page
See assembly parts	66
See round frame HRTO	50
See round frame HRST	52
See accessories	76
See installation guide	116
See bolted instructions	146
See inspection check	160

CBO Sleeve

Sleeve with flange and removable end which allows installation around existing cables. To be used with Hawke Round transits.

CHARACTERISTICS

- ◆ Designed to be bolted or casted
- ◆ Materials: Mild Steel, Stainless Steel and Aluminium
- ◆ To be sealed with standard or EMC HRT/HRTO and HRST.

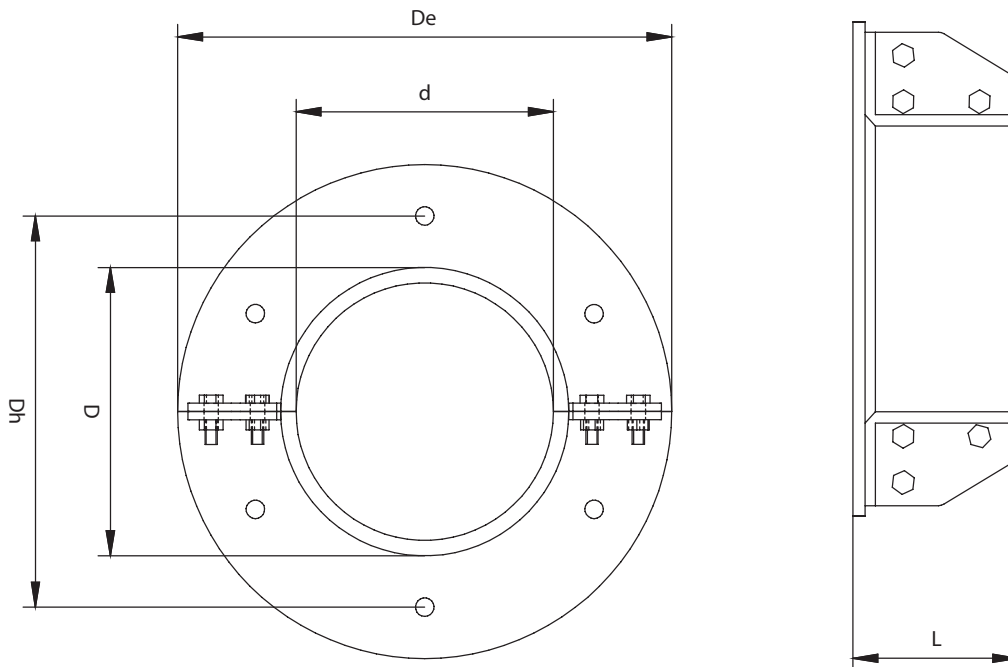

Mild Steel

DESCRIPTION	d (mm)	D (mm)	De (mm)	Dh (mm)	L (mm)	B (mm)	Holes	Weight (kg)
MS CBO-30	30	42	90	70	80	9	4	0,8
MS CBO-40	40	51	100	80	80	9	4	0,9
MS CBO-50	50	60,3	110	90	80	9	4	1,0
MS CBO-70	70	82,5	130	110	80	9	4	1,5
MS CBO-100	100	114,3	215	165	80	9	6	3,1
MS CBO-125	125	140	240	190	80	9	6	3,7
MS CBO-150	150	171	270	220	80	11	6	5,1
MS CBO-175	175	-	-	-	80	-	-	-
MS CBO-200	200	219,1	320	270	80	11	6	6,4

*All dimensions are nominal values

CBO Sleeve

Stainless Steel

DESCRIPTION	d (mm)	D (mm)	De (mm)	Dh (mm)	L (mm)	B (mm)	Holes	Weight (kg)
SS CBO-30	30	42,2	90	70	80	9	4	0,8
SS CBO-40	40	50	100	80	80	9	4	0,9
SS CBO-50	50	60,3	110	90	80	9	4	1,1
SS CBO-70	70	88,9	135	110	80	9	4	1,5
SS CBO-100	100	114,3	215	165	80	9	6	3,1
SS CBO-125	125	140	240	190	80	9	6	3,8
SS CBO-150	150	168,3	270	220	80	11	6	5,2
SS CBO-175	175	-	-	-	80	-	-	-
SS CBO-200	200	219,1	320	270	80	11	6	6,6

*All dimensions are nominal values

◆ → Installation references

	page
See assembly parts	66
See round frame HRTO	50
See round frame HRST	52
See accessories	76
See installation guide	116
See bolted instructions	146
See inspection check	160

CBC Sleeve

Sleeve with flange for Hawke Round transits.

CHARACTERISTICS

- ◆ Designed to be casted.
- ◆ Materials: Mild Steel, Stainless Steel and Aluminium.
- ◆ To be sealed with standard or EMC HRT/HRTO and HRST.

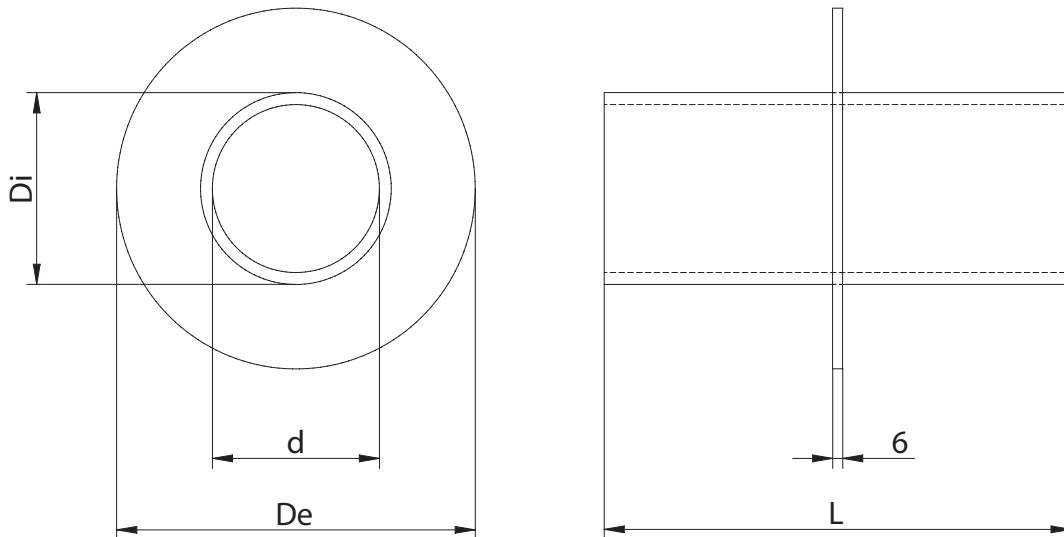

Mild Steel

DESCRIPTION	d (mm)	Di(mm)	De (mm)	L (mm)	Min.Weight (kg)
MS CBC-30	30	42	90	min 80	0,6
MS CBC-40	40	50	100	min 80	0,7
MS CBC-50	50	60	110	min 80	0,8
MS CBC-70	70	80	130	min 80	1,3
MS CBC-100	100	110	215	min 80	2,8
MS CBC-125	125	140	240	min 80	3,4
MS CBC-150	150	171	270	min 80	4,8
MS CBC-175	175	194	-	min 80	-
MS CBC-200	200	220	320	min 80	6,2

*All dimensions are nominal values

*Lenght (L) on demand in purchase order, minimum 80mm

**Weight indicated for minimum lenght of 80mm

CBC Sleeve

Stainless Steel

DESCRIPTION	d (mm)	Di(mm)	De (mm)	L (mm)	Min.Weight (kg)
SS CBC-30	34	42	90	min 80	0,6
SS CBC-40	40	50	100	min 80	0,7
SS CBC-50	50	60	110	min 80	0,9
SS CBC-70	70	89	130	min 80	1,3
SS CBC-100	100	114	215	min 80	2,9
SS CBC-125	125	141	240	min 80	3,5
SS CBC-150	150	168	270	min 80	5,0
SS CBC-175	175	-	-	min 80	-
SS CBC-200	200	220	320	min 80	6,3

*All dimensions are nominal values

*Lenght (L) on demand in purchase order, minimum 80mm

**Weight indicated for minimum lenght of 80mm

→ Installation references

	page
See assembly parts	66
See round frame HRTO	50
See round frame HRST	52
See accessories	76
See installation guide	116
See casted instructions	146
See inspection check	160



ASSEMBLY PARTS

TOLERANT BLOCKS

Hawke HF tolerant blocks are designed to accommodate cables/pipes passing through the frame. Our special design incorporates five contact points which allows the blocks to accommodate a range of different diameters and accept variances in cable/pipe diameter. Each block that a sealing range of 3-4mm without the need for any onsite modifications.

Also, Hawke's unique inspectable colour code make installation easier, faster and allows a visual inspection of the transit when complete.



CHARACTERISTICS

- ◆ Made of zero halogen, intumescent elastomeric polymer.
- ◆ No modification of the block needed during installation. Zero waste material.
- ◆ Four sealing grooves within the internal faces ensure correct contact all along the cable/pipe.
- ◆ Minimum and maximum sealing range is marked on the blocks. Also, the colour-coding allows for correct visual inspection. Our system can be visually inspected at a glance.

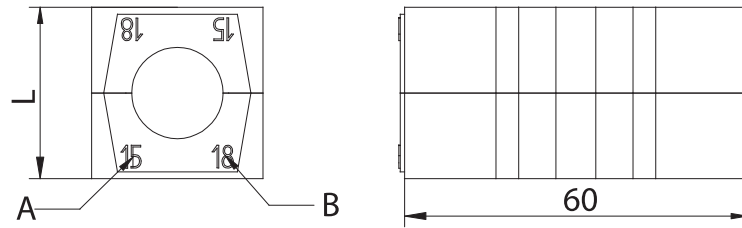

DESCRIPTION	L (mm)	CABLE AND PIPE DIAMETER		WEIGHT (kg)	COLOUR
		LABEL A MINIMUM (mm)	LABEL B MAXIMUM (mm)		
HF153	15	3	5	0,02	Red
HF155	15	5	7	0,02	White
HF157	15	7	9	0,01	Blue
HF203	20	3	6	0,03	Green
HF206	20	6	9	0,03	Pink
HF209	20	9	12	0,03	Brown
HF2011	20	11	14	0,02	Yellow
HF2013	20	13	16	0,02	Gold
HF3012	30	12	15	0,05	Red
HF3015	30	15	18	0,06	White
HF3018	30	18	21	0,05	Blue
HF3021	30	21	24	0,04	Orange
HF4012	40	12	15	0,12	Green
HF4015	40	15	18	0,12	Pink
HF4022	40	22	25	0,10	Red
HF4025	40	25	28	0,09	White
HF4028	40	28	31	0,08	Blue

◆→ TOLERANT BLOCKS

DESCRIPTION	L (mm)	CABLE AND PIPE DIAMETER		WEIGHT (kg)	COLOUR
		LABEL A	LABEL B		
		MINIMUM (mm)	MAXIMUM (mm)		
HF4031	40	31	34	0,07	Orange
HF6031	60	31	34	0,22	Red
HF6034	60	34	37	0,21	White
HF6037	60	37	40	0,20	Blue
HF6040	60	40	43	0,19	Orange
HF6043	60	43	46	0,18	Purple
HF6046	60	46	49	0,16	Yellow
HF6049	60	49	52	0,14	Green
HF6052	60	52	54	0,11	Pink
HF9053	90	53	56	0,46	Red
HF9056	90	56	59	0,44	White
HF9059	90	59	62	0,42	Blue
HF9062	90	62	65	0,40	Orange
HF9065	90	65	68	0,39	Purple
HF9068	90	68	71	0,36	Yellow
HF12072	120	72	75	0,79	Red
HF12075	120	75	78	0,75	White
HF12078	120	78	81	0,71	Blue
HF12081	120	81	84	0,67	Orange
HF12084	120	84	87	0,64	Purple
HF12087	120	87	90	0,61	Yellow
HF12090	120	90	93	0,58	Green
HF12093	120	93	96	0,55	Pink
HF12096	120	96	100	0,52	Brown

◆→ WAVE GUIDES

- ◆ Hawke manufacture a range of blocks to suit the most popular waveguides sizes. (See table) Please note that other sizes can be made to order. Please contact our Sales Department with details.
- ◆ Hawke wave guide insert blocks are used inserted in standard HF Blocks.
- ◆ To ease assembly and guarantee system performance it is a requirement that cables enter and exit the aperture perpendicular in all axis to the face of the frame.

Ref - Elliptical Waveguide	Major Axis mm	Minor Axis mm	Standard Tolerant Block Size Required For E.W, Insert
EW220	17,8	11,2	4031
EW132	24,4	15,5	4031
EW127A	28,2	17,1	4031
EW85	33,5	22,9	6049
EW77	43,6	25,4	6049
EW64	48,5	28,4	6049



◆ → BLANK BLOCKS

Hawke HF blank modules are designed to fill spaces within the frame which are not required for services, thus allowing spare capacity for future requirements.

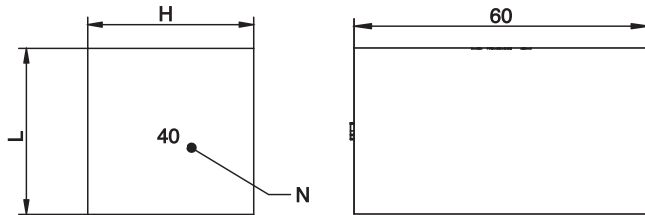

◆ → Blank blocks

TYPE	H (mm)	W (mm)	LABEL (N)	WEIGHT (kg)
HF150	15	15	15	0,02
HF200	20	20	20	0,03
HF300	30	30	30	0,08
HF400	40	40	40	0,14
HF600	60	60	60	0,31
HF900	90	90	90	0,71
HF1200	120	120	120	1,24
HF90-30*	90	30	90-30	0,24

*HF90-30 to be used along with a HF90 series tolerant block

◆ → Round corner blank blocks

TYPE	H (mm)	W (mm)	LABEL (N)	R (mm)	WEIGHT (kg)
HF200 R20	20	20	20	20	0,03
HF300 R20	30	30	30	20	0,07

◆ → Filler strips

TYPE	H (mm)	W (mm)	WEIGHT (kg)
HF50	5	60	0,03
HF100	10	60	0,11
HF100 (12x10)*	10	60	0,11

* HF100 precut into 12 pieces of 10x10mm blocks.

◆→ TREFOIL BLOCKS

Hawke trefoil blocks are used to accommodate three singles phase power cables within the same block. This negates eddy currents being induced into a ferrous steel frame thus negating heat induction within the frame.

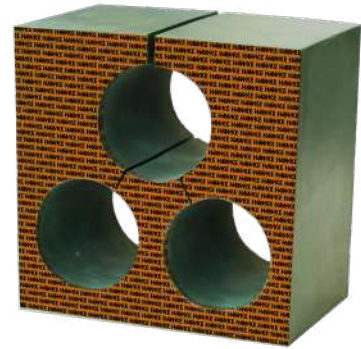
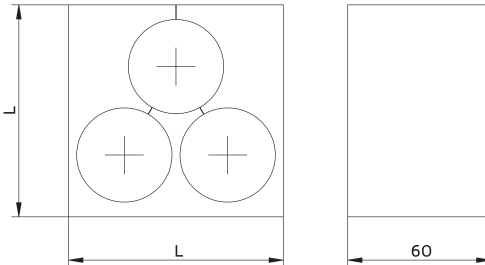

DESCRIPTION	L (mm)	CABLES DIAMETER (MM)	WEIGHT (KG)	COLOUR
HF80-3-28	80	28	-	Yellow
HF80-3-30	80	30	-	Purple
HF80-3-32	80	32	-	Brown
HF90-3-26	90	26	0,57	White
HF90-3-28	90	28	0,54	Blue
HF90-3-30	90	30	0,51	Pink
HF90-3-32	90	32	0,49	Red
HF90-3-34	90	34	0,46	Orange
HF90-3-36	90	36	0,43	Brown
HF90-3-38	90	38	0,4	Purple
HF90-3-40	90	40	0,37	Yellow
HF120-3-41	120	41	0,9	Red
HF120-3-43	120	43	0,86	White
HF120-3-45	120	45	0,83	Blue
HF120-3-47	120	47	0,79	Pink
HF120-3-49	120	49	0,75	Orange
HF120-3-51	120	51	0,71	Yellow

◆→ SPECIAL INSERT BLOCKS

- ◆ When Hawke Transit Frames are penetrated by services that are shaped anything other than circular, e.g. busbars, special cables, earthtraps, etc. Special blocks can be manufactured.
- ◆ All special blocks are tested in our laboratory to ensure viability and performance.
- ◆ Please contact our Sales Department for more information.



→ COMPRESSION SYSTEM

The Unique Hawke Compression System is used in rectangular frames to compress and seal the installation of cables/pipes within HF modules. It is composed by:

- **Endpacker:** The final element of the frame installation, this is inserted above the compression plate. The tightening of the bolts and the steel insert pins provides pressure to the system and ensures correct sealing.
- **Compression plate:** Placed on top of the last row of blocks, this plate distributes the pressure from the endpacker to ensure the correct compression is applied to the system.



CHARACTERISTICS

- ◆ Available in 120 and 60mm width (for 120 and 60 mm frames).
- ◆ Designed to be installed in all rectangular apertures.
- ◆ Materials: Mild Steel, Stainless Steel.

◆ → Endpacker 1642B

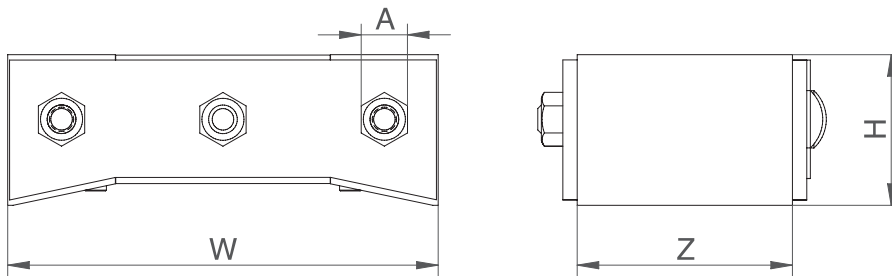

◆ → Compression plate 1642A

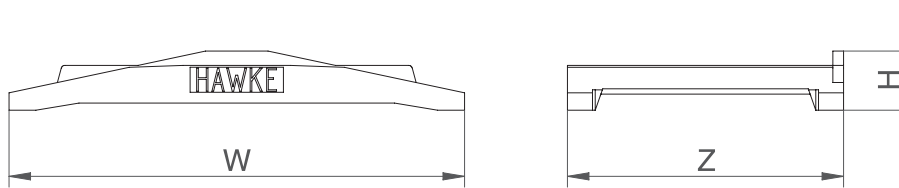

DESCRIPTION		External dimensions				A	Weight (kg)	
		Qty	W [mm]	H [mm]	Z [mm]		Mild steel	Stainless steel
Compression System/1642 120 mm	Endpacker/1642B 120	1	120	42	60	13	0,8	0,8
	Compression Plate/1642A 120	1	127	17	77	-	0,4	0,4
Compression System/1642 60 mm	Endpacker/1642B 60	1	60	42	60	13	0,4	0,4
	Compression Plate/1642A 60	1	64	17	77	-	0,2	0,2
Compression System/962 180 mm	Endpacker/962B 180	1	180	42	60	13	1,2	1,2
	Compression Plate/962A 180	1	187	19	81	-	0,6	0,6
Compression System/963 240 mm	Endpacker/963B 240	1	240	42	60	13	1,5	1,5
	Compression Plate/963A 240	1	247	19	81	-	0,9	0,9
Compression System/964 360 mm	Endpacker/964B 360	1	360	42	60	13	2,3	2,3
	Compression Plate/964A 360	1	267	19	81	-	1,3	1,3

* For separate parts adquisition, contact sales department

◆ → ROUND CORNER COMPRESSION SYSTEM

The Unique Hawke Round Corner Compression System is used in HMCX rectangular frames to compress and seal the installation of cables/pipes and HF modules. It is composed by:

- **Endpacker:** The final element of the frame installation, this is inserted above the compression plate. The tightening of the bolts and the steel insert pins provides pressure to the system and ensures correct sealing.
- **Compression plate:** Placed on top of the last row of blocks, this plate distributes the pressure from the endpacker to ensure the correct compression is applied to the system.



CHARACTERISTICS

- ◆ Available in the following variants; RR (Right round corner), LR (Left round corner) and DR (Double rounded), for the different kinds of apertures within a HMCX frame.
- ◆ Designed to be installed within HMCX apertures.
- ◆ Materials: Mild Steel, Stainless Steel.

◆ → Endpacker double rounded 1642B DR

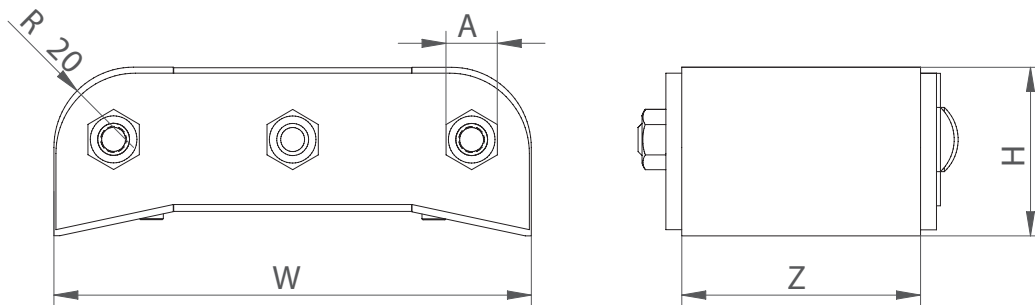

◆ → Endpacker left round corner 1642B LR

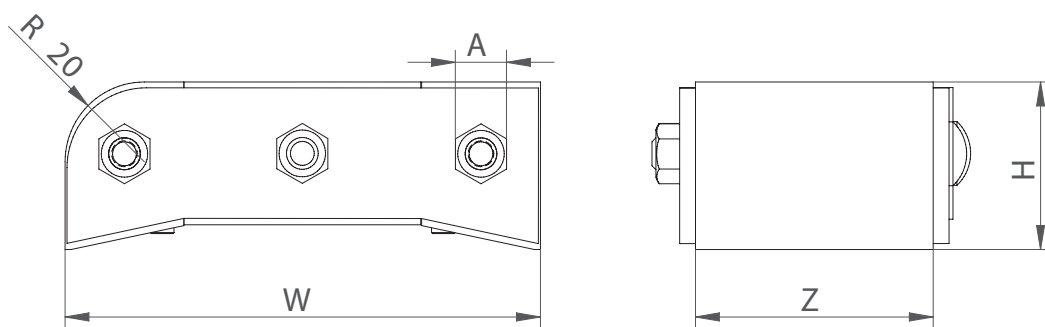

ROUND CORNER COMPRESSION SYSTEM

◆ Endpacker right round corner 1642B RR

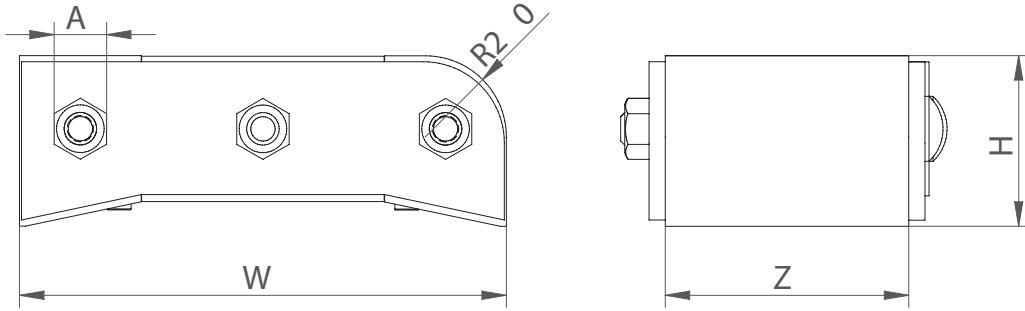

◆ Compression plate 1642A

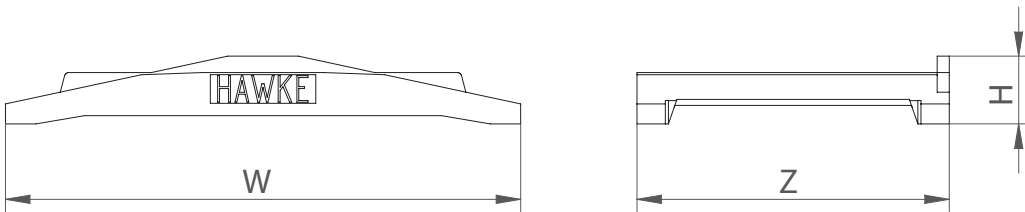

DESCRIPTION		External dimensions				A	Weight (kg)	
		Qty	W [mm]	H [mm]	Z [mm]		Mild steel	Stainless steel
Compression System Double Round/1642 DR	Endpacker/1642B DR	1	120	42		13	0,8	0,8
	Compression Plate/1642A	1	127	17	77	-	0,4	0,4
Compression System Left Round/1642 LR	Endpacker/1642B LR	1	120	42		13	0,8	0,8
	Compression Plate/1642A	1	127	17	77	-	0,4	0,4
Compression System Right Round/1642 RR	Endpacker/1642B RR	1	120	42		13	0,8	0,8
	Compression Plate/1642A	1	127	17	77	-	0,4	0,4

* For spare parts adquisition, contact sales department

◆→ STAYPLATES

Stayplates ensure the blocks in a Hawke rectangular system (tolerant and blank ones) are fixed in position after compression. A stayplate should be placed above each complete row of insert/filler blocks. However, never on the last top row (underneath the compression plate) and never below the last bottom row of blocks.

- ◆ Available in AISI 304 stainless steel. AISI 316 and other materials under request.
- ◆ High pressure stayplates (931P) are to be used in applications where the pressure requirement is greater than 3.5 bar.



◆→ Hawke standard Stayplate

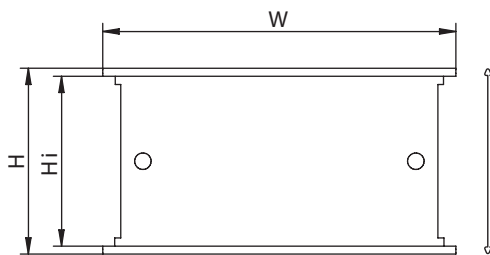

◆→ Hawke high pressure Stayplate

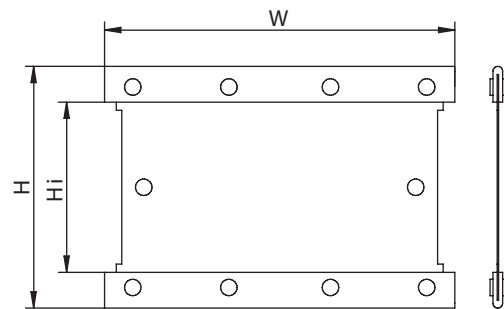

DESCRIPTION	W (mm)	H (mm)	Hi (mm)
Stayplate 931 60mm	68	68	62
Stayplate 931 120mm	128	68	62
High Pressure Stayplate 931/P 120mm	128	88	62
Stayplate 931 180mm	188	68	62
Stayplate 931 240mm	248	68	62
Stayplate 931 360mm	368	68	62

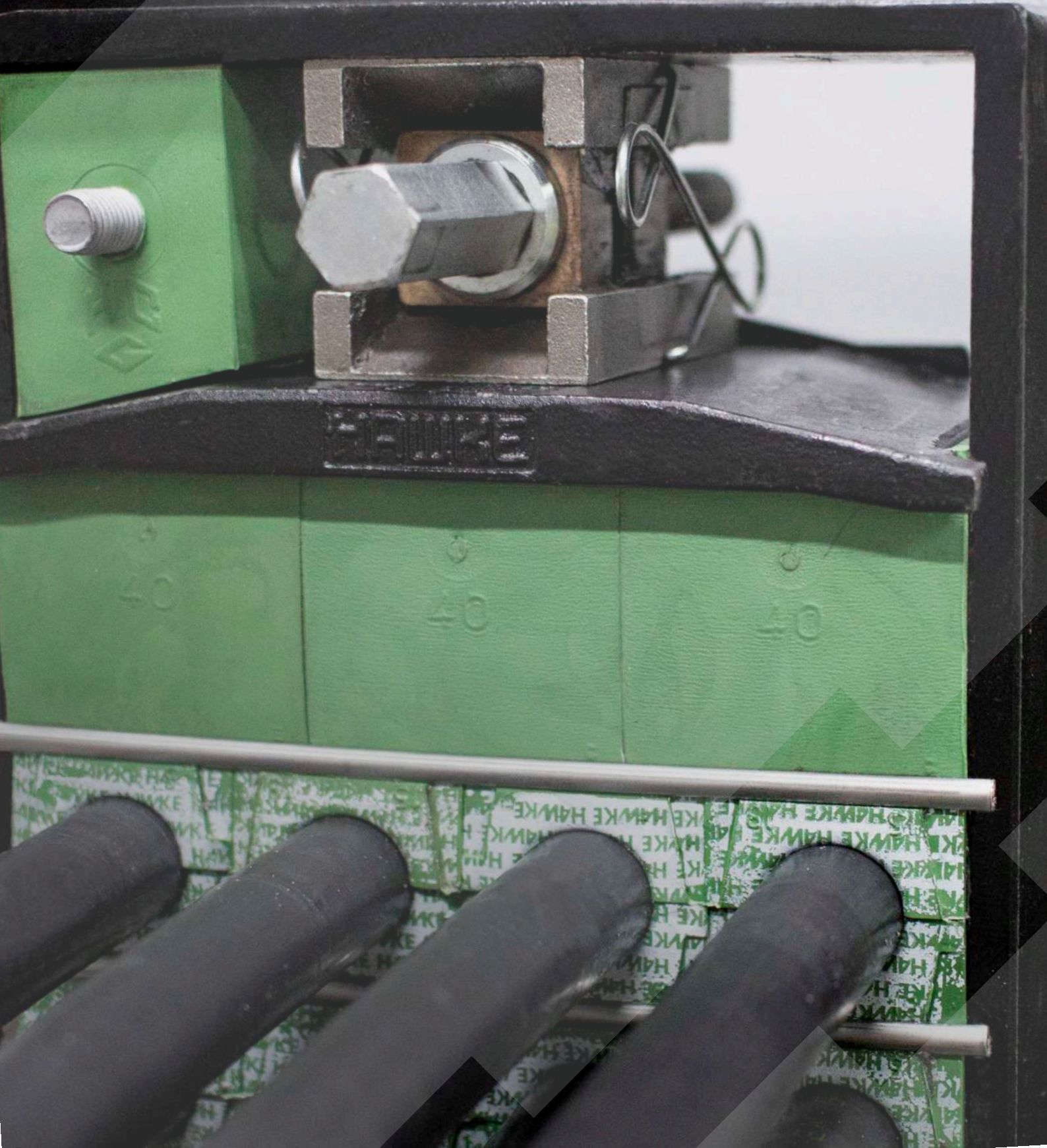

ACCESSORIES

◆ → **COMPRESSION TOOL**

This re-usable compression tool is designed to apply compression to the system before placing the endpacker within the frame.

This makes the operation of installing the compression system much easier than a conventional bolt-type system.

- ◆ Available in two versions for different frame internal width; 60mm (Ref. 982) and 120mm (Ref. 981).

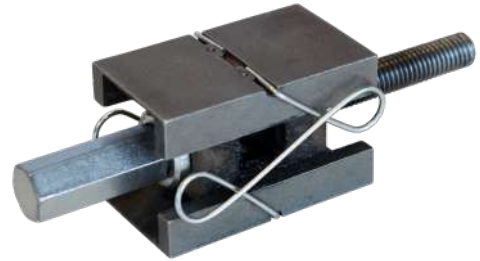

◆ → **PULLER**

The Puller Tool (Ref. 980) is used to facilitate the modification or dismantling of an installation.

This re-usable tool is designed to extract the compression system without damaging the frame and reducing dismantling time up to 50%. This also means that you can re-use the Hawke compression system.



◆ → **CLAMP TOOL**

The Clamp Tool (Ref. 969) is used to aid onsite installation.

This re-usable tool is designed to hold the blocks or cables in position during an installation, especially useful in horizontal frames, partial installations or when the amount of cables makes the installation uneasy.

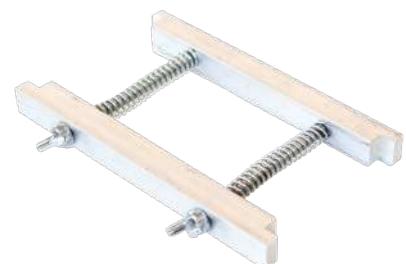

◆ → WELDING FIXING TOOL

The Welding Fixing (Ref. 974) Tool is used to facilitate the welding process on a marine frame.

This re-usable tool is designed to hold the frame in position during the welding process, avoiding deformations due to high temperature.



◆ → LUBRICANT

Hawke Lubricant (Ref. 967) is used to facilitate positioning the blocks and elements of a transit during an installation.

The lubricant remains soft and will not dry out with the passing of time, ensuring that future modifications or dismantling will not be impeded.



◆→ **SILICONE FIREPROOF SEALANT**

Hawke Silicone Fireproof Sealant (Ref. 962) is used to secure installation in marine bolted frames and civil bolted frames and sleeves.

Fireproof sealant should be applied between the flange of the frame and the structure to ensure a tight seal and avoid possible gaps.



◆→ **MASTIC**

Hawke Mastic (Ref. 966) is used to secure installation in civil bolted frames and sleeves.

Mastic should be applied between the flange of the frame and the structure to ensure a tight seal and avoid possible gaps.



◆ → BACKING PLATE

Hawke Backing Plates (Ref. TABP) are used in conjunction with Hawke flanged frames to add finished appearance to an installation.

Backing plates are designed to be installed on the opposite side of a frame, giving a wall or structure finished appearance.

Length (thickness of wall) and frame model should be indicated when ordering.

Reference	Frame Size
TABP 2	2
TABP 4	4
TABP 6	6
TABP 8	8

◆ Also available in multiple aperture frame sizes.



◆ → POLYSTYRENE MOULD

Hawke Polystyrene moulds are used to protect the inside of a frame during a casted installation in a floor or wall.

Reference	Type	Frame Size
965/2	Rectangular	2
965/4	Rectangular	4
965/6	Rectangular	6
965/8	Rectangular	8
962/30	Round	30
962/40	Round	40
962/50	Round	50
962/70	Round	70
962/100	Round	100
962/125	Round	125
962/150	Round	150
962/175	Round	175
962/200	Round	200





EMC TRANSIT SYSTEMS

EMC HAWKE TRANSIT SYSTEMS



The need to protect sensitive electronic equipment against extraneous electromagnetic and radio frequency radiation is an increasing and critical factor in the design of equipment and installations.

A major concern is to ensure the integrity of operation of the equipment such as computers, signal control and communication systems by effective sealing and low resistance earth continuity bonding at cable and pipe entry points of a low "noise" environment.

Electromagnetic compatibility (EMC) is the term used to express the ability of electronic equipment or systems to operate satisfactorily in a given environment without responding to electrical noise or emitting unwanted noise.

EMC is achieved by reducing the Electromagnetic interference (EMI) to a level which in most applications will not disrupt the proper operation of the electronic devices.

The Hawke EMC Cable Transit System. Hawke's system has been further developed from the highly successful Civil and Marine Transits which are equally suitable for cables or pipes.

CHARACTERISTICS

- ◆ As well as acting as a certified fire, water and gas barrier, the Hawke EMC Multi Cable Transit System (EMC MCT) provide protection against electromagnetic pulses, electronic sabotage, noise, etc.
- ◆ Essential to ensure the integrity of electronic devices, computers and military communication systems.
- ◆ Just like HF blocks, EMC HF tolerant blocks have a cable sealing range of 3mm to 100mm without the need of any on-site modifications. EMC blocks are coated with a highly conductive silver-loaded paint to capture any airborne electrical noise.
- ◆ Copper tape provides a high conductive path from cable screen to frame, and stainless steel frames allow conductivity from blocks to earth.



Frame:

Hawke frame is attached to the structure and forms the surround of the penetration, allowing the system to compress and content the pressure. To guarantee correct EMC sealing, stainless steel is recommended by HTS to ensure good conductivity and a good connection of all the system to earth.

Compression system:

Needed to apply pressure to the system and complete the seal once the rest of the services have been installed. The 3 part endpacker transmits an evenly distributed pressure onto the compression plate, and ensures an effective seal around the cables. The conductive coat and the copper tape guarantee that the EMC requirements are maintained.

Stayplates:

Installed to anchor insert and filler blocks into the frame and ease assembly, stainless steel stayplates also increase the conductance throughout the system to ensure effective shielding and EMI protection.

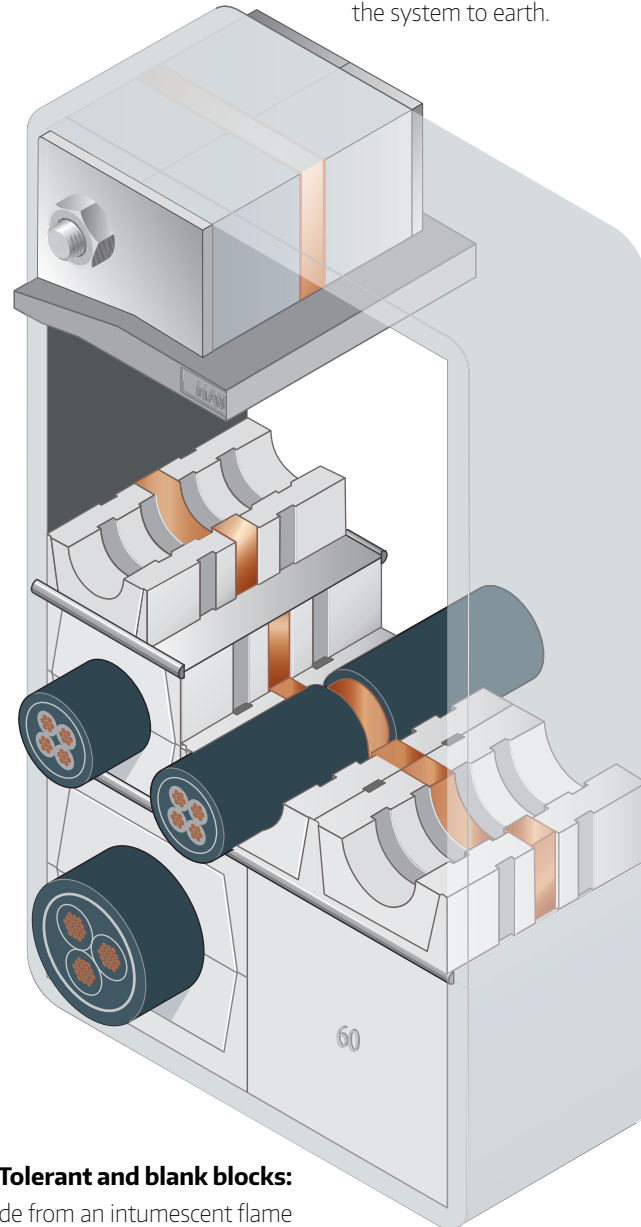

Adhesive copper strip:

Provided to build up the insert blocks and the stripped cable. All the cables require the removal of the outer sheath to achieve contact between the cable screen and the blocks. The copper EMI shielding tape with conductive adhesive is wrapper around the cable screen until the nominal outside diameter of the cable is achieved. This is important to ensure complete conductance of the electromagnetic pulses/fields in the inner walls of the steel frame against the earth.

Tolerant and blank blocks:

Made from an intumescent flame retardant elastomer, coated with silver loaded conductive coat and wrapped with conductive copper tape, EMC HF blocks provide excellent shielding and EMC protection, along with the standard requirements of HF blocks against water, fire, etc.

Hawke tolerant blocks have a cable range of 3mm to 100mm without the need of any onsite modifications, reducing the time of installation up to several times compared with the competitors, and eliminating wastes.

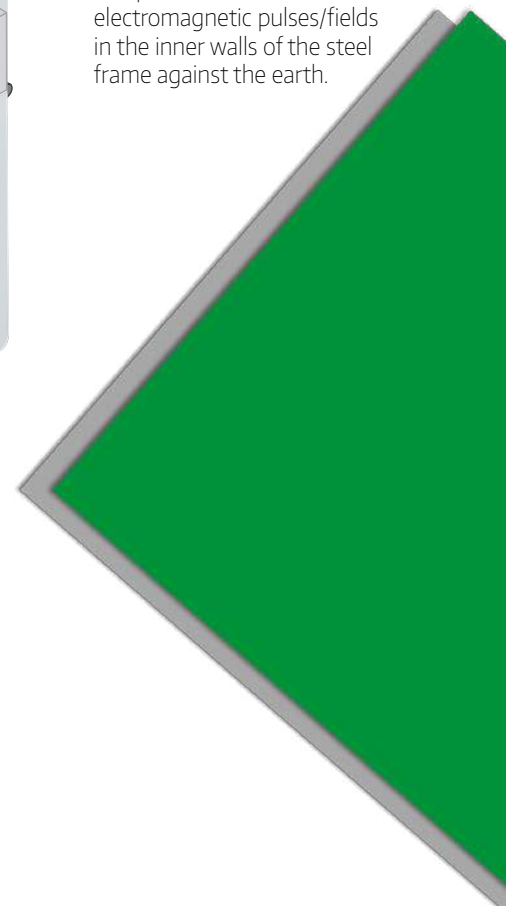

EMC Frames

Hawke frames are attached to the structure and form the surround of the penetrations, allowing the systems to compress and content the pressure, and giving a conductive path from the cable screen and the surface of the blocks to the earth.

All standard HTS marine and civil frames are able to be used in EMC systems.

Stainless Steel is highly recommended for EMC applications.



◆ **MARINE**

- ◆ HMX.....18
- ◆ HMOX.....20
- ◆ HMFx.....22
- ◆ HMFbX.....24
- ◆ HMEX.....26
- ◆ HMBX.....28
- ◆ HMCX.....30
- ◆ HMRX TB32

◆ **CIVIL**

- ◆ HCX40
- ◆ HCOX.....42
- ◆ HCLX.....44
- ◆ HCLOX.....45

◆ **SLEEVES**

- ◆ C56
- ◆ CB58
- ◆ CBO.....60
- ◆ CBC62

◆→ TOLERANT BLOCKS

Hawke HF EMC tolerant blocks are designed to accommodate different cables passing through the frame.

Its special design with five contact points allows the blocks to accommodate different diameters within the same block and accept variances in cable/pipe diameters.

Silver-loaded paint and copper strip wrapping ensures correct shielding.



CHARACTERISTICS

- ◆ Made of zero halogen, intumescent elastomeric polymer.
- ◆ No modification of the block needed during installation. Zero waste.
- ◆ Sealing grooves in the internal faces ensures correct contact all along your cable.

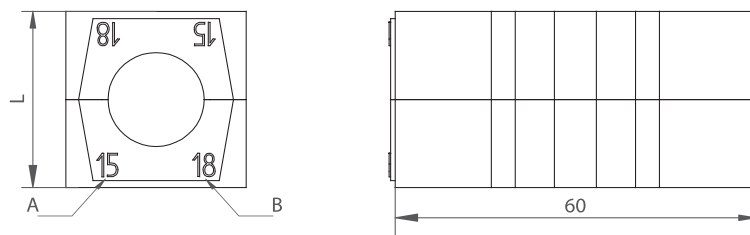

DESCRIPTION	L (mm)	CABLE AND PIPE DIAMETER		WEIGHT (kg)
		LABEL A MINIMUM (mm)	LABEL B MAXIMUM (mm)	
HF153/E	15	3	5	0,02
HF155/E	15	5	7	0,02
HF157/E	15	7	9	0,01
HF203/E	20	3	6	0,03
HF206/E	20	6	9	0,03
HF209/E	20	9	12	0,03
HF2011/E	20	11	14	0,02
HF2013/E	20	13	16	0,02
HF3012/E	30	12	15	0,05
HF3015/E	30	15	18	0,06
HF3018/E	30	18	21	0,05
HF3021/E	30	21	24	0,04
HF4012/E	40	12	15	0,12
HF4015/E	40	15	18	0,12
HF4022/E	40	22	25	0,10
HF4025/E	40	25	28	0,09
HF4028/E	40	28	31	0,08

→ TOLERANT BLOCKS

DESCRIPTION	L (mm)	CABLE AND PIPE DIAMETER		WEIGHT (kg)	COLOUR
		LABEL A	LABEL B		
		MINIMUM (mm)	MAXIMUM (mm)		
HF4031	40	31	34	0,07	Orange
HF6031	60	31	34	0,22	Red
HF6034	60	34	37	0,21	White
HF6037	60	37	40	0,20	Blue
HF6040	60	40	43	0,19	Orange
HF6043	60	43	46	0,18	Purple
HF6046	60	46	49	0,16	Yellow
HF6049	60	49	52	0,14	Green
HF6052	60	52	54	0,11	Pink
HF9053	90	53	56	0,46	Red
HF9056	90	56	59	0,44	White
HF9059	90	59	62	0,42	Blue
HF9062	90	62	65	0,40	Orange
HF9065	90	65	68	0,39	Purple
HF9068	90	68	71	0,36	Yellow
HF12072	120	72	75	0,79	Red
HF12075	120	75	78	0,75	White
HF12078	120	78	81	0,71	Blue
HF12081	120	81	84	0,67	Orange
HF12084	120	84	87	0,64	Purple
HF12087	120	87	90	0,61	Yellow
HF12090	120	90	93	0,58	Green
HF12093	120	93	96	0,55	Pink
HF12096	120	96	100	0,52	Brown

◆ → BLANK BLOCKS

Hawke HF EMC blank modules are designed to fill spaces within the frame which are not required for services, thus allowing spare capacity for future requirements. Silver-loaded paint and copper strip wrapping ensures correct shielding.

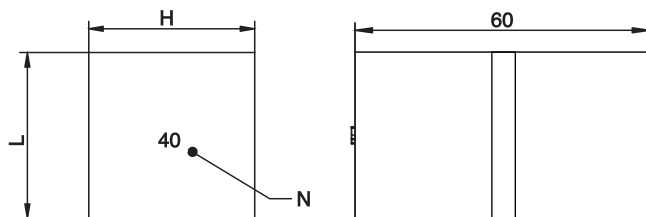

◆ → Blank blocks

TYPE	H (mm)	W (mm)	LABEL (N)	WEIGHT (kg)
HF150/E	15	15	15	0,02
HF200/E	20	20	20	0,03
HF300/E	30	30	30	0,08
HF400/E	40	40	40	0,14
HF600/E	60	60	60	0,31
HF900/E	90	90	90	0,71
HF1200/E	120	120	120	1,24
HF90-30/E*	90	30	90-30	0,24

*HF90-30/E to be used along with a HF90 series tolerant block

◆ → Round corner blank blocks

TYPE	H (mm)	W (mm)	LABEL (N)	R (mm)	WEIGHT (kg)
HF200/E R20	20	20	20	20	0,03
HF300/E R20	30	30	30	20	0,07

◆ → Filler strips

TYPE	H (mm)	W (mm)	WEIGHT (kg)
HF50/E	5	60	0,03
HF100/E	10	60	0,11
HF100/E (12x10)*	10	60	0,11

* HF100/E precut into 12 pieces of 10x10mm blocks.

→ COMPRESSION SYSTEM

The Unique Hawke EMC Compression Systems are used in rectangular frames to compress and seal the installation of cables/pipes and HF EMC modules when electromagnetic compatibility is needed.

- **Endpacker:** The final element of the frame installation, this is inserted above the compression plate. The tightening of the bolts and the steel insert pins provides pressure to the system and ensures correct sealing.

Silver-loaded paint and copper strip wrapping ensures effective shielding.

- **Compression plate:** Placed on the top of the last row of blocks, this plate distributes the pressure from the endpacker to the whole system.



CHARACTERISTICS

- ◆ Available in the different models: Standard, RR (Right round corner), LR (Left round corner) and DR (Double rounded), for the different kind of apertures in a frame.
- ◆ Designed to be installed in all rectangular apertures.
- ◆ Materials: Stainless Steel.

◆ → Endpacker 1642B/ES

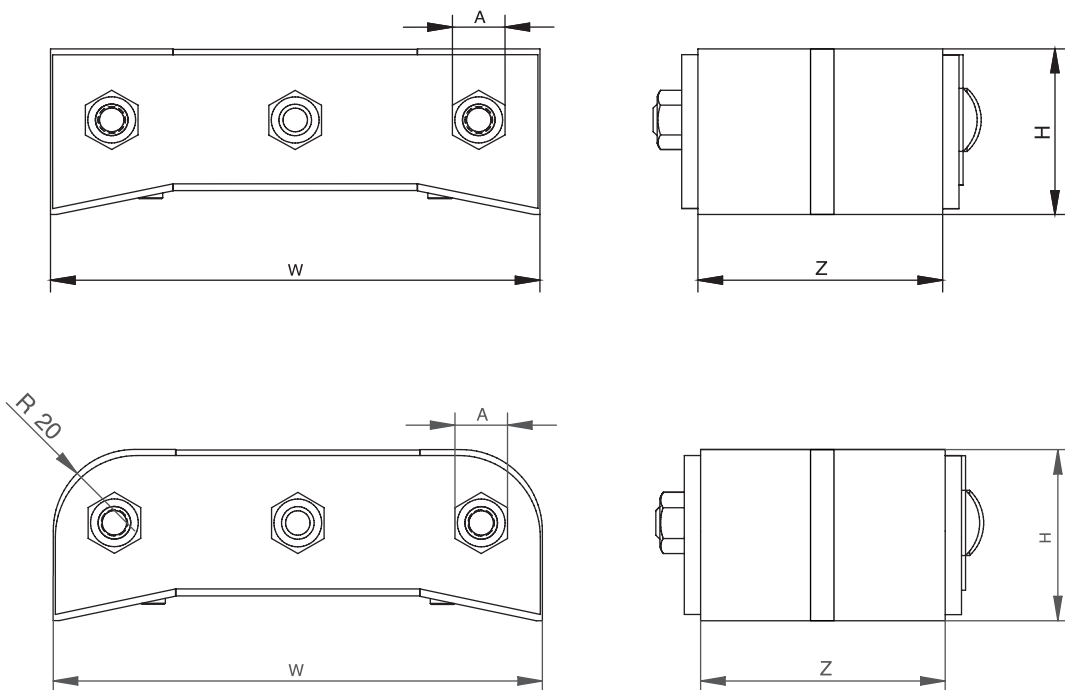

→ COMPRESSION SYSTEM

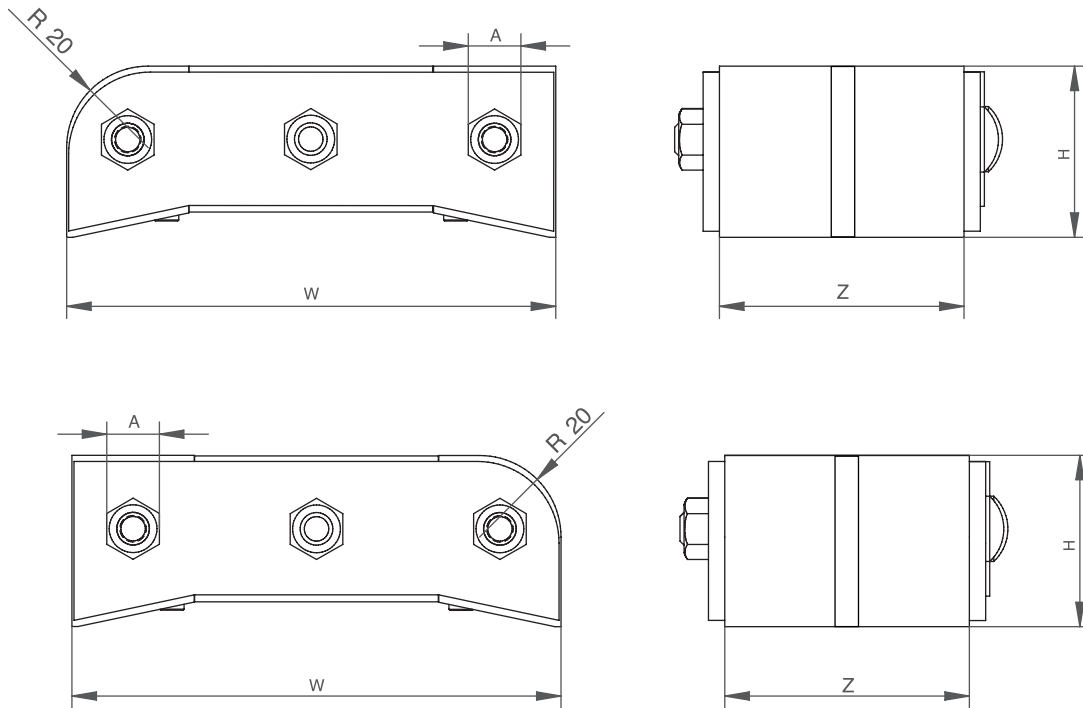

◆ → Compression plate 1642A/ES

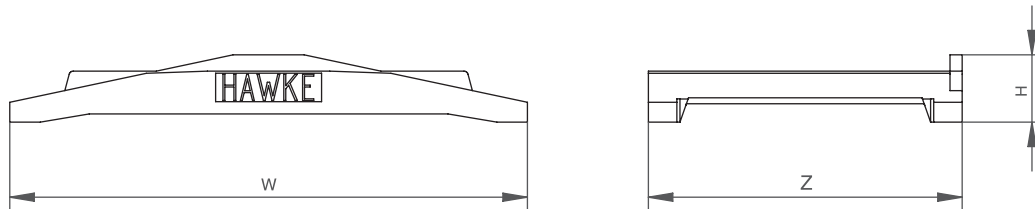

DESCRIPTION		External dimensions				A	Weight (kg)	
		Qty	W [mm]	H [mm]	Z [mm]		Mild steel	Stainless steel
Compression System 1642/ES 120 mm	Endpacker/1642B/ES 120	1	120	42	60	13	0,8	0,8
	Compression Plate/1642A/ES 120	1	127	17	77	-	0,4	0,4
Compression System Double Round/1642/ES DR	Endpacker/1642B/ES DR	1	120	42		13	0,8	0,8
	Compression Plate/1642A/ES	1	127	17	77	-	0,4	0,4
Compression System Left Round/1642/ES LR	Endpacker/1642B/ES LR	1	120	42		13	0,8	0,8
	Compression Plate/1642A/ES	1	127	17	77	-	0,4	0,4
Compression System Right Round/1642/ES RR	Endpacker/1642B/ES RR	1	120	42		13	0,8	0,8
	Compression Plate/1642A/ES	1	127	17	77	-	0,4	0,4

* For separate parts acquisition, contact sales department

STAYPLATES

Stayplates ensure the blocks in a Hawke rectangular system (tolerant and blank ones) are fixed in position after compression.

A stayplate should be placed above each complete row of insert/filler blocks. However, never on the last top row (underneath the compression plate) and never below the last bottom row of blocks.

- ◆ Available in AISI 304 stainless steel. AISI 316 and other materials under request.
- ◆ High pressure stayplates (Ref.931/P) are to be used in applications where the pressure requirement is greater than 3.5 bar.



Hawke standard Stayplate

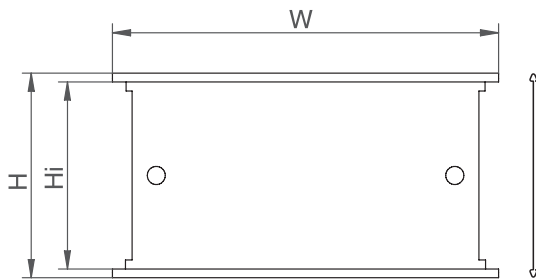

Hawke high pressure Stayplate

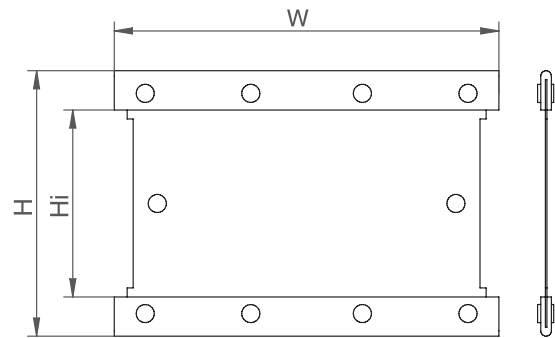

DESCRIPTION	W (mm)	H (mm)	Hi (mm)
Stayplate 931 60mm	68	68	62
Stayplate 931 120mm	128	68	62
High Pressure Stayplate 931/P 120mm	128	88	62

EMC MARKING TOOL

The EMC Marking tool (Ref. 970) is used to facilitate installation of cables within an EMC system.

This re-usable tool is designed to mark the area where cable sheath should be removed to wrap the copper tape, and to mark the cable in both ends of the frame to guarantee that blocks a cable copper tape are aligned.

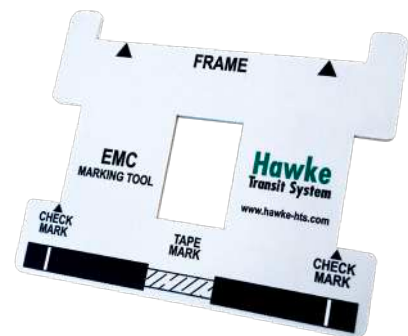

◆→ EMC CABLE SHEATH REMOVE TOOL

This re-usable tool is designed to remove the cable sheath with precision and without damaging the cable screen.



Description	Cable diameter	
	Minimum (mm)	Maximum (mm)
Cable sheath remove tool 972/A	4	22
Cable sheath remove tool 972/B	6	32
Cable sheath remove tool 972/C	10	64

◆→ EMC COPPER TAPE

Hawke Copper Tape (Ref. 950) is used in EMC systems to fill the gap between the cable screen and the EMC HF block after cable sheath has been removed.

It provides a high conductive path from cable screen to earth.



HRTO EMC

Hawke EMC HRTO is a round sealing solution for multiple cables/ pipes passing through a circular aperture in a wall or bulkhead/deck, to be used when electromagnetic compatibility (EMC) is needed.

The seal is formed by tightening the compression bolts which expand the system radially with no need of a compression system, and copper tape provides high conductive path from cable screen to earth, avoiding interferences and noise.

CHARACTERISTICS

- ◆ Designed to be installed using Hawke Sleeves (welded, bolted or casted) and EMC HF blocks.
- ◆ Manufactured in intumescent elastomer polymer with stainless steel front and back plates. Plates also available in mild steel.
- ◆ HRTO is always supplied as an open frame. This enables the frame to be installed after cable/pipe installation.
- ◆ No extra tools are required for its installation.

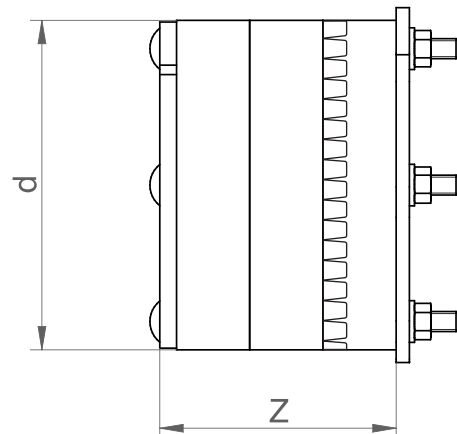
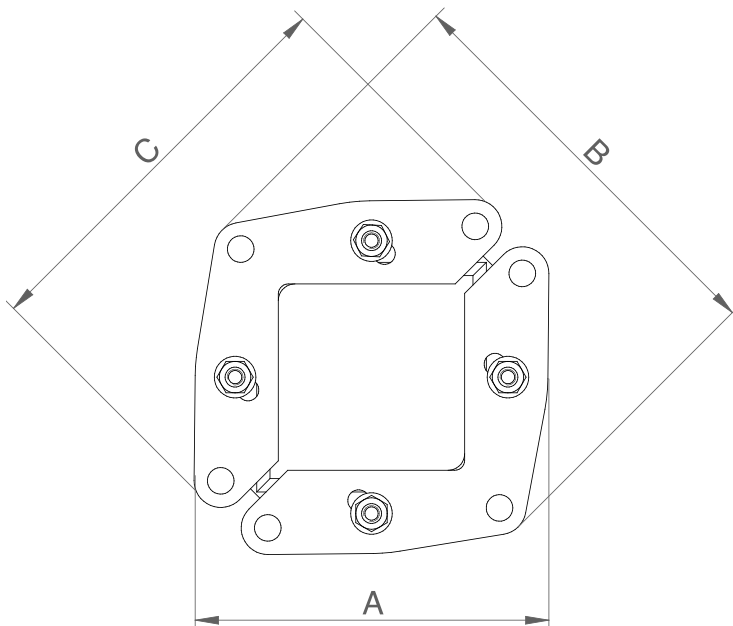
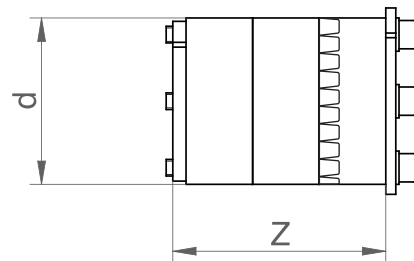
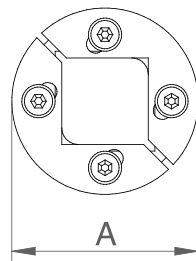

HRTO EMC

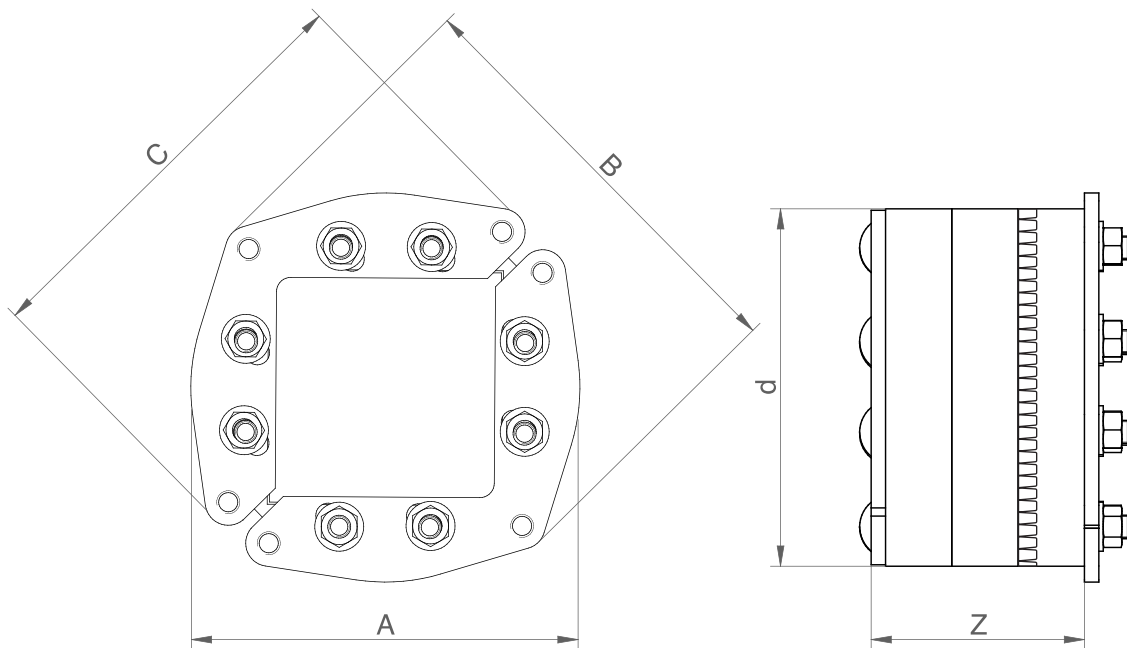

DESCRIPTION	SLEEVE SIZE NEEDED	A (mm)	B (mm)	C (mm)	d (mm)	Z (mm)	Weight (kg)
HRTO-30/ES	30	36	-	-	32	64	0,11
HRTO-40/ES	40	46	-	-	40	64	0,15
HRTO-50/ES	50	56	-	-	50	64	0,2
HRTO-70/ES	70	85	105	50	70	70	0,5
HRTO-100/ES	100	108	137	94	100	70	0,8
HRTO-125/ES	125	150	163	124	125	74	0,95
HRTO-150/ES	150	160	187	179	150	74	1,9
HRTO-200/ES	200	210	237	226	200	74	3,7

*All dimensions are nominal values

Sealing Area

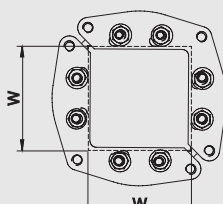

TYPE	SEALING AREA (mm)
HRTO-30	15x15
HRTO-40	20x20
HRTO-50	30x30
HRTO-70	40x40
HRTO-100	60x60
HRTO-125	80x80
HRTO-150	90x90
HRTO-200	120x120

Installation references

	page
See assembly parts	66
See accessories	76
See installation guide	135
See inspection check	160

HRST EMC

Hawke EMC HRST is a round sealing solution for a single cable/pipe passing through a wall or bulkhead/deck.

It is to be used when electromagnetic compatibility (EMC) is needed. Copper tape provides a high conductive path from cable screen to earth, avoiding interferences and noise.

Each size of HRST frame can seal a large range of diameters without any onsite modifications.

CHARACTERISTICS

- ◆ Available to seal services from 4mm up to 170mm of external diameter, in standard version.
- ◆ Designed to be installed using Hawke Sleeves (welded, bolted or casted).
- ◆ Manufactured in intumescent elastomer polymer with stainless steel front and back plates. Each HRST frame has a gasket to prevent galvanic corrosion when installed within a mild steel sleeve.
- ◆ HRST is always supplied as an open frame. This enables the frame to be installed after cable/pipe installation.
- ◆ No extra tools are required for its installation.

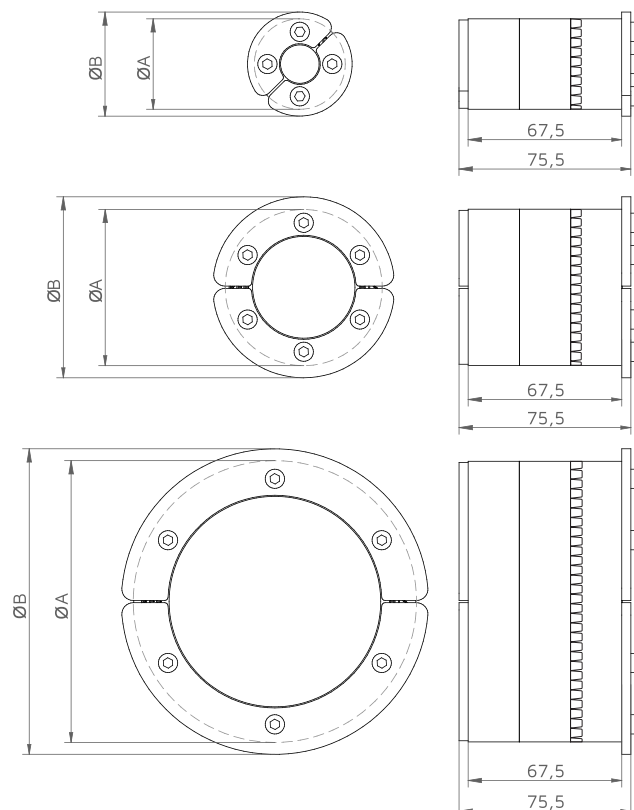

HRST EMC

DESCRIPTION	SLEEVE SIZE NEEDED	SEALING FROM (mm)	SEALING TO (mm)	A (mm)	B (mm)	WEIGHT (kg)	COLOUR
HRST-30/4/ES	30	4	10	32	36	0,16	White
HRST-30/7/ES	30	7	14	32	36	0,15	Red
HRST-30/10/ES	30	10	17	32	36	0,14	Blue
HRST-40/4/ES	40	4	10	40	46	0,24	Purple
HRST-40/7/ES	40	7	14	40	46	0,23	yellow
HRST-40/10/ES	40	10	17	40	46	0,21	Green
HRST-40/17/ES	40	17	24	40	46	0,18	Pink
HRST-50/4/ES	50	4	10	50	56	0,35	Red
HRST-50/10/ES	50	10	17	50	56	0,33	White
HRST-50/17/ES	50	17	24	50	56	0,29	Blue
HRST-50/24/ES	50	24	30	50	56	0,25	Orange
HRST-70/26/ES	70	26	33	69	80	0,56	Purple
HRST-70/33/ES	70	33	39	69	80	0,50	Yellow
HRST-70/39/ES	70	39	45	69	80	0,44	Green
HRST-70/45/ES	70	45	50	69	80	0,38	Pink
HRST-100/48/ES	100	48	55	99	110	0,96	Red
HRST-100/55/ES	100	55	61	99	110	0,87	White
HRST-100/61/ES	100	61	66	99	110	0,79	Blue
HRST-100/66/ES	100	66	71	99	110	0,71	Orange
HRST-125/64/ES	125	64	71	124	135	1,42	Purple
HRST-125/71/ES	125	71	79	124	135	1,27	Yellow
HRST-125/79/ES	125	79	86	124	135	1,12	Green
HRST-125/86/ES	125	86	93	124	135	0,96	Pink
HRST-125/93/ES	125	93	98	124	135	0,84	Orange
HRST-150/93/ES	150	93	102	149	160	1,79	Red
HRST-150/102/ES	150	102	108	149	160	1,63	White
HRST-150/108/ES	150	108	115	149	160	1,43	Blue
HRST-150/115/ES	150	115	120	149	160	1,28	Orange
HRST-175/118/ES	175	118	125	174	185	2,16	Purple
HRST-175/125/ES	175	125	132	174	185	1,93	Yellow
HRST-175/132/ES	175	132	138	174	185	1,72	Green
HRST-175/138/ES	175	138	145	174	185	1,47	Pink
HRST-200/136/ES	200	136	143	199	210	2,73	Red
HRST-200/143/ES	200	143	150	199	210	2,48	White
HRST-200/150/ES	200	150	157	199	210	2,20	Blue
HRST-200/157/ES	200	157	164	199	210	1,92	Orange
HRST-200/164/ES	200	164	170	199	210	1,67	Yellow

*All dimensions are nominal values

Installation references

	page
See assembly parts	66
See accessories	76
See installation guide	135
See inspection check	162



DUCT SEAL

DUCT Seal

Hawke Duct Seal is a sealing system for cables passing through ducts or pipes, which ensures cabling is protected from water, smoke, corrosive chemicals, rodents and debris.

Tried and tested in the field, Duct Seal is suitable for a wide range of cable including optical fiber, electrical wire, twisted pair or coax, Its typical applications range from telecommunications to power distribution.

CHARACTERISTICS

- ◆ Each Duct Seal is provided with up to 4 apertures for cables or grommets.
- ◆ Designed to be installed on both ends of a duct or pipe.
- ◆ Available with integral test valve with unique central position maintaining utilization of all 4 ports, unlike other products in the market.
- ◆ Available in open version (Duct Seal and plugs) for retrofit installations, when cables are already in position.
- ◆ Manufactured in elastomer polymer with stainless steel front and back plates, with nickel plated brass valves, which consequently, prevents corrosion.
- ◆ No extra tools are required for its installation.
- ◆ The 50/11 and 50/13 duct seals give an airtight and watertight seal up to 2 bars. 4 port design tested to 1 bar as standard.
- ◆ Suitable for ducting used within concrete maintenance chambers, kerb side cabinets and civil installations.



Description		Duct/pipe inside diameter (mm)	Number of apertures	Aperture diameter (mm)
Without valve	With valve			
90/4	90/4/V	89-90	4	2x34 & 2x23
93/4	93/4/V	92-93	4	34
95/4	95/4/V	94-95	4	34
97/4	97/4/V	97	4	34
100/4	100/4/V	100	4	34
106/4	106/4/V	105-106	4	34
50/11/11	-	50	2	2x11
50/11/13	-	50	2	1x11 & 1x13
50/13/13	-	50	2	2x13

DUCT Seal

Duct Seal Cable Grommet

Description	Cable diameter		Number of cables
	Minimum (mm)	Maximum (mm)	
23/1*	6	9.5	1
23/2*	9	12.5	1
23/3*	12	15.5	1
23/4*	15	18	1
34/1	9	12.5	1
34/2	12	15.5	1
34/3	15	18.5	1
34/4	18	21.5	1
34/5	21	24.5	1
34/6	24	27.5	1
34/7	27	30	1
344x10	10	10	4

* For use with 90/4 Duct Seal



DUCT SEAL

Duct Seal Filler plugs

Description		Aperture diameter (mm)
Without valve	With valve	
34	34/V	34
23	23/V	23
13	13/V	13
11	11/V	11



- ◆ Other frames, seal grommets or plugs sizes available under request. Please contact Hawke Sales Department.

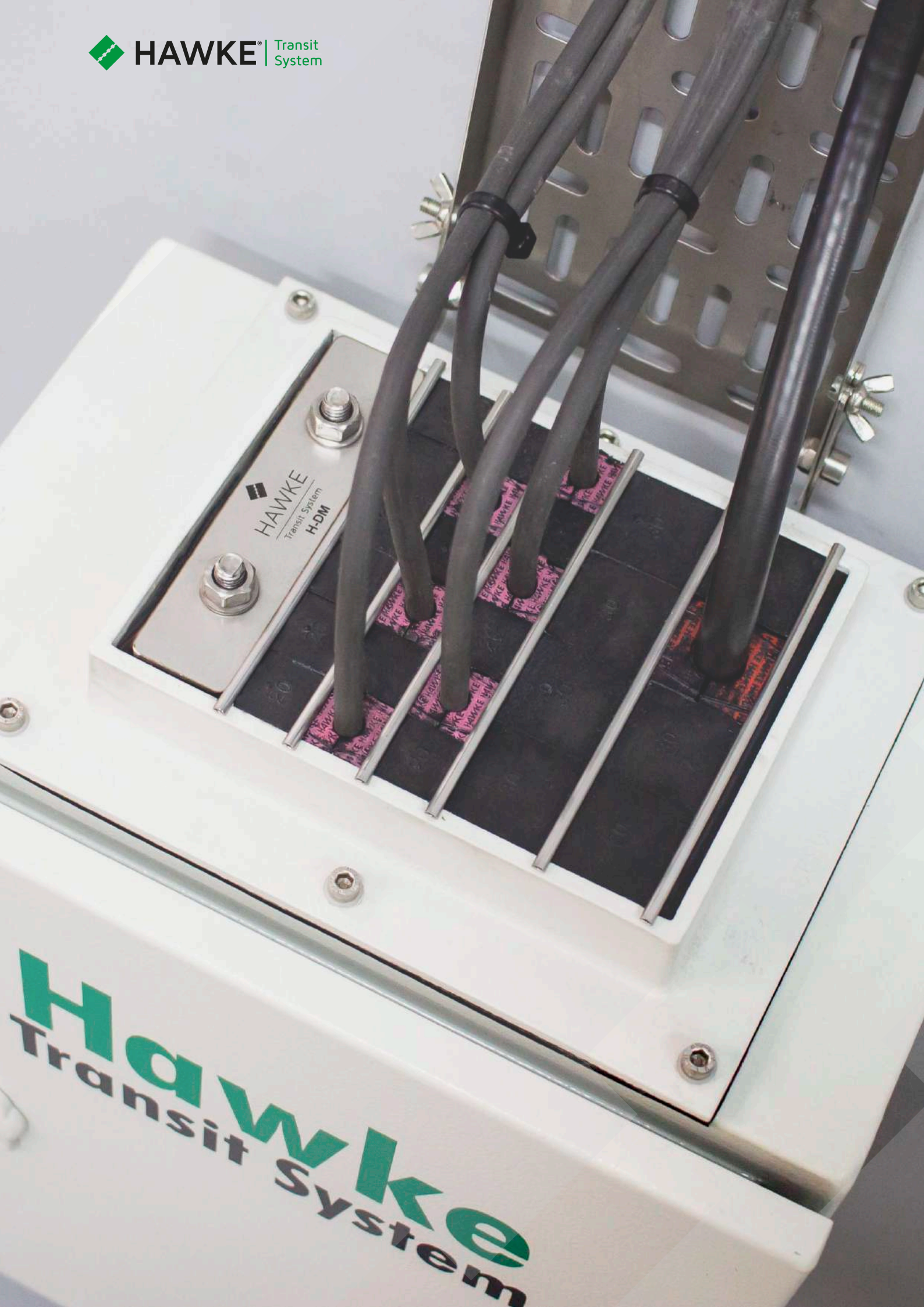

 **HAWKE**
Transit System
H-DM

Hawke
Transit System

CABINET SEALS

H-DM Frame

Hawke H-DM is a low weight cable sealing solution, designed for the sealing of electrical panel boards and cabinets against external conditions.

CHARACTERISTICS

- ◆ Available in three standard 120 mm width (internal) sizes (4, 6.3 and 6+6) and in two standard 60mm width (internal) sizes (1 and 5).
- ◆ Designed to be bolted inside or outside the electrical panel board/cabinet.
- ◆ Materials: Aluminium.
- ◆ IP66 and IP67 protection.
- ◆ To be sealed with Hawke DM series: DM tolerant and blank sealing modules, CSDM compression system and stayplates.

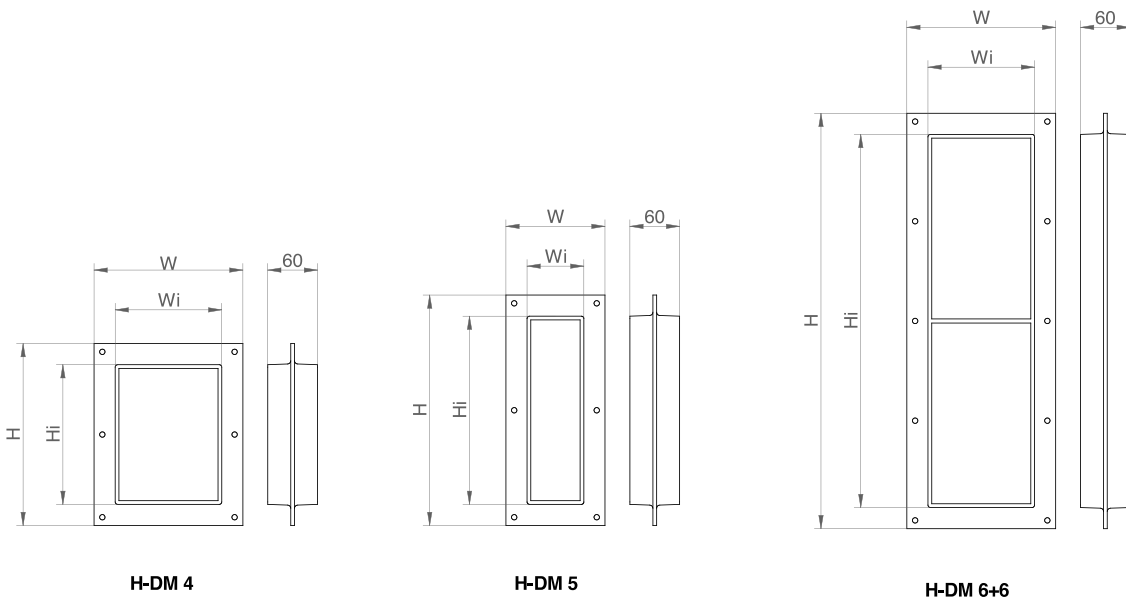

DESCRIPTION	EXTERNAL DIMENSIONS				Weight (kg)
	W (mm)	H (mm)	Wi (mm)	Hi (mm)	
H-DM 1	120	160	69	109	0,4
H-DM 4	180	220	129	169	0,7
H-DM 5	120	278	69	227	0,7
H-DM 6.3	180	300	129	249	0,9
H-DM 6+6	180	501	129	450	1,4

*All dimensions are nominal values

H-DM Frame

Sealing Area

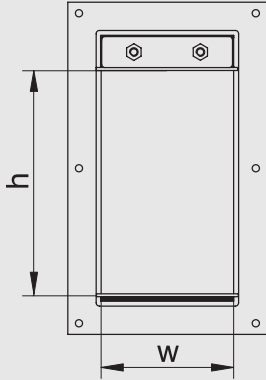

DESCRIPTION	SEALING AREA (mm)
H-DM 1	60x60
H-DM 4	120x120
H-DM 5	60x180
H-DM 6.3	120x200
H-DM 6+6	2x (120x180)

Hole dimension

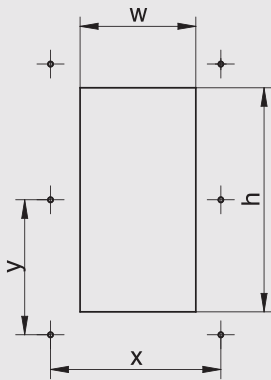

DESCRIPTION	HOLE DIMENSIONS		BOLTS POSITION		
	w (mm)	h (mm)	Φ (mm)	x (mm)	y (mm)
H-DM 1	77	117	6	100	140
H-DM 4	137	177	6	160	100
H-DM 5	77	235	6	100	126
H-DM 6.3	137	257	6	160	140
H-DM 6+6	137	458	6	160	120

*All dimensions are nominal values

Installation references

	page
See accessories	76
See installation guide	126

CSDM Compression Kit



Hawke CSDM Compression system is used in H-DM frames to compress and seal the installation of cables and DM modules. It includes the endpacker unit, 5mm filler strip and two stayplates. The 5mm filler strip can be installed as either the top or bottom row of blocks within a H-DM aperture.

The extra 5mm strip is recommended to be placed on the bottom row of the frame, along with one of the stayplates.

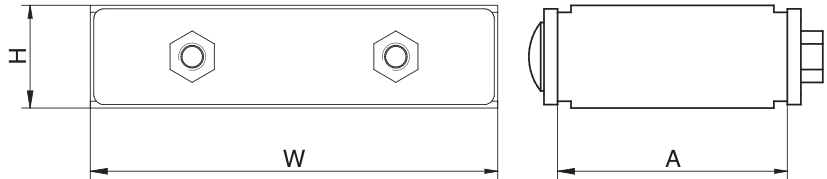

	DESCRIPTION	Qty	W [mm]	H [mm]	A [mm]	Weight (kg)
CSDM – 120/S Compression Kit	DM - Endpacker	1	120	30	68	0,6
	DM50	1	120	5	60	0,02
	Stayplate	2	-	-	-	-
CSDM – 60/S Compression Kit	DM - Endpacker 60mm	1	60	30	68	0,3
	DM50 60mm	1	60	5	60	0,01
	Stayplate 60mm	2	-	-	-	-

Installation Options

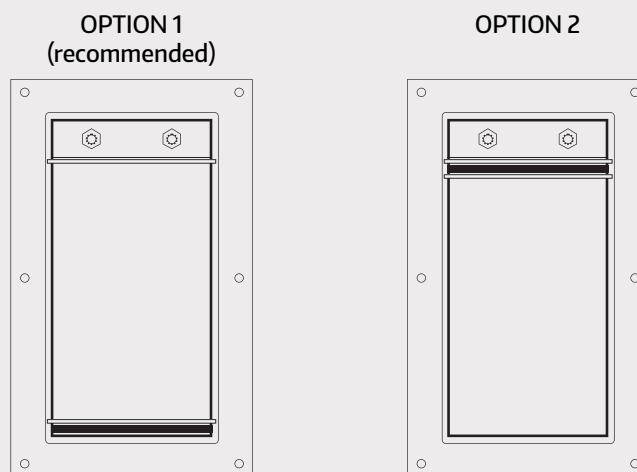

- ◆ **Option 1 (recommended):** Endpacker and stayplate located in upper end of the frame. Dm50 compensation module located on the bottom end, with a stayplate over it (never between module and frame).
- ◆ **Option 2:** Endpacker, DM50 compensation module and 2 stayplates located in the upper end of the frame. Each stayplate should be located in between the rubber components (endpacker-DM50 and DM50-inferior modules).

DM Tolerant blocks



Hawke DM tolerant blocks are designed to accommodate different cable sizes passing through the frame.

Like all Hawke modules, its degree of flexibility allows cable diameter variances and its colour-coding feature allows easy installation and onsite inspection.

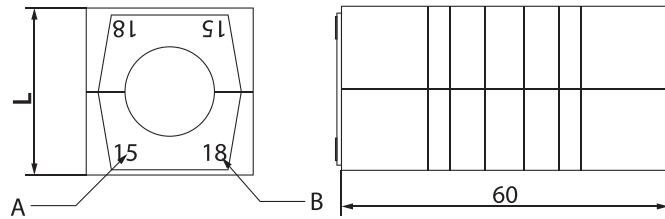

DESCRIPTION	L (mm)	CABLES DIAMETER		WEIGHT (kg)	COLOUR
		LABEL A	LABEL B		
		MINIMUM (mm)	MAXIMUM (mm)		
DM 153	15	3	5	0,01	Red
DM 155	15	5	7	0,01	White
DM 157	15	7	9	0,01	Blue
DM 203	20	3	6	0,02	Green
DM 206	20	6	9	0,02	Pink
DM 209	20	9	12	0,02	Brown
DM 2011	20	11	14	0,02	Yellow
DM 2013	20	13	16	0,02	Golden
DM 3012	30	12	15	0,04	Red
DM 3015	30	15	18	0,04	White
DM 3018	30	18	21	0,04	Blue
DM 3021	30	21	24	0,03	Orange
DM 4012	40	12	15	0,12	Green
DM 4015	40	15	18	0,09	Pink
DM 4022	40	22	25	0,08	Red
DM 4025	40	25	28	0,07	White
DM 4028	40	28	31	0,06	Blue
DM 4031	40	31	34	0,05	Orange
DM 6031	60	31	34	0,17	Red
DM 6034	60	34	37	0,17	White
DM 6037	60	37	40	0,16	Blue
DM 6040	60	40	43	0,15	Orange
DM 6043	60	43	46	0,14	Purple
DM 6046	60	46	49	0,13	Yellow
DM 6049	60	49	52	0,11	Green
DM 6052	60	52	54	0,09	Pink

DM

Blank blocks

Hawke DM blank modules are designed to fill spaces within the frame which are not required for services, thus allowing spare capacity for future requirements.

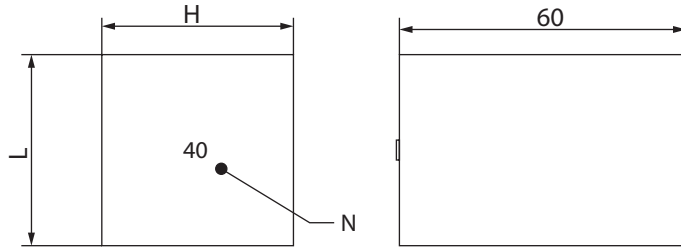

DESCRIPTION	L (mm)	H (mm)	LABEL (N)	WEIGHT (kg)	COLOUR
DM 150	15	15	15	0,01	Black
DM 200	20	20	20	0,02	
DM 300	30	30	30	0,06	
DM 400	40	40	40	0,11	
DM 600	60	60	60	0,22	
DM 50	5	120	-	0,02	
DM 100	10	120	-	0,08	

STAYPLATES

Stayplates ensure the blocks in a Hawke rectangular system (tolerant and blank ones) are fixed in position after compression.

A stayplate should be placed above each complete row of insert/filler blocks, also one stayplate should be installed below the HDM endpacker (already included in CSDM compression kit).

- ◆ Available in AISI 304 stainless steel. AISI 316 and other materials under request.

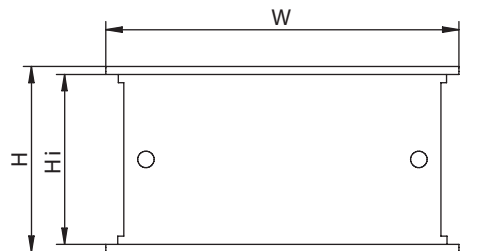

DESCRIPTION	W (mm)	H (mm)	Hi (mm)
Stayplate 931 60mm	68	68	62
Stayplate 931 120mm	128	68	62



EX
CERTIFICATES

EX HAWKE TRANSIT SYSTEM

An explosive atmosphere is defined as a mixture of dangerous substances with air, under atmospheric conditions, in the form of gases, vapours, mist or dust in which, after ignition has occurred, an explosion could take place.

Many industries may have activities that produce explosive or potentially explosive atmospheres, such as:

- ◆ Chemical plants
- ◆ Refineries and petrochemical plants
- ◆ Offshore platforms
- ◆ Mines
- ◆ Paint shops
- ◆ Waste recycling plants
- ◆ Wood transformation workshops
- ◆ Food industry and flour mills

Different international regulations were created to avoid or minimize the risks of an explosion, like International

IECEx directive, European **ATEX Workplace Directive** (Directive 99/92/EC) or European **ATEX Equipment**

Directive (Directive 94/9/EC), which implies all devices installed in a potential hazardous area.



These hazardous areas are classified according to the degree of risk of an explosion taking place, identifying if the risk comes from a flammable gas mixture or from dust.

Formation of ATEX	Duration of ATEX	Type of substances forming the ATEX	
		Gas, vapour or mist (Type I)	Flammable dust cloud (Type II)
Constant or very frequent	Prolonged time	Zone 0	Zone 20
Occasional	Occasional	Zone 1	Zone 21
Not probable	Short period of time	Zone 2	Zone 22

In every company, the plant manager is responsible for evaluating the risks present at the site, and the implementation of the appropriate equipment in each zone identified.

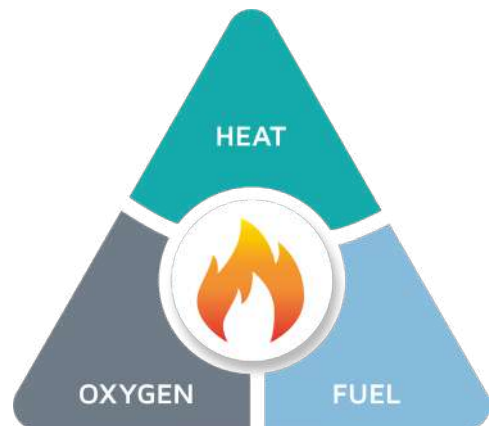

Hawke Transit System Ex products are design to be used as a cable penetration seal in Exe / Ex tb enclosures, motors, junction boxes, etc.

Hawke HF tolerant blocks are designed to accommodate cables/pipes passing through the frame.

Our special design incorporates five contact points which allows the blocks to accommodate a range of different diameters and accept variances in cable/pipe diameter. Each block that a sealing range of 3-4mm without the need for any onsite modifications.

Also, Hawke’s colour-coding system makes installation easier, faster and allows a visual inspection of the transit when complete, in order to guarantee safety in hazardous areas.

HTS combination of frames, blocks and accessories are certified according to ATEX and IECEx standards.

This includes rectangular and round marine and civil installations in standard HF version, but also guaranteeing EMI protection with HTS EMC Ex systems.

REF

- ◆ Marine rectangular frames16
- ◆ Civil rectangular frames38
- ◆ Round transits50
- ◆ Blocks68
- ◆ Accessories76

All HTS Ex products are identified with Ex labels.

For more information about HTS Ex products, please contact sales department.

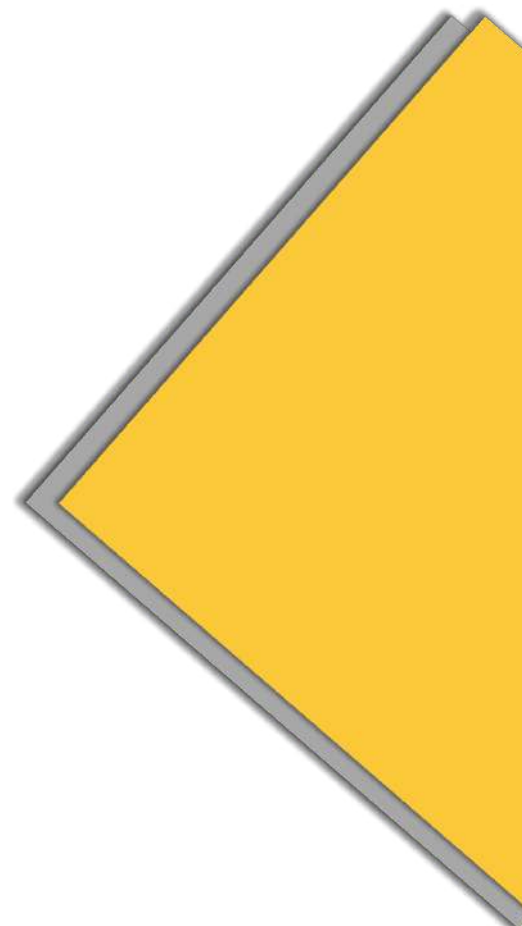

HMS Hawke Management Software

Hawke Management Software makes easier and faster the design of your cable transit projects, calculating material list and distribution automatically, while maintaining traceability of all the cable data, percentages of saturation per area, etc.

With HMS is possible to import project and cable data from an extern file, managing thousands of cables and transits in few clicks and obtaining material lists, detailed transit drawings and different kind of project and transit reports.

The software allows to modify data and do the recalculation automatically, always giving best combination of frames and blocks in order to save money and time.

Installation drawings and cable layouts facilitates the installation showing the colour coded blocks, helping to save much time and maintaining traceability of the transits.

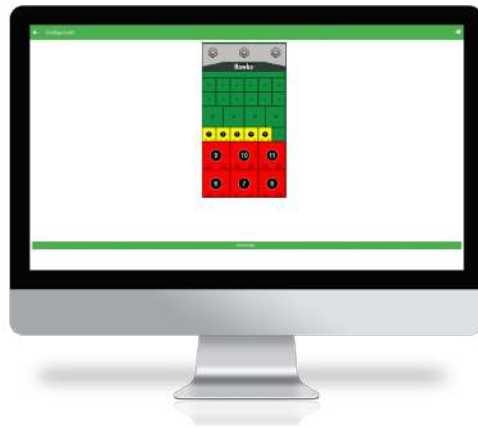

CHARACTERISTICS

- ◆ Save time designing your projects.
- ◆ Manage big amount of cables and transits.
- ◆ Import cable schedule and project data.
- ◆ Calculate automatically or manually the best combination of materials.
- ◆ Export material list, reports and installation drawings.
- ◆ Modify cables position directly on the drawing.
- ◆ Preview the transit with colour coded blocks.
- ◆ Export a project summary for requesting a quotation quickly.
- ◆ Share the projects through internal server.



APP Hawke Transit Installers App



Hawke Installers App makes it easier and faster to carry out the installation of your transit installations.

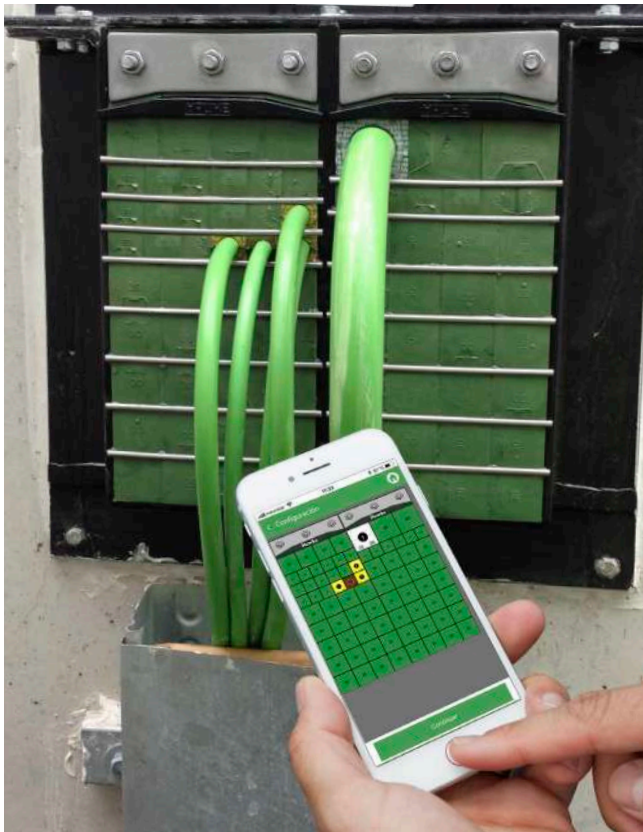

Designed to be launched from a portable device iOS or Android (smartphone or tablet). The Installer's App allows the installer to calculate automatically the best configuration for a transit, it exports the material list, drawings with colour-coding and other important information.

Also, the installer can consult product information, installation instructions/tips, watch the installation videos and contact Hawke Transit System for technical support. All of these features help to reduce installation time and avoid potential installation mistakes.

CHARACTERISTICS

- ◆ Save time installing your projects.
- ◆ Calculate automatically or manually the best combination of materials.
- ◆ Modify and adapt configurations manually.
- ◆ Export material list, reports and installation drawings.
- ◆ Modify cables positions directly on the drawing.
- ◆ Preview the transit with colour coded blocks.
- ◆ Export a project summary for requesting a quotation quickly.



TECHNICAL SUPPORT SERVICE

TRAINING

Hawke offers a complete Installation Training program for your installers. The Installation Training also enables your installers to learn the best installation techniques thus saving time and preventing installation mistakes.

The training also demonstrates that **Hawke can be installed much faster** than other transit systems.

This training can include inspection and supervision support in order to detect possible installation mistakes and propose necessary correct actions.



TECHNICAL SUPPORT SERVICE

TRAINING CENTRE

To support everyone in gaining the skills needed to put safety first when installing cable and pipe transits from Hawke, we have designed a straightforward self-education program.

We train our clients in our specific Training Centre to expand your knowledge, sharpen your competitive edge and **save on production time.**

The Hawke Training Centre has all of the necessary equipment needed to ensure that a high level of training is met, in accordance with the requirements of the projects in which our products will be installed.

Hawke's training team is made up of qualified technicians with more than 20 years of experience in installing the Hawke Transit System.



Installation guide:



Lubricate the inside of the frame. Ensure the corners are well lubricated.



Take measures of the cables diameters and select the appropriate Hawke Tolerant blocks. Colour code will help you to select the correct ones.

INSTALLATION GUIDE

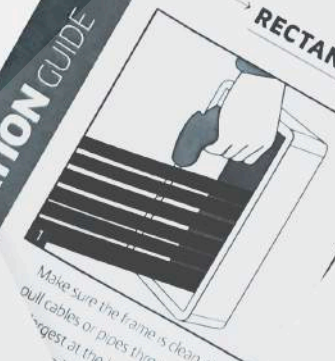

Make sure the frame is clean, then pull cables or pipes through, placing largest at the bottom. (Note: Use Tolerant blocks to fit around cables/pipes)

RECTANGULAR SYSTEM standard installation guide:



Make a visual inspection of the transit HRST (colour code) selected match the pipe and sleeve installed. HRST is completely inserted into the sleeve. It does not exist gaps between HRST and the cable/pipe.

INSTALLATION

DESCRIPTION	SLEEVE SIZE NEEDED
HRST-30/4/IES	30
HRST-30/7/IES	30
HRST-30/10/IES	30
HRST-40/4/IES	40
HRST-40/7/IES	40
HRST-40/10/IES	40

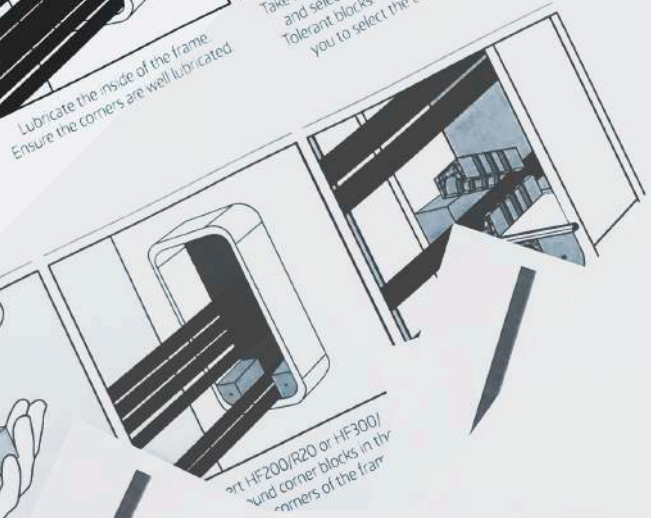

Lubricate the corner blocks in the corners of the frame.

00-07/18

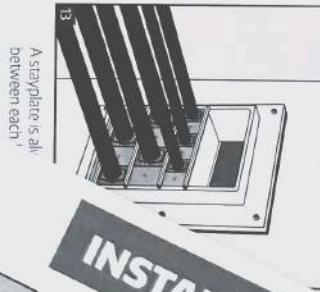
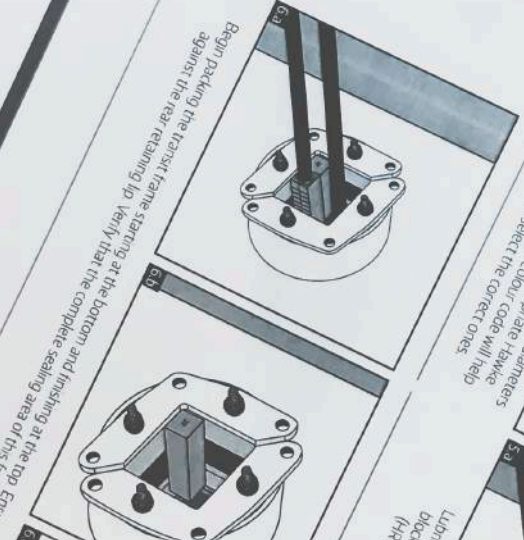

Assemble is all between each!

Take measures of the cables diameter with a caliper and select the appropriate Hawke Tolerant blocks. Color code will help you to select the correct ones. Only use H-DMA black blocks.

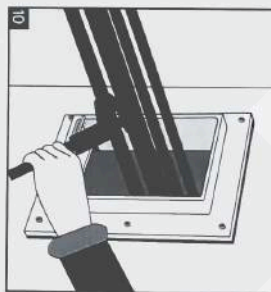

Lub

INSTALLATION GUIDE

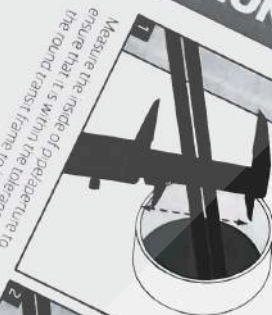

Measure the inside of the HRST to ensure that it is within the tolerance of the round transit frame to be used.

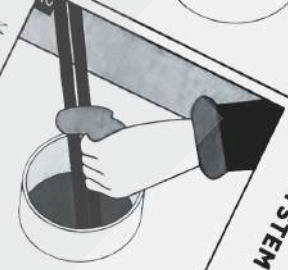

Make sure the frame is clean

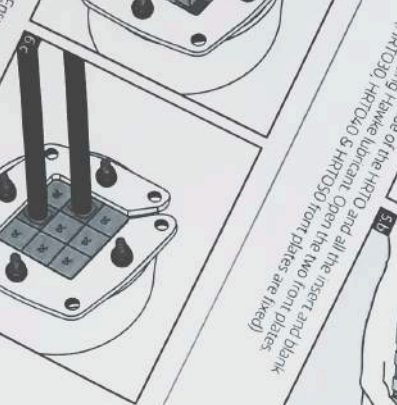

Lubricate the inside of the HRST and all the insert and blank blocks using Hawke Lubricant. Open the two front plates (HRST0, HRST1, HRST2, HRST3, HRST4, HRST5 front plates are fixed).

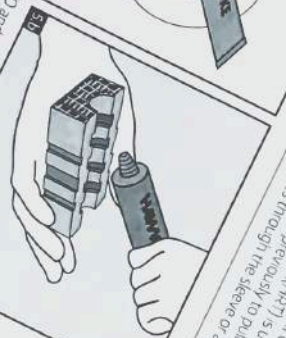

Insert the round transit frame completely into the sleeve. The sleeve aperture around the HRST should be applied to the HRST. If (close version) be installed previously, it should be installed through the sleeve or aperture.

HRT0 / HRT ROUND SYSTEM standard installation

INSTALLATION GUIDE

INSTALLATION GUIDES..... 115

RECTANGULAR SYSTEM..... 116

HMCX SYSTEM 118

HRTO/HRT ROUND SYSTEM120

HRST ROUND SYSTEM.....122

HRST MULTIHOLE ROUND SYSTEM 124

H-DM CABINET SEAL SYSTEM.....126

RECTANGULAR EMC SYSTEM.....129

HMCX EMC SYSTEM 132

HRTO/HRT EMC ROUND SYSTEM135

COMPRESSION TOOL138

PULLER139

CLAMP TOOL140

RECTANGULAR CIVIL FRAMES INSTALLATION GUIDES 141

CIVIL SLEEVES INSTALLATION GUIDE..... 146

WELDING INSTALLATION GUIDES 150

STANDARD WELDING INSTRUCTIONS.....150

SLEEVES WELDING INSTRUCTIONS..... 152

HMFx WELDING INSTRUCTIONS..... 154

HMOX 156

INSTALLATION AND INSPECTION CHECKS GUIDELINES:..... 158

RECTANGULAR STANDARD ..158

ROUND HRTO/HRT 160

ROUND HRST STANDARD162

ROUND HRST MULTIHOLE....163

TEMPLATES165

MARINE AND CIVIL RECTANGULAR STANDARD166

ROUND CORNERS HMCX 167

CABINET SEAL H-DM168

ROUND TRANSITS HRTO169

INSTALLATION GUIDES INDEX

→ **RECTANGULAR SYSTEM** standard installation guide:

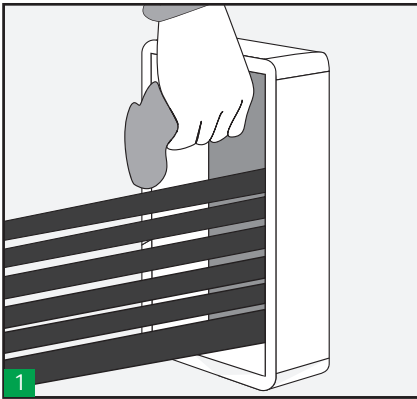

1 Make sure the frame is clean, then pull cables or pipes through, placing the largest at the bottom. (Note: Use open ended frame to fit around existing cables/pipes)

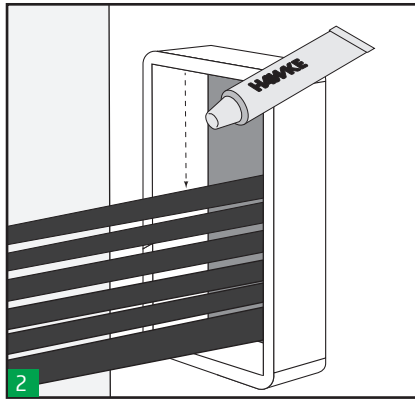

2 Lubricate the inside of the frame. Ensure the corners are well lubricated.

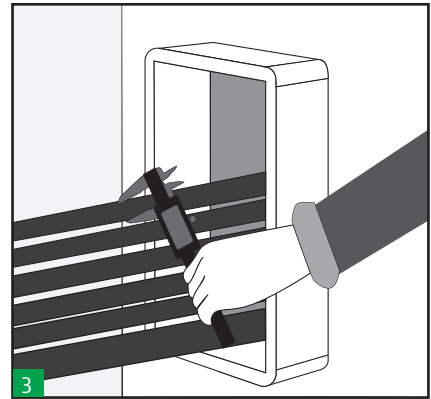

3 Take measures of the cables diameters and select the appropriate Hawke Tolerant blocks. Colour code will help you to select the correct ones.

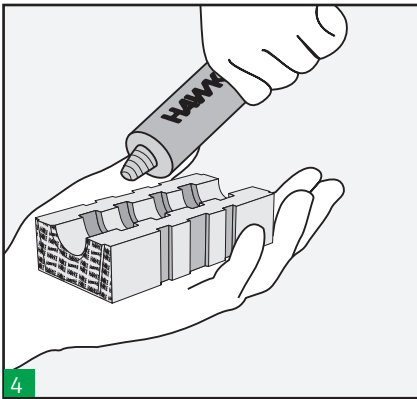

4 Lubricate all the insert and blank blocks using Hawke lubricant.

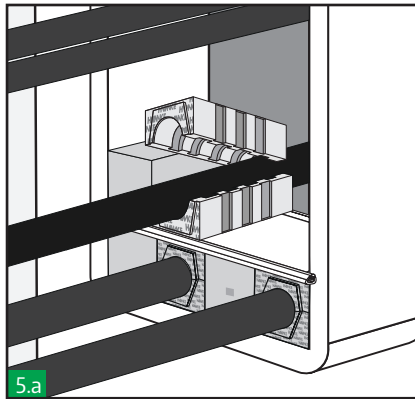

5.a

Begin packing the frame. Colour code will help you to install the blocks correctly. A stayplate is always inserted between each layer of blocks. Blocks should not protrude out of the stayplates retaining lips.

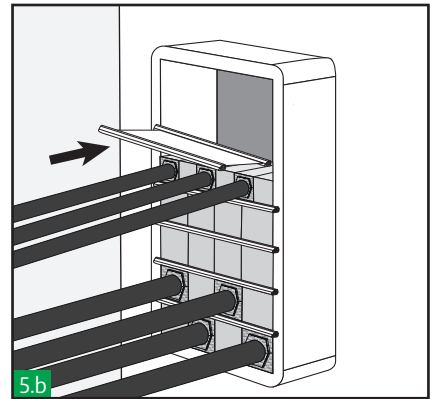

5.b

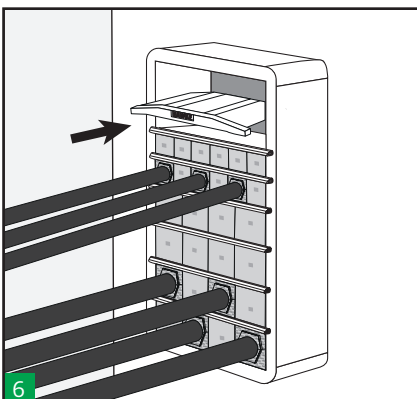

6

Insert the last stayplate and the compression plate before the last row of blocks (or earlier if required). Check frame packing space. Verify that the complete sealing area of this frame size (see table) will be filled with blocks.

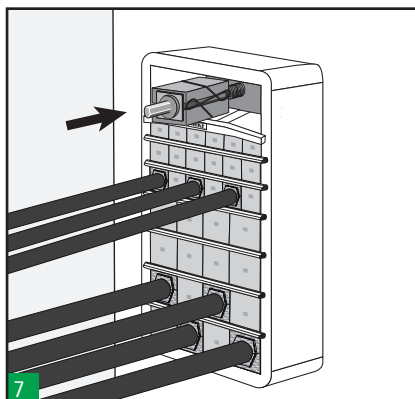

7

Pack the last row between the last stayplate and the compression plate. Insert the compression tool on the top, in the centre of the compression plate.

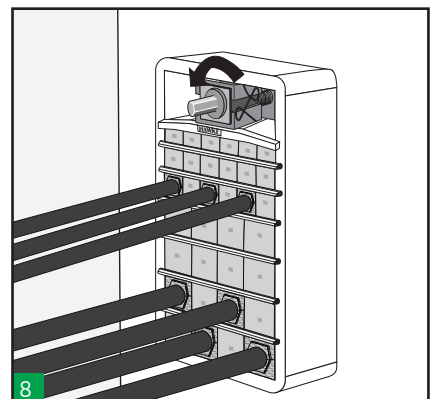

8

Tighten the compression tool until there is sufficient room to fit the outer blocks of the endpacker.

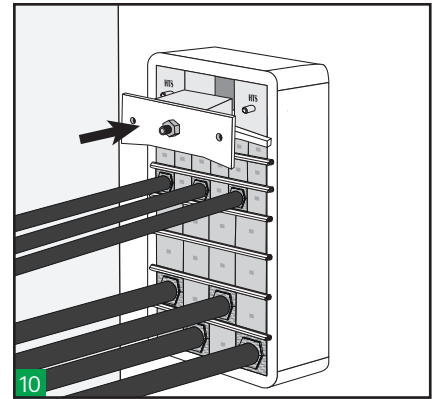
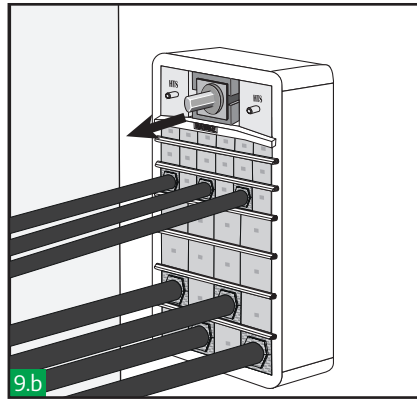
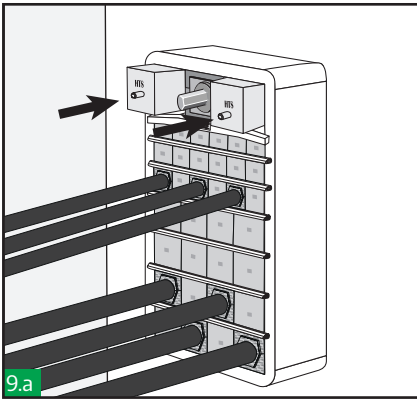

Insert the outer blocks of the endpacker. Then, untighten the compression tool and remove it.

Insert the centre piece of the endpacker along with the front plate.

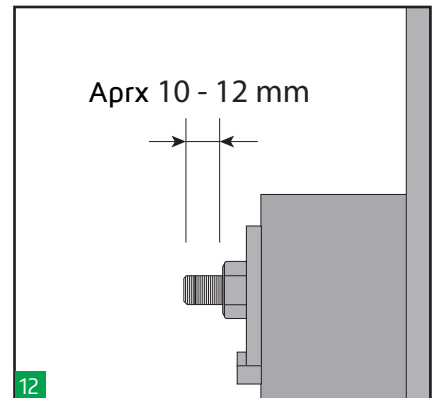
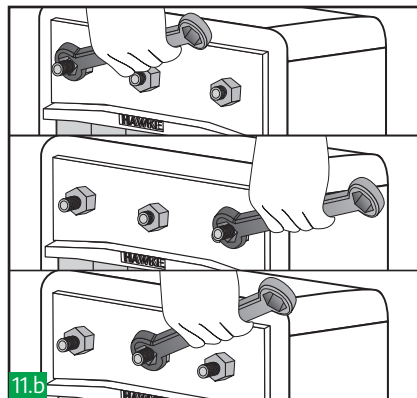
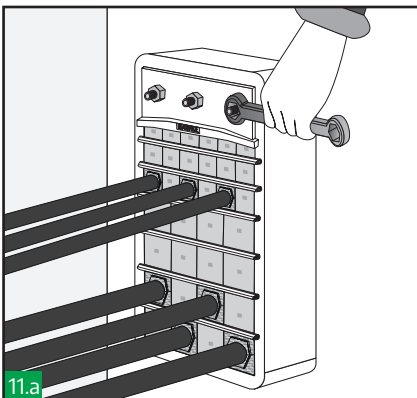

Tighten the nuts on the endpacking alternately following the above sequence to compress and complete the seal. Use a ratchet spanner for an easier installation.

Approximately 10-12 mm of thread should protrude on each bolt to ensure the sealing.

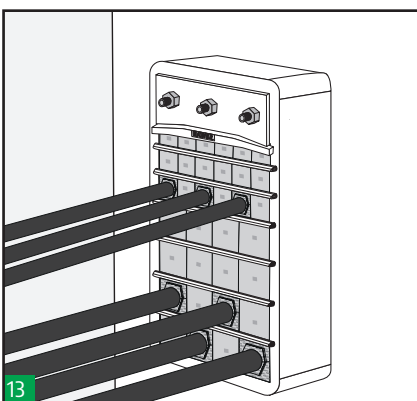

Make a visual inspection of the transit. Hawke's unique colour coding system enables the installation to be visually inspected after completion and ensures correct matching of the block halves.

Notes
 Leave the system at least 24 hours before applying pressure. For disassembly see disassembly instructions.

Sealing Area

APERTURE SIZE	SEALING AREA (w x h)
1	60 x 60
2	120 x 60
3	60 x 120
4	120 x 120
5	60 x 180
6	120 x 180
7	60 x 240
8	120 x 240

HTS-EN-A1001-Rev04-12/21

HMCX SYSTEM standard installation guide:

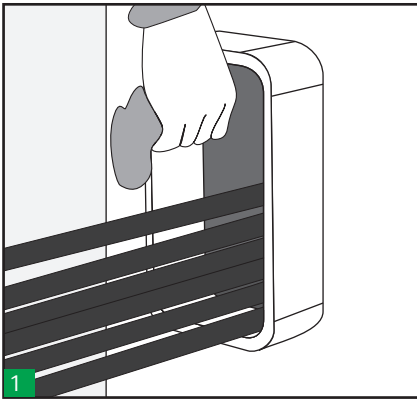

1 Make sure the frame is clean, then pull cables or pipes through, placing the largest at the bottom.
(Note: Use open ended frame to fit around existing cables/pipes)

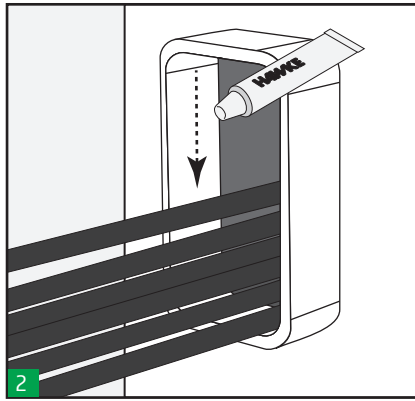

2 Lubricate the inside of the frame. Ensure the corners are well lubricated.

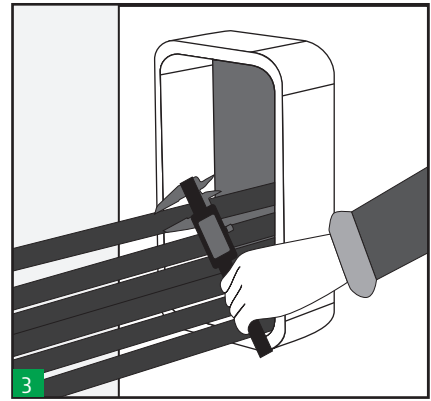

3 Take measures of the cables diameters and select the appropriate Hawke Tolerant blocks. Colour code will help you to select the correct ones.

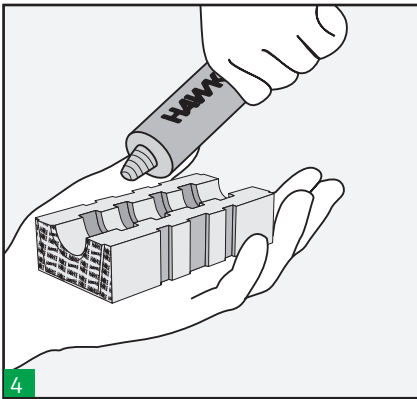

4 Lubricate all the insert and blank blocks using Hawke lubricant.

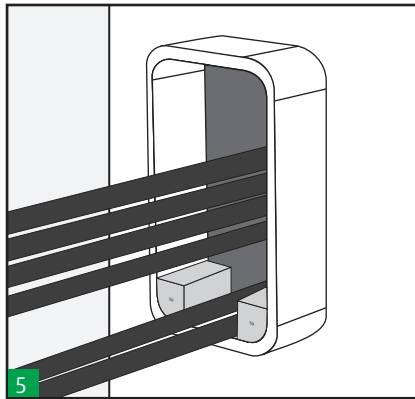

5 Insert HF200/R20 or HF300/R20 round corner blocks in the bottom corners of the frame.

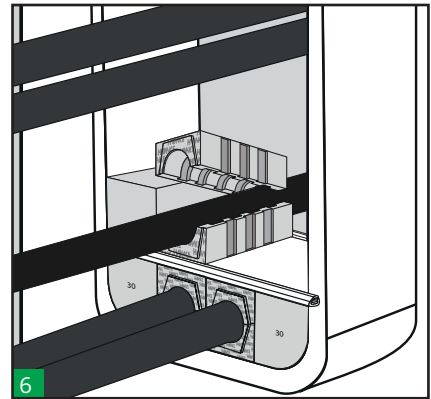

6 Begin packing the frame. Colour code will help you to install the blocks correctly.

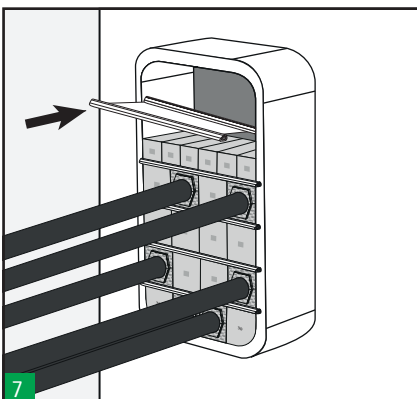

7 A stayplate is always inserted between each layer of blocks. Blocks should not protrude out of the stayplates retaining lips.

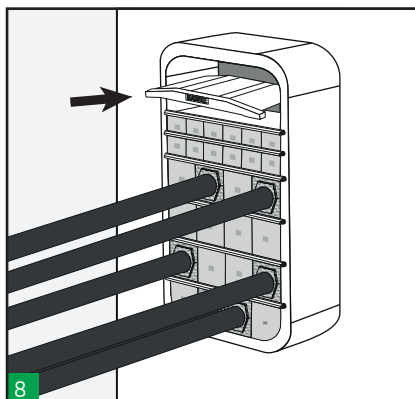

8 Insert the last stayplate and the compression plate before the last row of blocks (or earlier if required). Check frame packing space. Verify that the complete sealing area of this frame size (see table) will be filled with blocks.

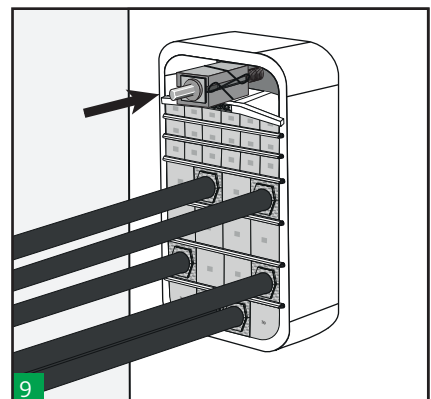

9 Pack the last row between the last stayplate and the compression plate. Insert the compression tool on the top, in the centre of the compression plate.

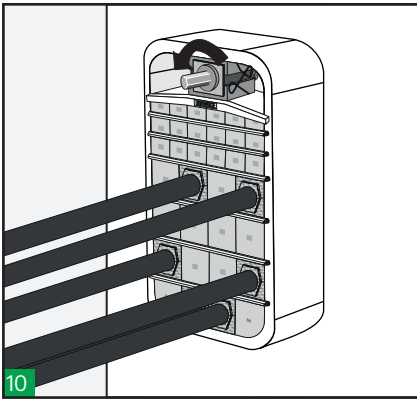

Tighten the compression tool until there is sufficient room to fit the outer blocks of the endpacker.

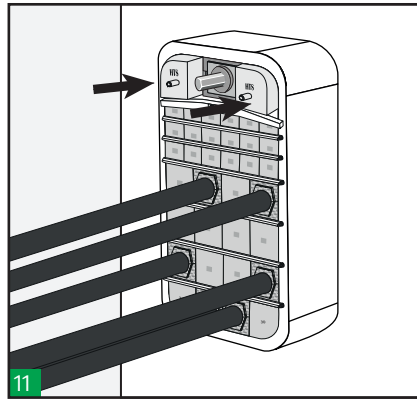

Insert the outer blocks of the endpacker. Then, untighten the compression tool and remove it.

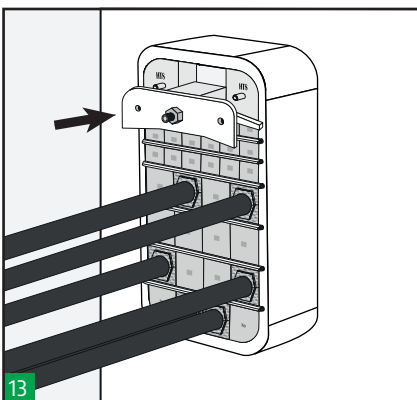
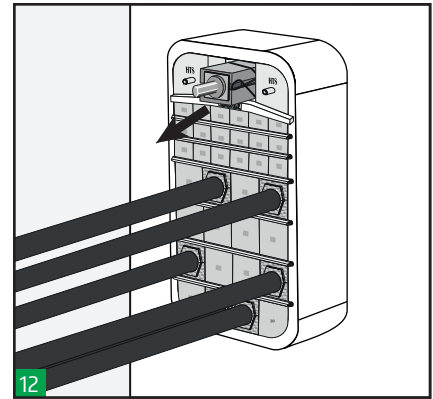

Insert the centre piece of the endpacker along with the front plate.

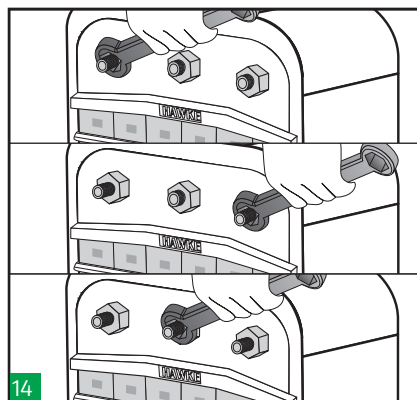

Tighten the nuts on the endpacking alternately following the above sequence to compress and complete the seal. Use a ratchet spanner for an easier installation.

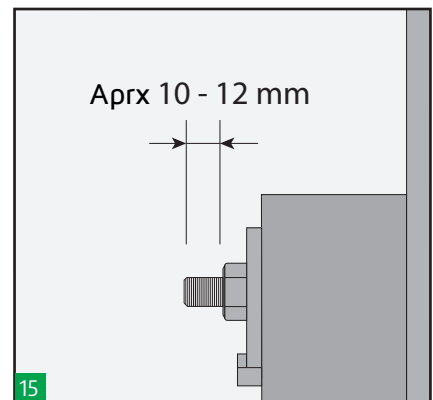

Approximately 10-12 mm of thread should protrude on each bolt to ensure the sealing.

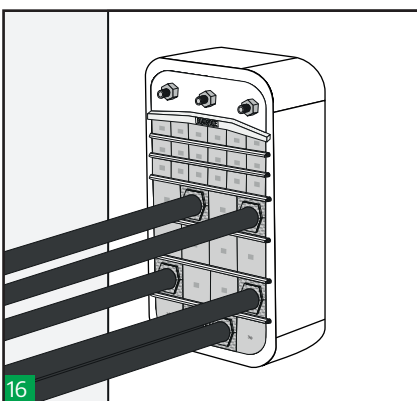

Make a visual inspection of the transit. Hawke's unique colour coding system enables the installation to be visually inspected after completion and ensures correct matching of the block halves.

◆ Notes

Leave the system at least 24 hours before applying pressure. For disassembly see disassembly instructions.

◆ Sealing Area

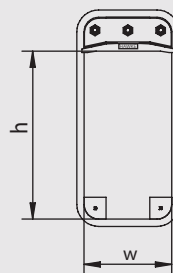

SIZE	SEALING AREA (w x h)
2	120x60
4	120x120
6	120x180
8	120x240

→ **HRTO / HRT ROUND SYSTEM** standard installation guide:

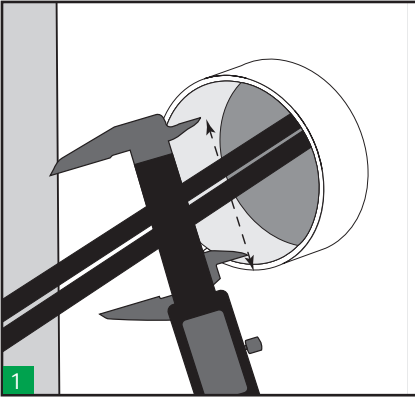

1 Measure the inside of pipe/aperture to ensure that it is within the tolerance of the round transit frame to be used.

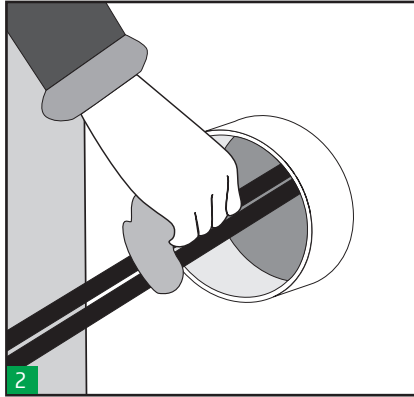

2 Make sure the frame is clean

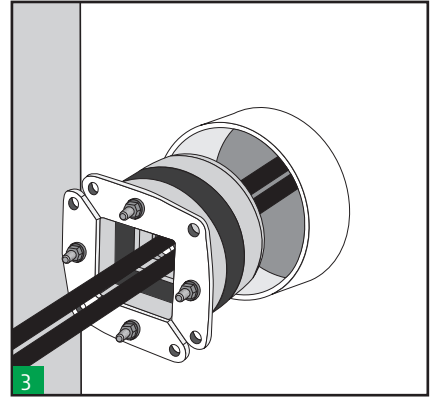

3 Insert the round transit frame completely in the sleeve/aperture around the cables. No lubricant should be applied to the aperture or outside of the frame. If close version of the Round Transit(HRT) is used, it should be installed previously to pull the cables/ pipes through the sleeve or aperture.

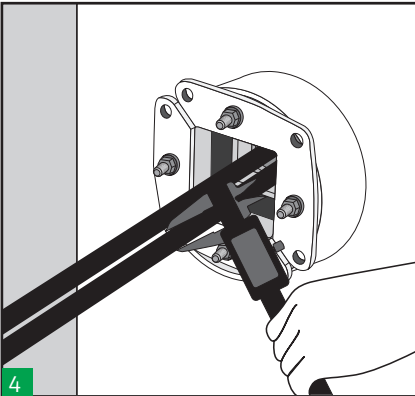

4 Take measures of the cables diameters and select the appropriate Hawke Tolerant blocks. Colour code will help you to select the correct ones.

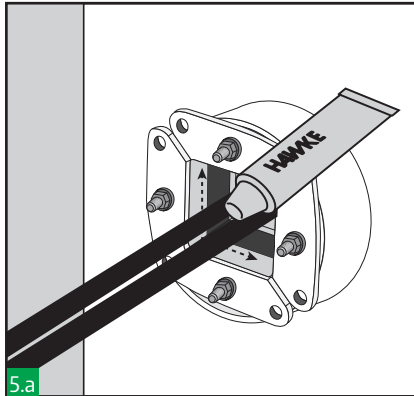

5.a Lubricate the inside of the HRTO and all the insert and blank blocks using Hawke lubricant. Open the two front plates. (HRTO30, HRTO40 & HRTO50 front plates are fixed)

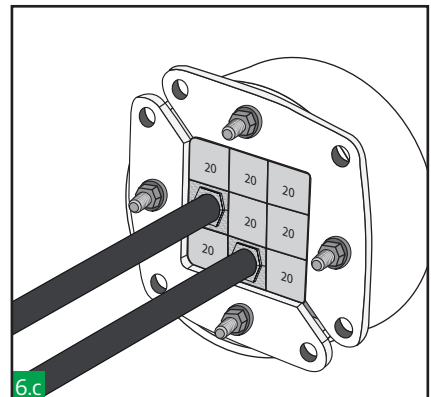
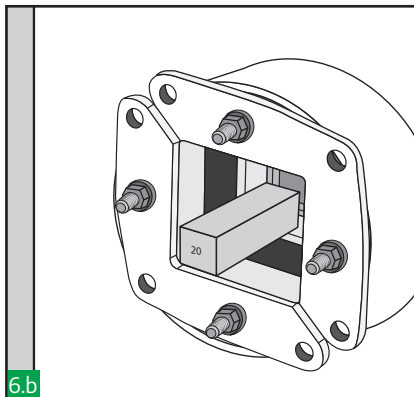
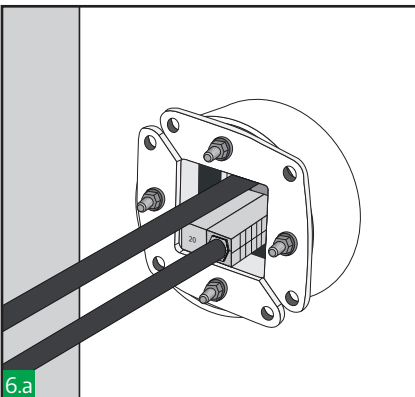
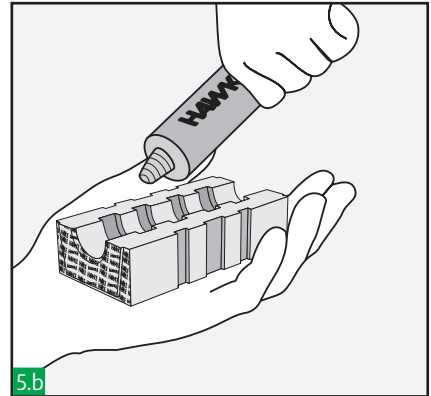

Begin packing the transit frame starting at the bottom and finishing at the top. Ensure that the blocks are pushed firmly against the rear retaining lip. Verify that the complete sealing area of this frame size (see table) is filled with blocks.

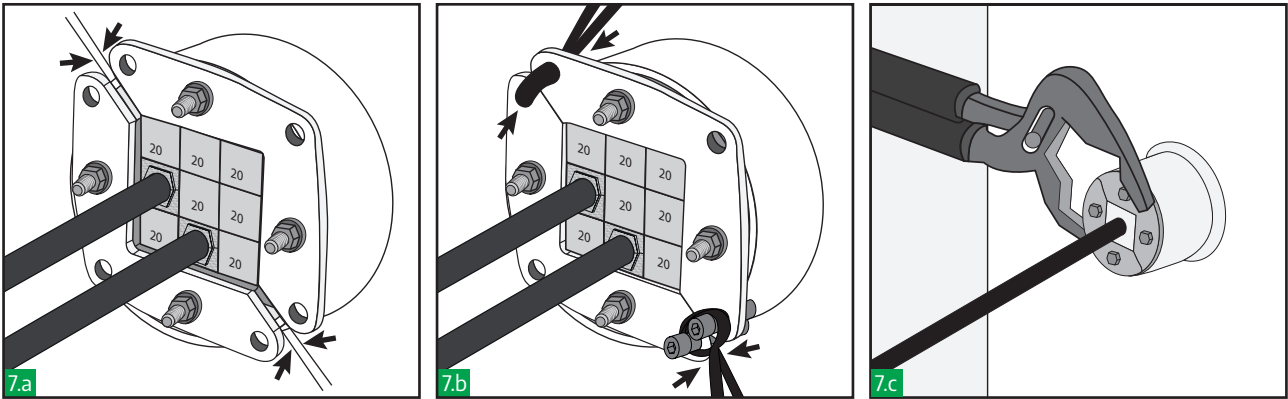

Slide the two front plates together and keep it fixed. Ensure all the blocks are located inside the front retaining lip. For an easier installation, cable ties, bolts or adjustable pliers can be used to close this plates.

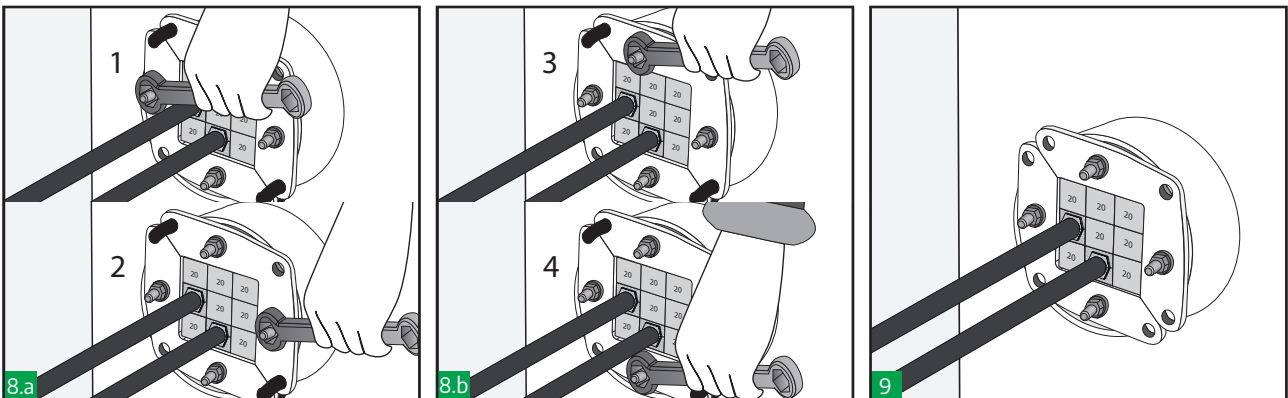

Tighten the nuts approximately 2mm each time following alternate tightening sequence, applying equal pressure to both plates. A minimum of 10 mm of thread should protrude on each bolt. Use a ratchet spanner for an easier installation.

Make a visual inspection of the transit. Hawke's unique colour coding system enables the installation to be visually inspected after completion and ensures correct matching of the block halves.

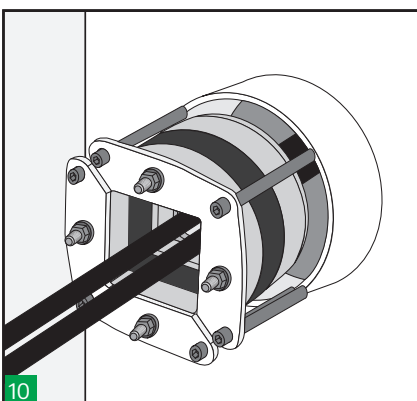

Extraction is achieved by releasing the compression, i.e. by reversing steps 7 and 8 and screwing M8 bolts (not supplied) into the threaded holes at each corner of the front plates. These releases the assembly from the aperture and allows the system to be disassembled.

◆ Notes

Leave the system at least 24 hours before applying pressure. For disassembly see disassembly instructions.

◆ Sealing Area

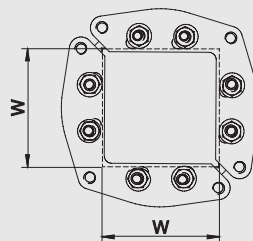

TYPE	SEALING AREA (mm)
HRTO-30	15x15
HRTO-40	20x20
HRTO-50	30x30
HRTO-70	40x40
HRTO-100	60x60
HRTO-125	80x80
HRTO-150	90x90
HRTO-200	120x120

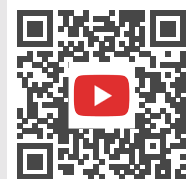

→ **HRST ROUND SYSTEM** standard installation guide:

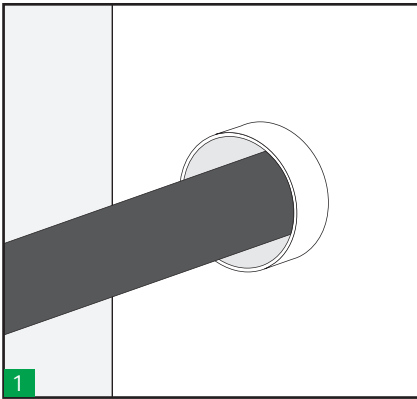

Check the inside diameter of the sleeve and the outside diameter of the cable/pipe to verify that it is within the range of selected HRST. Hawke HRST colour code will help for a correct selection.

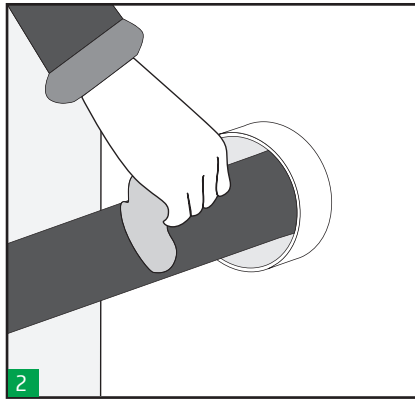

Make sure the pipe is properly centred in the sleeve. Make sure the sleeve and the cable/pipe are clean.

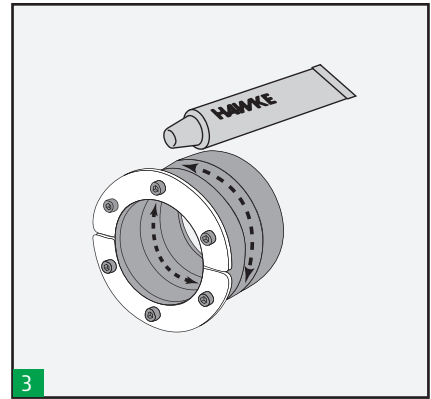

Lubricate the inside of the HRST to be in contact with the cable/ pipe and lightly lubricate the outside in contact with the sleeve.

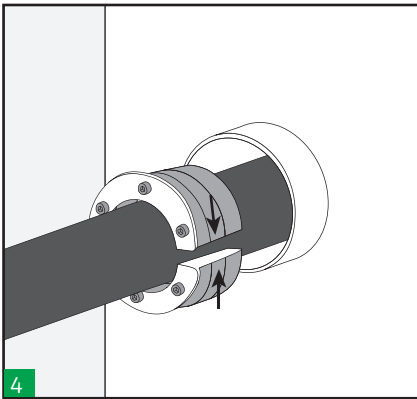

Open the HRST and install around the cable/pipe.

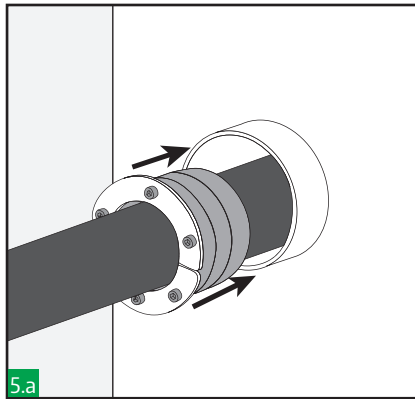

Insert the HRST into the sleeve. Check the HRST is completely inserted into the sleeve, front plates should be in contact with the sleeve.

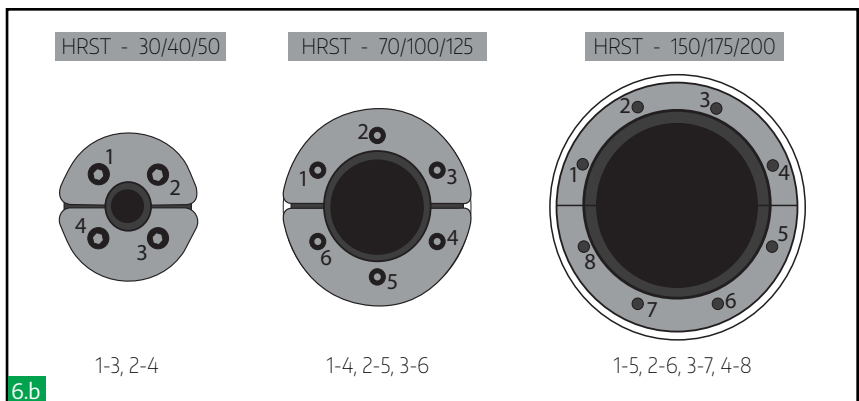
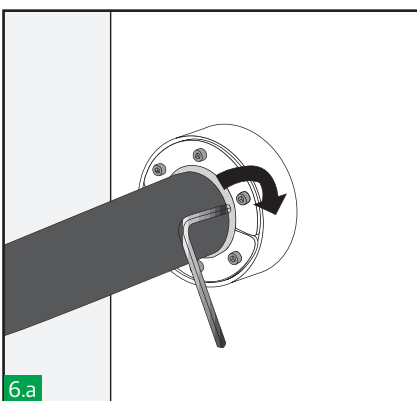
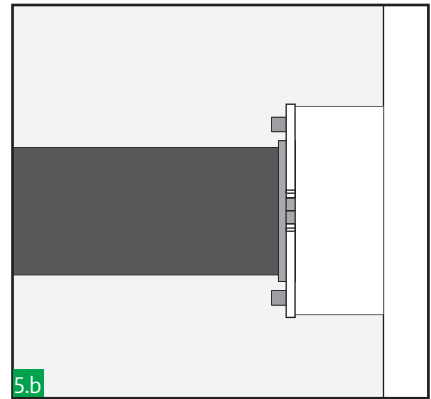

Tighten the bolts. Tightening must be done in one revolution step for each bolt following next sequence until the system is enough compressed to seal the cable/pipe.

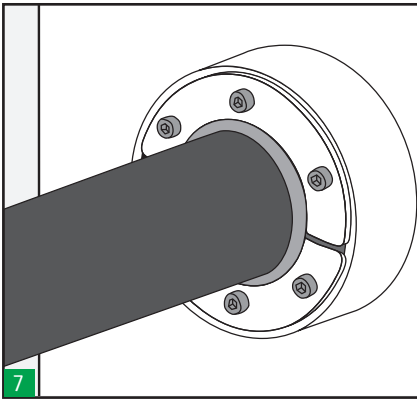

Make a visual inspection of the transit. HRST (colour code) selected match the pipe and sleeve installed, HRST is completely inserted into the sleeve, does not exist gaps between HRST and the cable/pipe.

DESCRIPTION	SLEEVE SIZE NEEDED	SEALING FROM (mm)	SEALING TO (mm)	COLOUR
HRST-30/4	30	4	10	White
HRST-30/7	30	7	14	Red
HRST-30/10	30	10	17	Blue
HRST-40/4	40	4	10	Purple
HRST-40/7	40	7	14	Yellow
HRST-40/10	40	10	17	Green
HRST-40/17	40	17	24	Pink
HRST-50/4	50	4	10	Red
HRST-50/10	50	10	17	White
HRST-50/17	50	17	24	Blue
HRST-50/24	50	24	30	Orange
HRST-70/26	70	26	33	Purple
HRST-70/33	70	33	39	Yellow
HRST-70/39	70	39	45	Green
HRST-70/45	70	45	50	Pink
HRST-100/48	100	48	55	Red
HRST-100/55	100	55	61	White
HRST-100/61	100	61	66	Blue
HRST-100/66	100	66	71	Orange
HRST-125/64	125	64	71	Purple
HRST-125/71	125	71	79	Yellow
HRST-125/79	125	79	86	Green
HRST-125/86	125	86	93	Pink
HRST-125/93	125	93	98	Orange
HRST-150/93	150	93	102	Red
HRST-150/102	150	102	108	White
HRST-150/108	150	108	115	Blue
HRST-150/115	150	115	120	Orange
HRST-175/118	175	118	125	Purple
HRST-175/125	175	125	132	Yellow
HRST-175/132	175	132	138	Green
HRST-175/138	175	138	145	Pink
HRST-200/136	200	136	143	Red
HRST-200/143	200	143	150	White
HRST-200/150	200	150	157	Blue
HRST-200/157	200	157	164	Orange
HRST-200/164	200	164	170	Yellow

*All dimensions are nominal values

◆ Notes
Leave the system at least 24 hours before applying pressure.

◆ Sealing Range
Check cable/pipe sealing range in HRST catalogue page 53.

→ **HRST MULTIHOLE ROUND SYSTEM** standard installation guide:

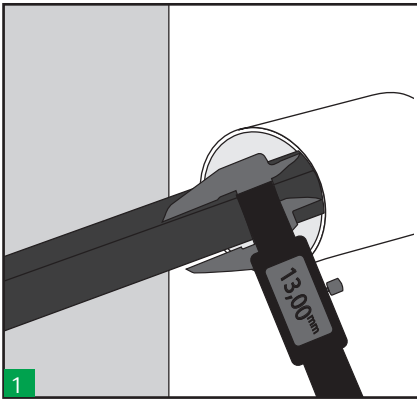

1 Check the inside diameter of the sleeve and the outside diameter of the cables to verify that it is within the range of selected HRST.

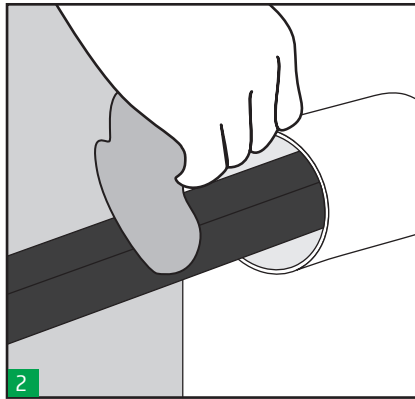

2 Make sure the sleeve and the cables are clean.

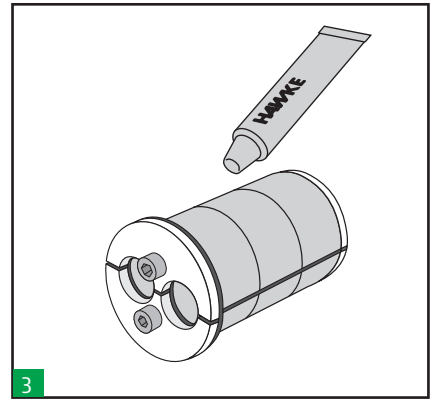

3 Lubricate the inside of the HRST to be in contact with the cables and lightly lubricate the outside in contact with the sleeve.

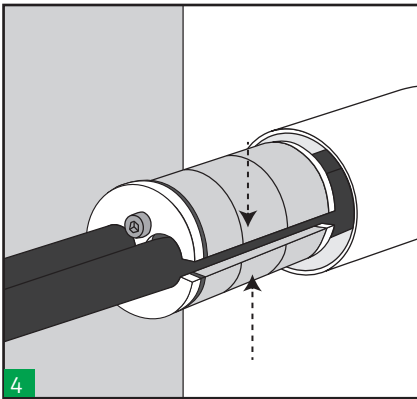

4 Open the HRST and install around the cables.

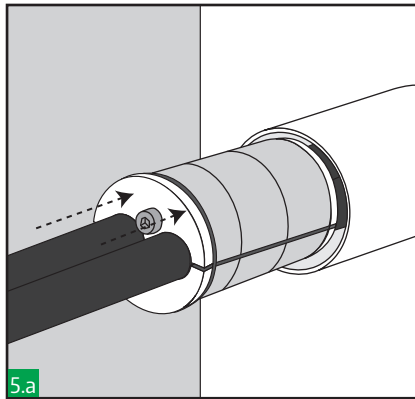

5.a

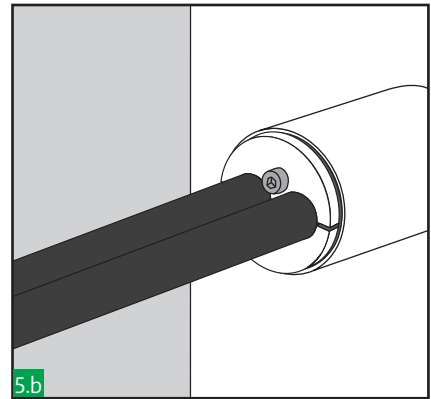

5.b

Insert the HRST into the sleeve. Check the HRST is completely inserted into the sleeve, front plates should be in contact with the sleeve.

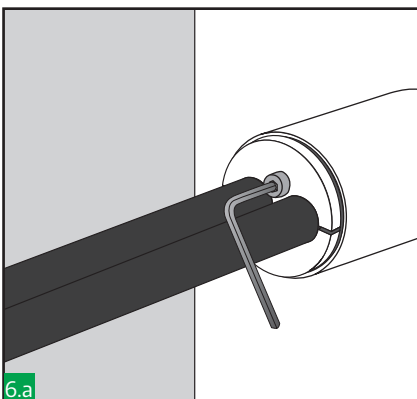

6.a

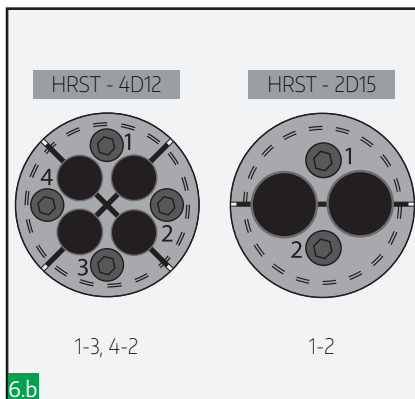

6.b

Tighten the bolts. Tightening must be done in one revolution step for each bolt following next sequence until the system is enough compressed to seal the cables.

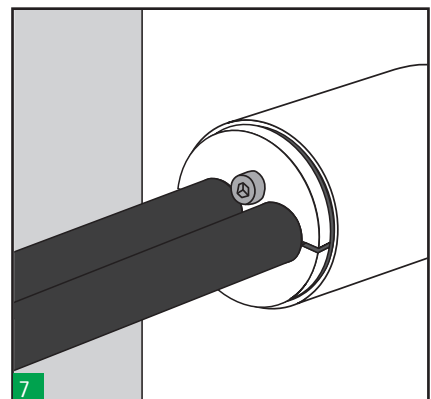

7

Make a visual inspection of the transit. HRST selected match the cables and sleeve installed, HRST is completely inserted into the sleeve, does not exist gaps between HRST and the cable/pipe.

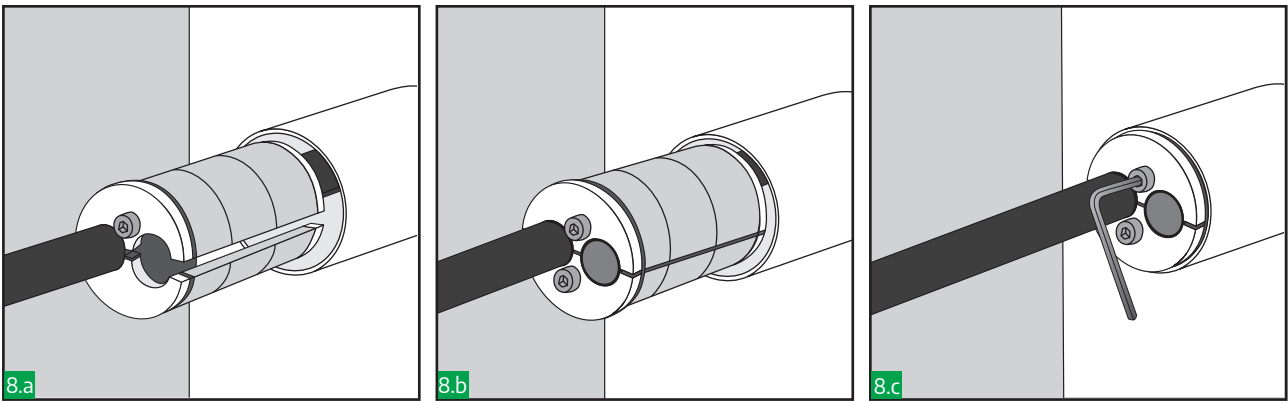

In case of any HRST hole are not occupied by cables always complete with Hawke HRST plugs.

DESCRIPTION	SLEEVE SIZE NEEDED	NUMBER OF CABLES	SEALING FROM (mm)	SEALING TO (mm)	A (mm)	B (mm)	NUMBER OF BOLT	BOLT SIZE	WEIGHT (kg)
HRST 40 2D15	40	2	10	15	40	46	2	M5	0,17
HRST 40 4D12	40	4	8	12	40	46	4	M5	0,16

◆ → **Notes**
 Leave the system at least 24 hours before applying pressure.

◆ → **Sealing Range**
 Check cable/pipe sealing range in HRST catalogue page 54.

→ **H-DM CABINET SEAL SYSTEM** standard installation.

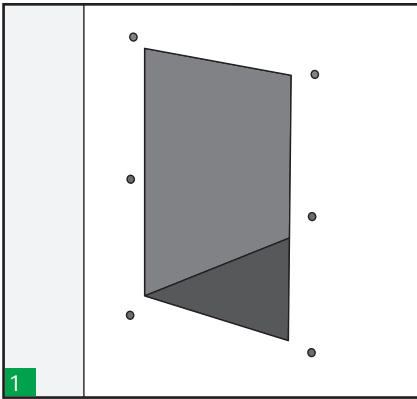

1 Cut a rectangular opening for the frame according to H-DH frame size to be used.(See table).

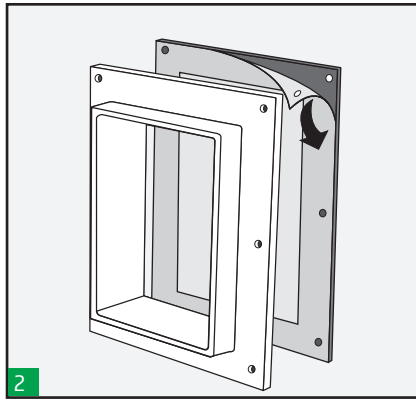

2 Remove the protection and stick the gasket on the aluminium frame.

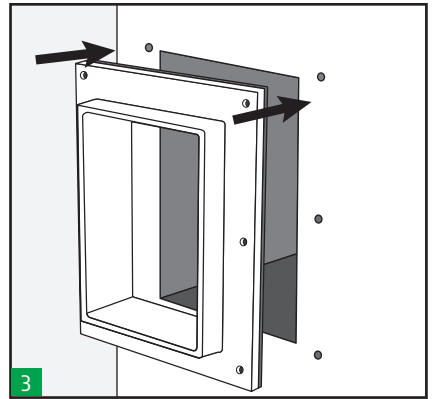

3 Install the frame in the opening with the gasket side towards the enclosure.

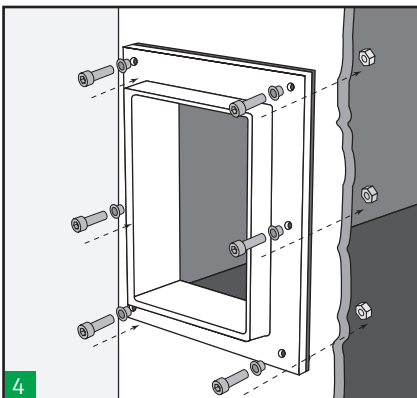

4 Insert bolts washers and nuts to the frame/ enclosure.

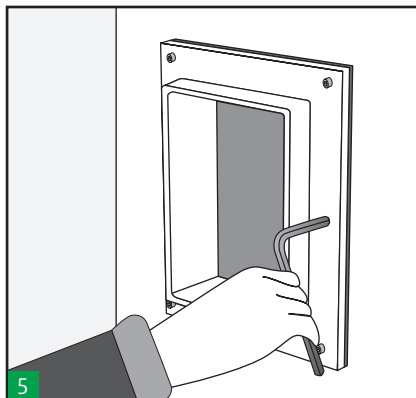

5 Screw the frame to the cabinet.

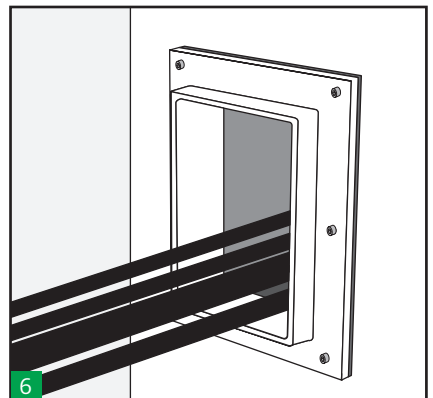

6 Pull cables or pipes through, placing the largest at the bottom.

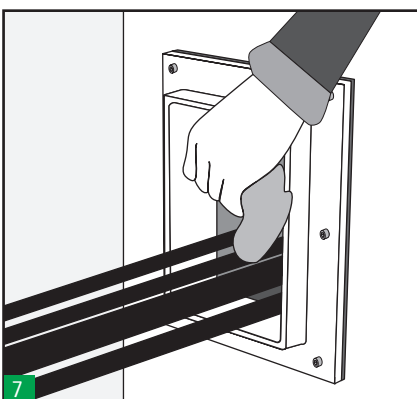

7 Make sure the frame is clean.

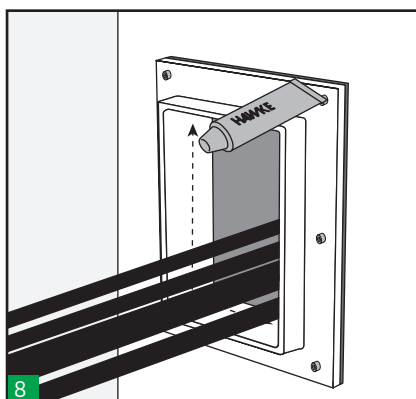

8 Lubricate the inside of the frame. Make sure the corners are well lubricated.

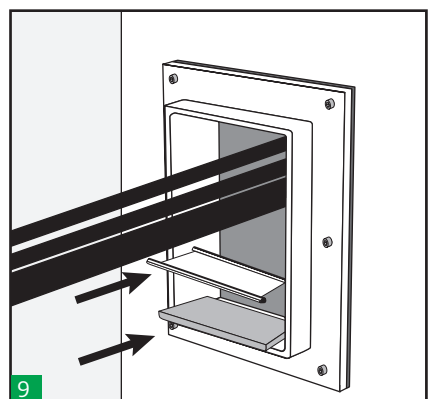

9 Before starting the sealing, place a 5mm strip with a stayplate at the bottom of the frame. These are included with compression system.

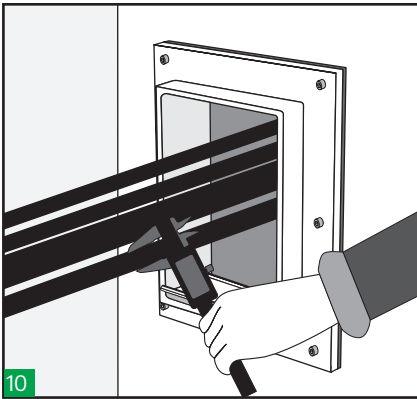

10 Take measures of the cables diameter with a calibre and select the appropriate Hawke tolerant blocks. Colour code will help you to select the correct ones.
Only use H-DM black blocks.

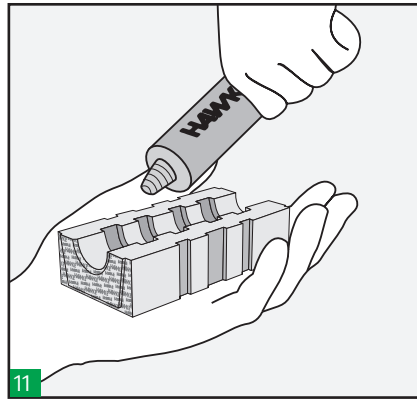

11 Lubricate all the insert and blank blocks, using Hawke lubricant.

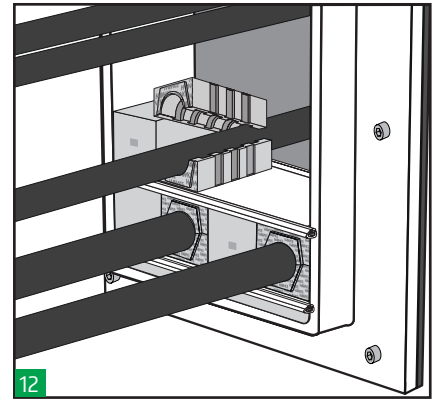

12 Keep sealing the transit from the bottom to the top using insert and blank blocks, as required.

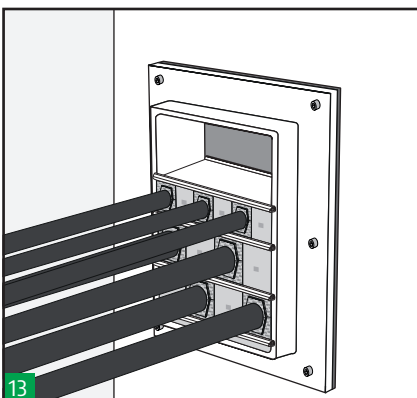

13 A stayplate is always inserted between each layer of blocks.

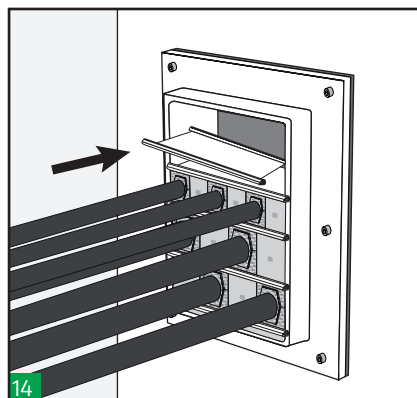

14 Insert the last stayplate before the last row of blocks (or earlier if required). Verify that the complete sealing area of this frame size (see table) will be filled with blocks. Note: 5mm strip supplied with the compression system should be not considered as part of the sealing area.

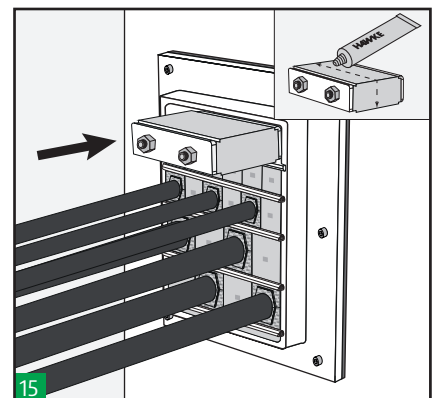

15 Pack the last row between the two last stayplates. Lubricate and insert H-DM endpacker at the top of the frame.

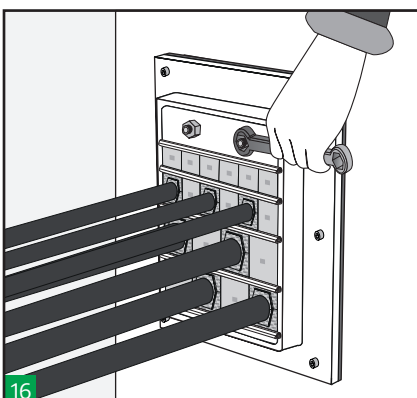

16 Tighten the nuts on the endpacker in alternate order to compress and complete the seal.

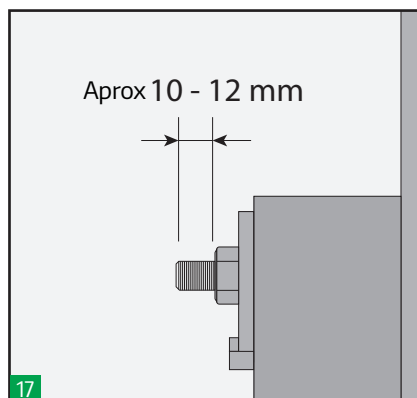

17 Approximately 10-12 mm of thread should protrude on each bolt.

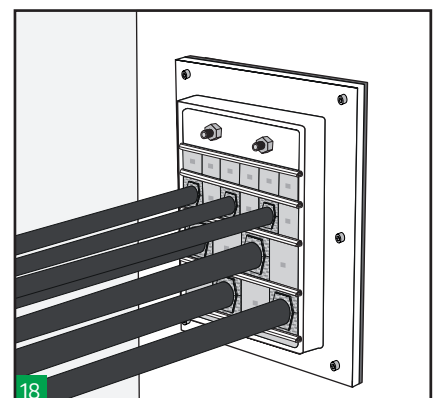

18 Make a visual inspection of the transit. Hawke's colour coding enables the installation to be visually inspected after completion and ensures correct matching of the blocks halves.

HTS-EN-A1006-Rev04-12/21

◆ → Sealing Area

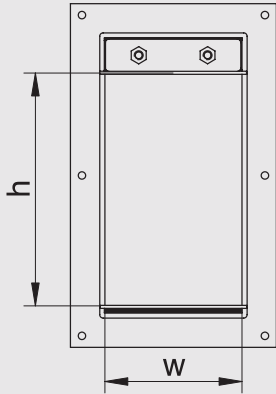

DESCRIPTION	SEALING AREA (mm)
H-DM 1	60x60
H-DM 4	120x120
H-DM 5	60x180
H-DM 6.3	120x200
H-DM 6+6	2x (120x180)

◆ → Hole dimension

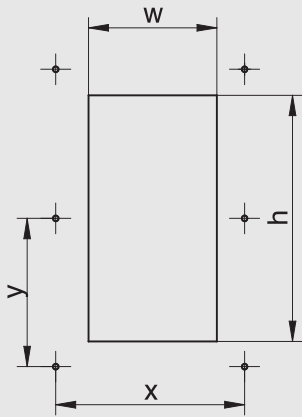

DESCRIPTION	HOLE DIMENSIONS		BOLTS POSITION		
	w (mm)	h (mm)	Φ (mm)	x (mm)	y (mm)
H-DM 1	77	117	6	100	140
H-DM 4	137	177	6	160	100
H-DM 5	77	235	6	100	126
H-DM 6.3	137	257	6	160	140
H-DM 6+6	137	458	6	160	120

*All dimensions are nominal values

◆ → Notes

Leave the system at least 24 hours before applying pressure.
For disassembly see disassembly installation instructions.

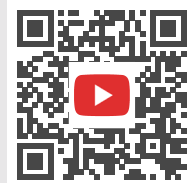

→ **RECTANGULAR EMC SYSTEM** installation guide:

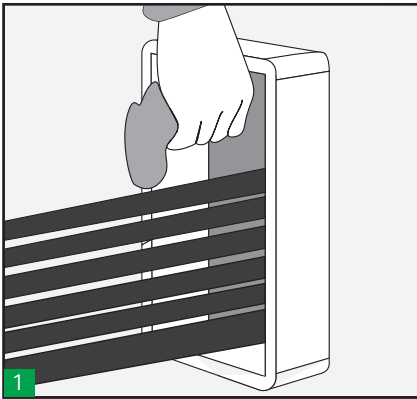

1 Make sure the frame is clean, then pull cables or pipes through, placing the largest at the bottom. (Note: Use open ended frame to fit around existing cables/pipes)

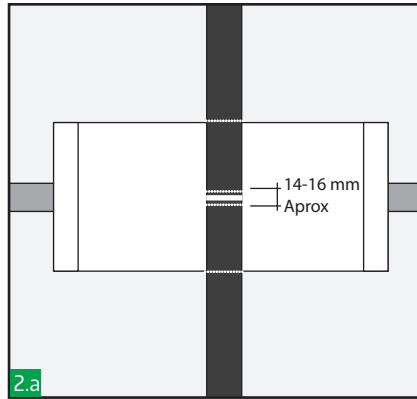

2.a Mark each cable in the centre of the frame and 7-8mm either side of this point. Also, recommendable to mark the cable in both ends of the frame. EMC marking tool could help you to reduce time and ensure a correct marking.

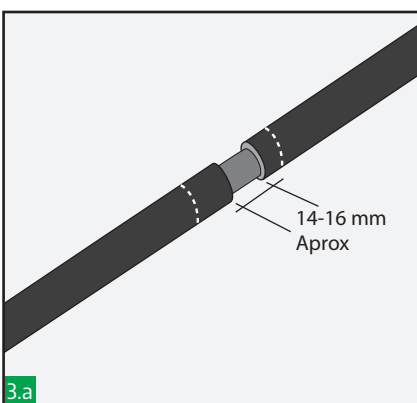
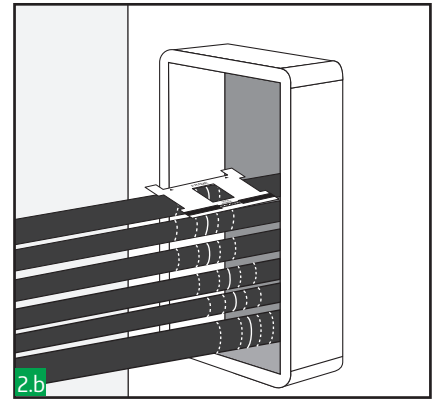

3.a Cut and remove cable sheath between two central marks, to expose the cables conductive screen.

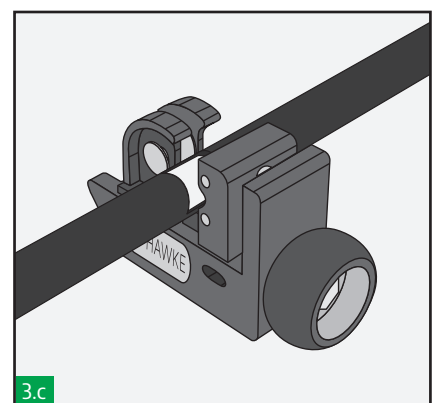
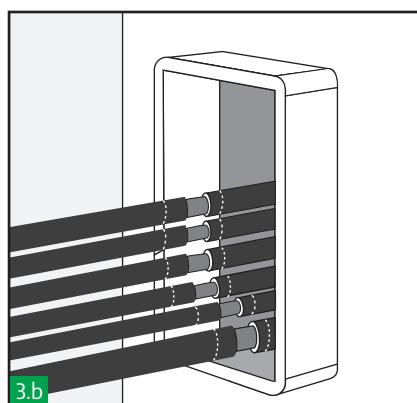

3.c EMC cable sheath remove tool could help you to reduce time and ensure a correct cutting.

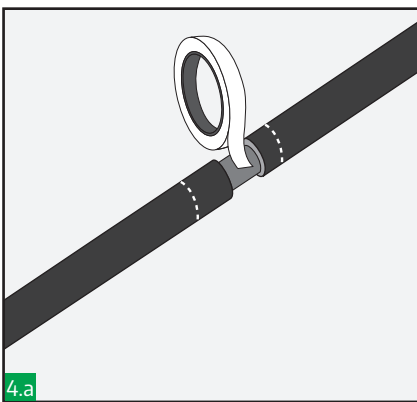

4.a Using copper tape provided tightly wrap around the exposed screen until the cable outer diameter is regained. Repeat these steps for all cables.

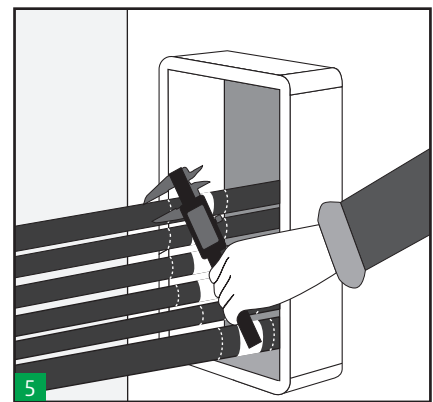
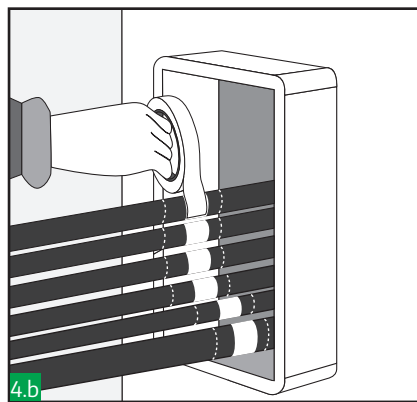

5 Take measures of cables diameters and select the appropriate Hawke tolerant blocks.

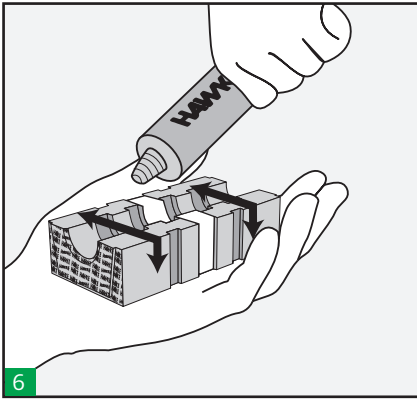

6

Very slightly lubricate all the insert and blank blocks using Hawke lubricant taking care not to contaminate the copper on blocks and cables.

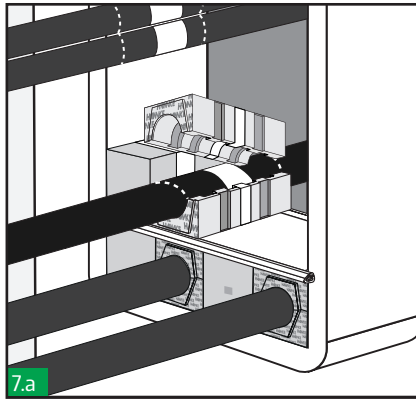

7a

Begin packing the frame from the bottom to the top. A stayplate is always inserted between each layer of blocks. Blocks should not protrude out of the stayplates retaining lips. Ensure when fitting cables into blocks that copper tape on blocks and cable align. Marks in the cable will help to guarantee it.

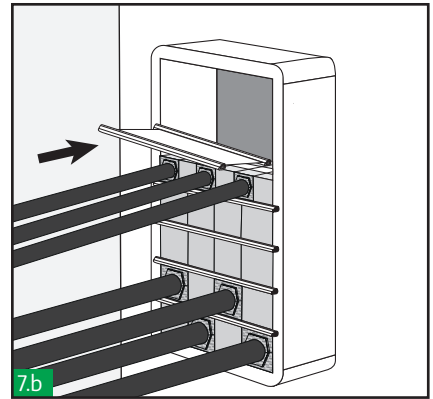

7b

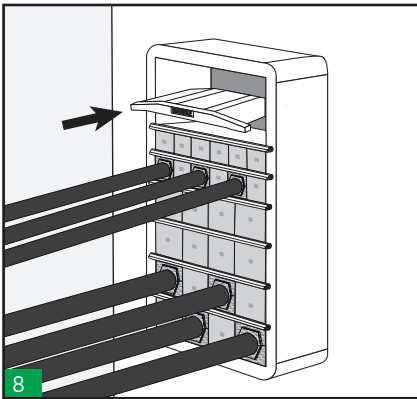

8

Insert the last stayplate and the compression plate before the last row of blocks (or earlier if required). Check frame packing space. Verify that the complete sealing area of this frame size (see table) will be filled with blocks.

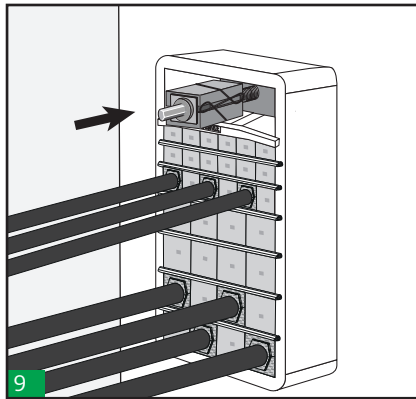

9

Pack the last row between the last stayplate and the compression plate. Insert the compression tool on the top, in the centre of the compression plate.

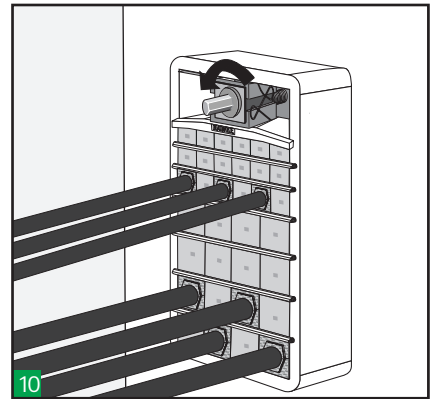

10

Tighten the compression tool until there is sufficient room to fit the outer blocks of the endpacker.

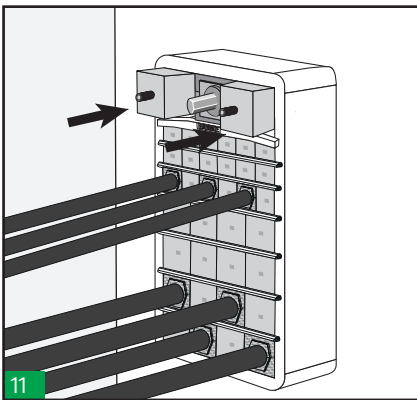

11

Insert the outer blocks of the endpacker. Then, untighten the compression tool and remove it.

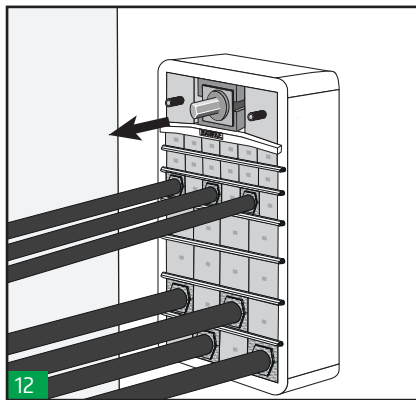

12

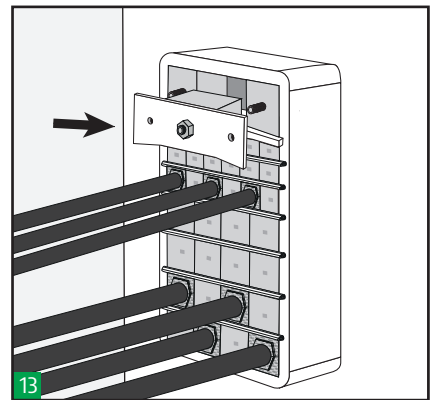

13

Insert the centre piece of the endpacker along with the front plate.

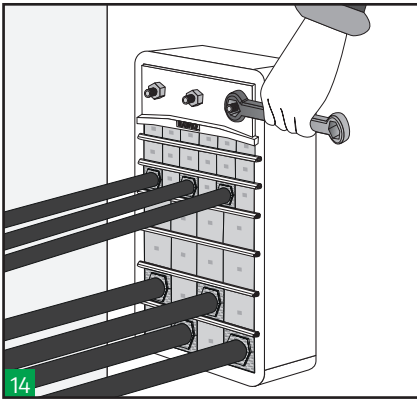

14 Tighten the nuts on the endpacking alternately following the above sequence to compress and complete the seal. Use a ratchet spanner for an easier installation.

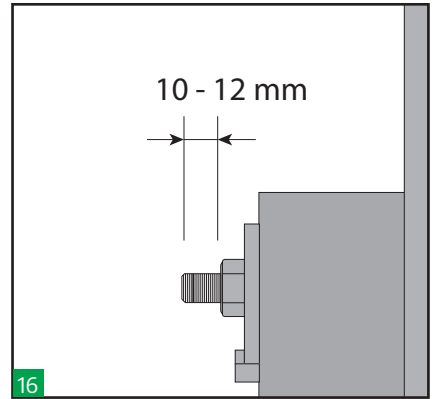
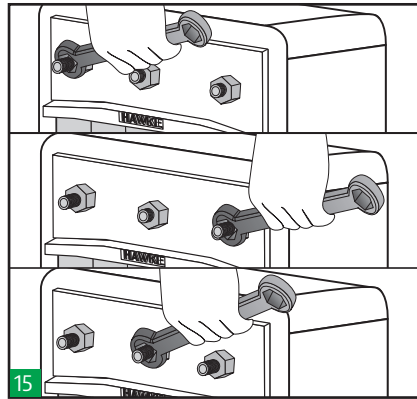

16 Approximately 10-12 mm of thread should protrude on each bolt to ensure the sealing.

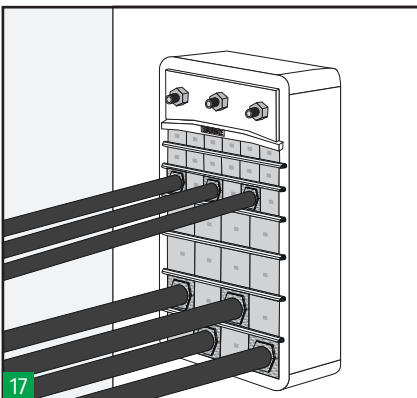

17 Make a visual inspection of the transit. Check that marks in all the cables are visible to guarantee blocks and cable copper tapes are aligned.

◆ Notes

Leave the system at least 24 hours before applying pressure. For disassembly see disassembly installation instructions.

◆ Sealing Area

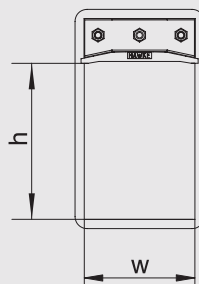

APERTURE SIZE	SEALING AREA (w x h)
1	60 x 60
2	120 x 60
3	60 x 120
4	120 x 120
5	60 x 180
6	120 x 180
7	60 x 240
8	120 x 240



→ **HMCX EMC SYSTEM** installation guide:

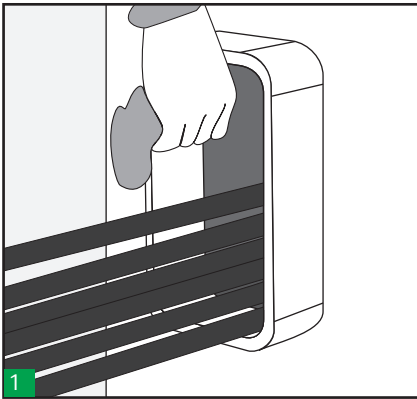

1 Make sure the frame is clean, then pull cables or pipes through, placing the largest at the bottom. (Note: Use open ended frame to fit around existing cables/pipes)

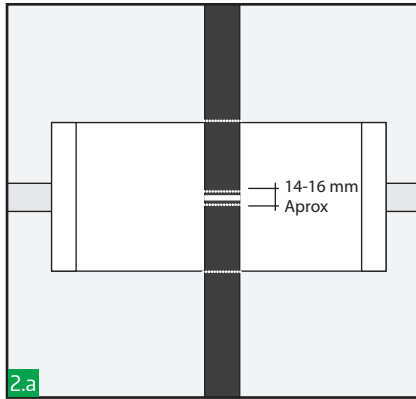

2.a Mark each cable in the centre of the frame and 7-8mm either side of this point. Also, recommendable to mark the cable in both ends of the frame. EMC marking tool could help you to reduce time and ensure a correct marking.

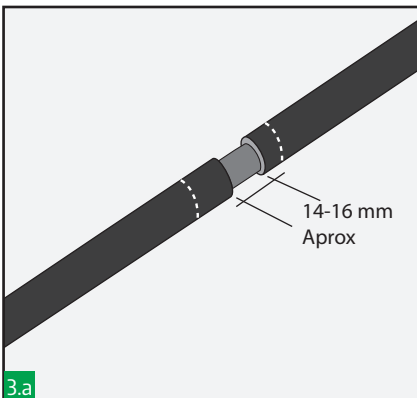
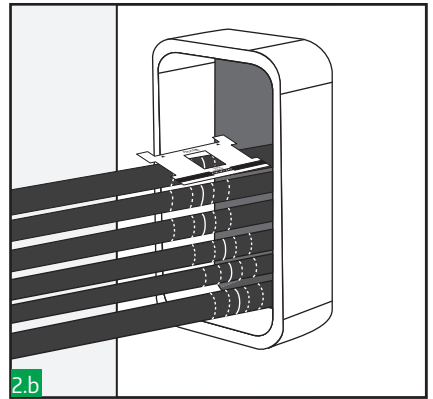

3.a Cut and remove cable sheath between two central marks, to expose the cables conductive screen.

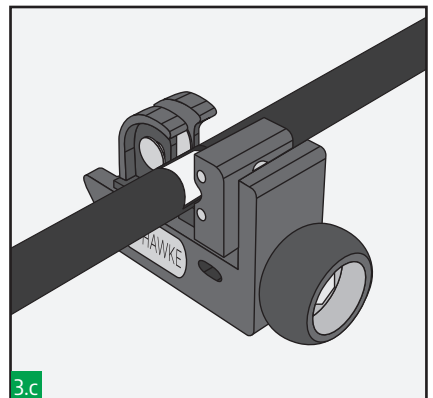
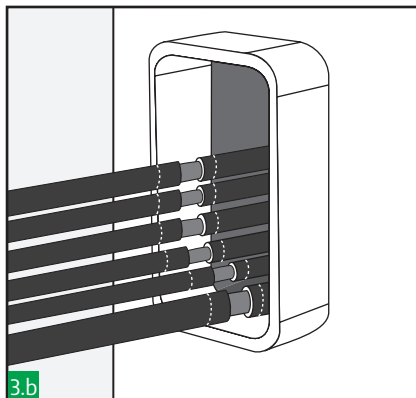

3.c EMC cable sheath remove tool could help you to reduce time and ensure a correct cutting.

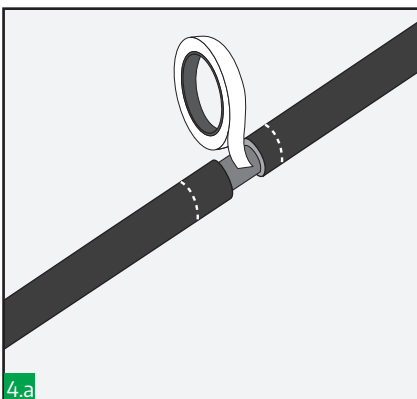

4.a Using copper tape provided tightly wrap around the exposed screen until the cable outer diameter is regained. Repeat these steps for all cables.

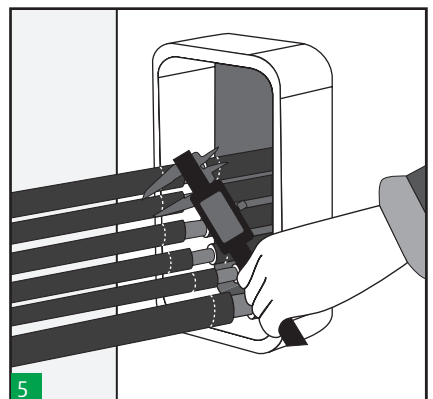
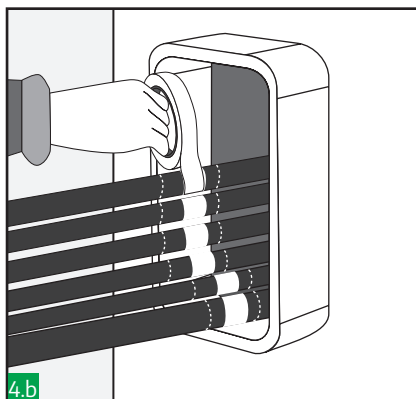

5 Take measures of cables diameters and select the appropriate Hawke tolerant blocks.

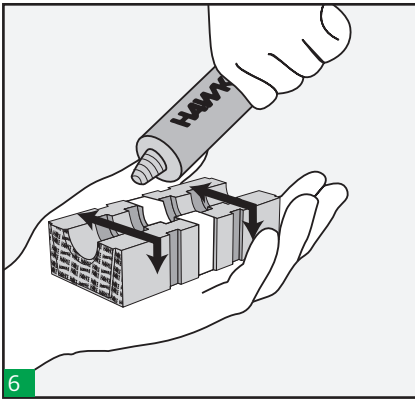

6 Very slightly lubricate all the insert and blank blocks using Hawke lubricant taking care not to contaminate the copper on blocks and cables.

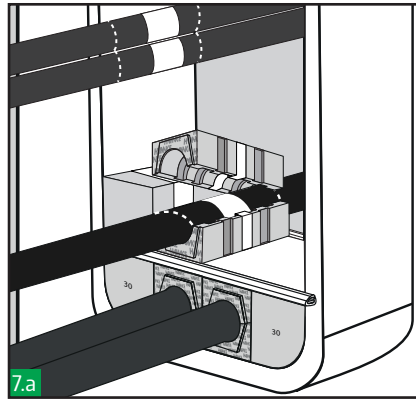

7.a Begin packing the frame from the bottom to the top. A stayplate is always inserted between each layer of blocks. Blocks should not protrude out of the stayplates retaining lips. Ensure when fitting cables into blocks that copper tape on blocks and cable align. Marks in the cable will help to guarantee it.

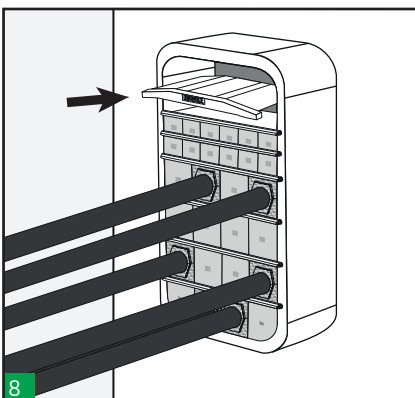
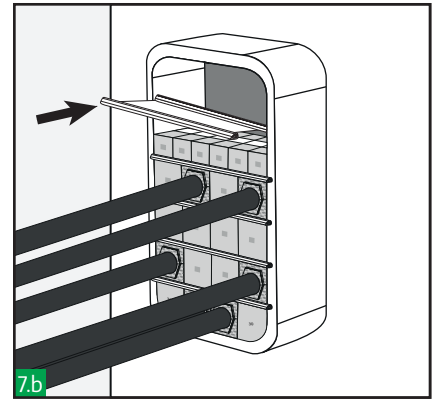

8 Insert the last stayplate and the compression plate before the last row of blocks (or earlier if required). Check frame packing space. Verify that the complete sealing area of this frame size (see table) will be filled with blocks.

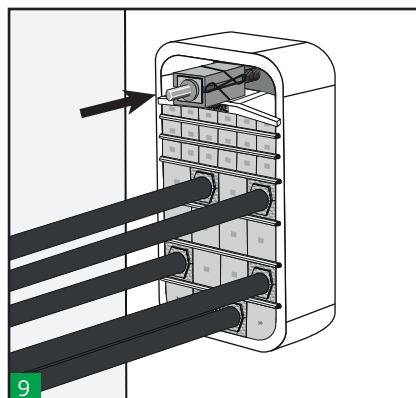

9 Pack the last row between the last stayplate and the compression plate. Insert the compression tool, in the centre of the compression plate.

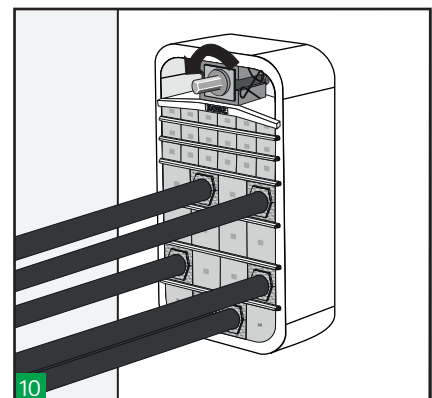

10 Tighten the compression tool until there is sufficient room to fit the outer blocks of the endpacker.

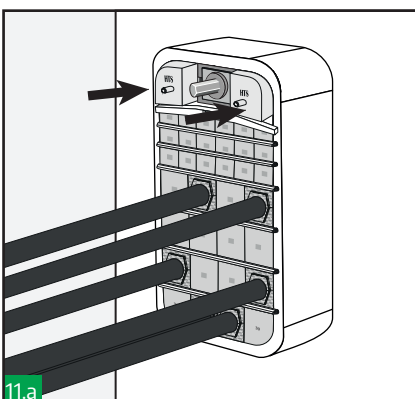

11.a Insert the outer blocks of the endpacker. Then, untighten the compression tool and remove it.

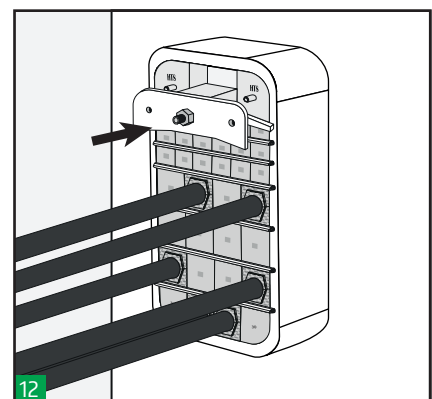
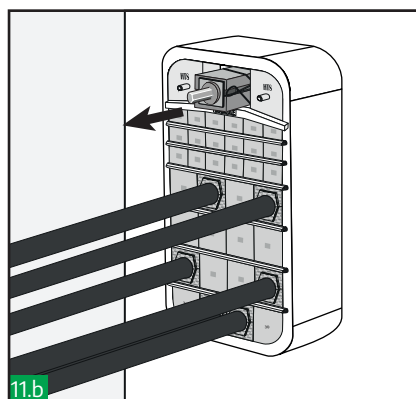

12 Insert the centre piece of the endpacker along with the front plate.

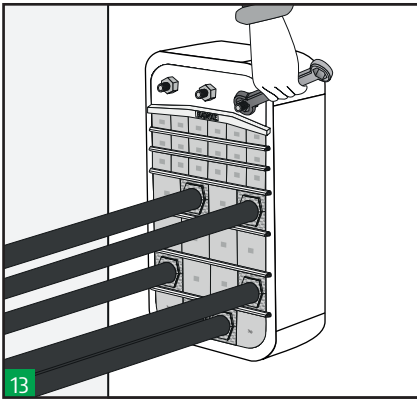

13

Tighten the nuts on the endpacking alternately following the above sequence to compress and complete the seal. Use a ratchet spanner for an easier installation.

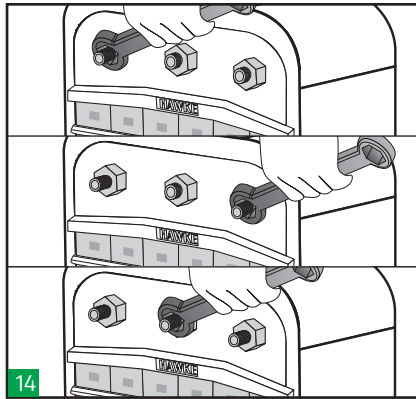

14

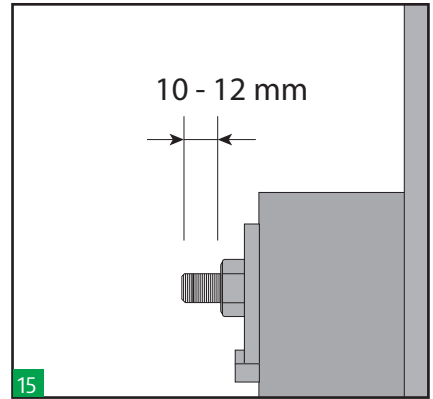

15

Approximately 10-12 mm of thread should protrude on each bolt to ensure the sealing.

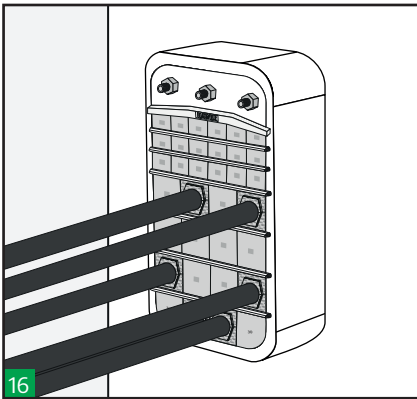

16

Make a visual inspection of the transit. Check that marks in all the cables are visible to guarantee blocks and cable copper tapes are aligned.



Notes

Leave the system at least 24 hours before applying pressure. For disassembly see disassembly installation instructions.



Sealing Area

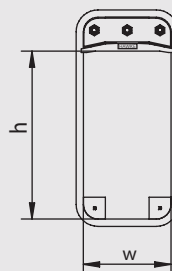

SIZE	SEALING AREA (w x h)
2	120x60
4	120x120
6	120x180
8	120x240

→ **HRTO / HRT EMC ROUND SYSTEM** installation guide:

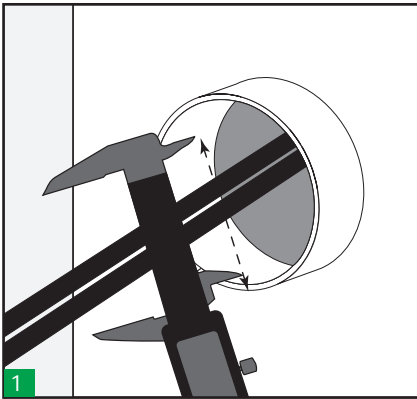

Measure the inside of pipe aperture to ensure that it is within the tolerance of the round transit frame to be used.

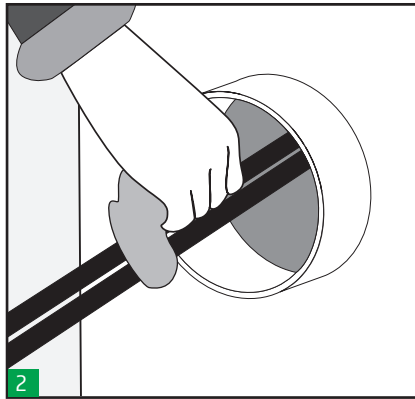

Make sure the frame is clean and there are not rust.

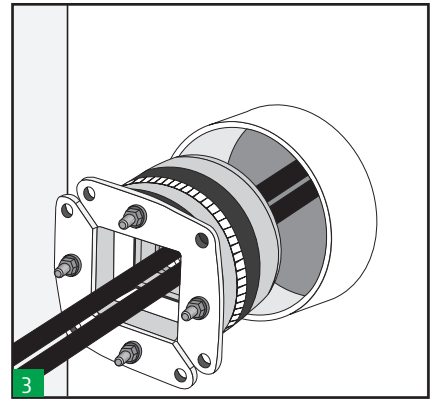

Insert the round transit frame completely in the sleeve around the cables and open the two front plates. (HRTO30,HRTO40&HRTO50 front plates are fixed). No lubricant should be applied to the aperture or outside of the frame.

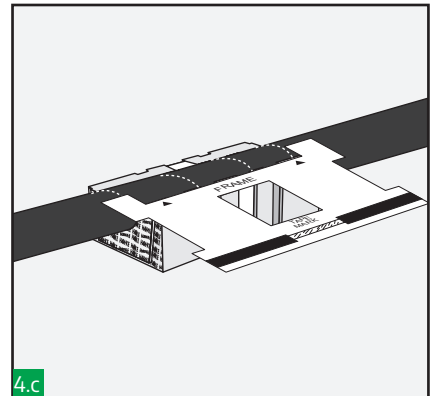
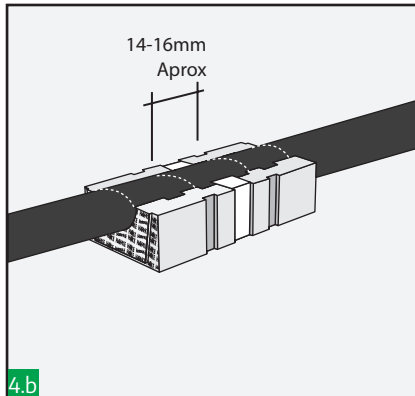
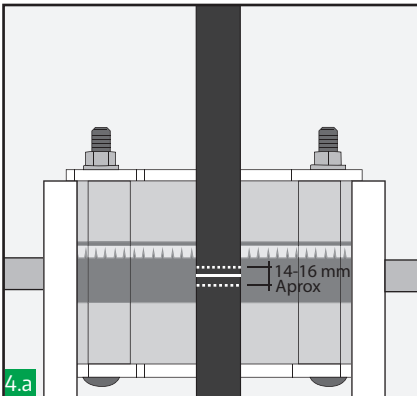

Mark each cable in the centre of the frame and 7-8mm either side of this point. Also, recommendable to mark the cable in both ends of the frame.

EMC marking tool could help you to reduce time and ensure a correct marking.

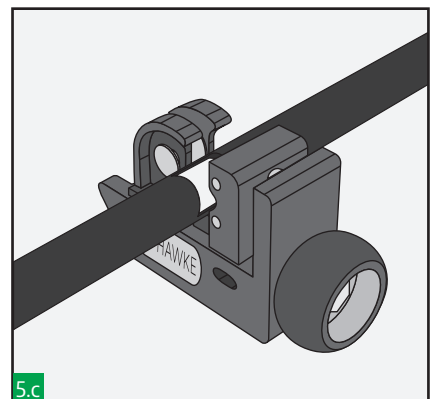
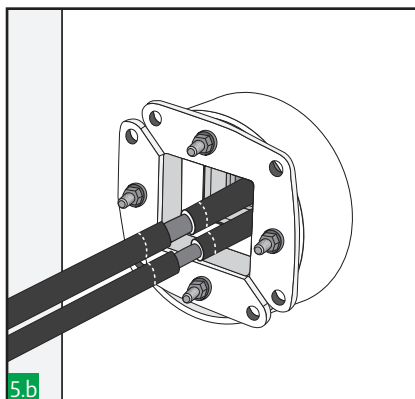
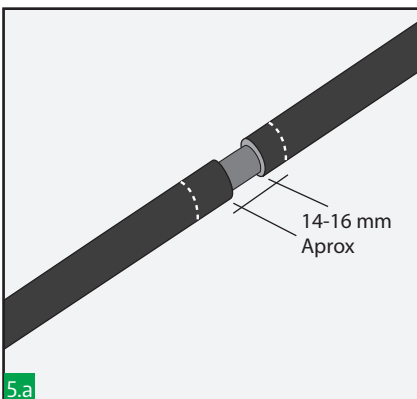

Cut and remove cable sheath between two central marks, to expose the cables conductive screen.

EMC cable sheath remove tool could help you to reduce time and ensure a correct cutting.

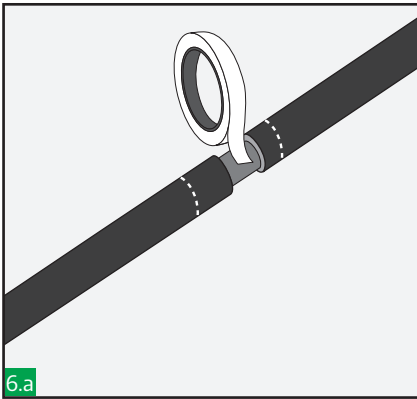

6.a

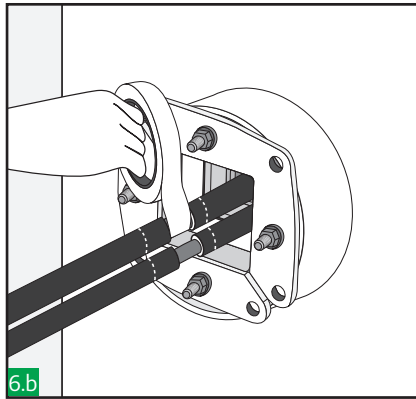

6.b

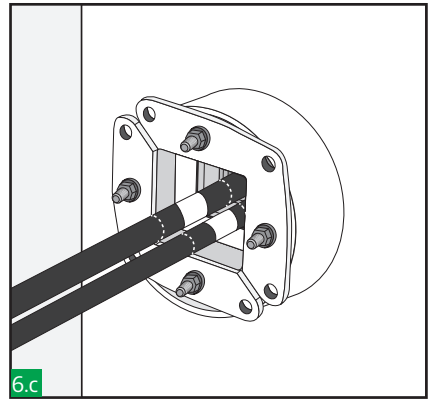

6.c

Using copper tape provided tightly wrap around the exposed screen until the cable outer diameter is regained. Repeat these steps for all cables.

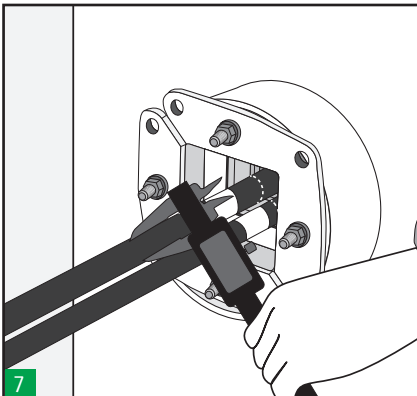

7

Take measures of the cables diameters and select the appropriate Hawke Tolerant Blocks.

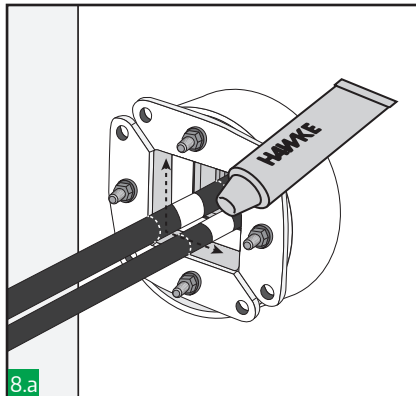

8.a

Lubricate the inside of the HRTO and all the insert and blank blocks using Hawke lubricant. Be careful don't contaminate the copper tape.

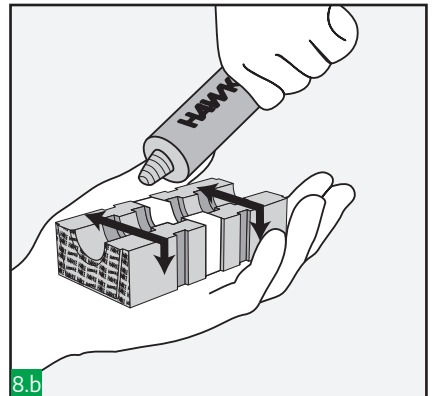

8.b

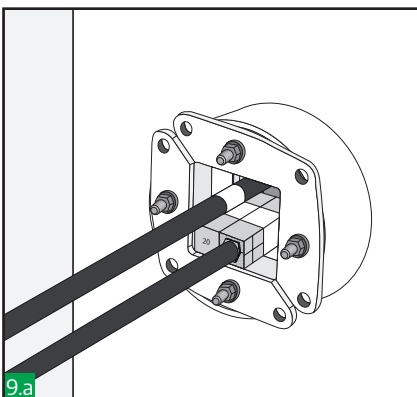

9.a

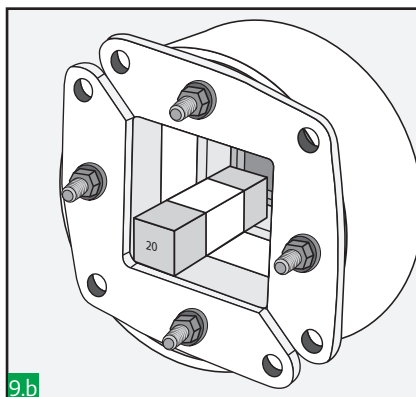

9.b

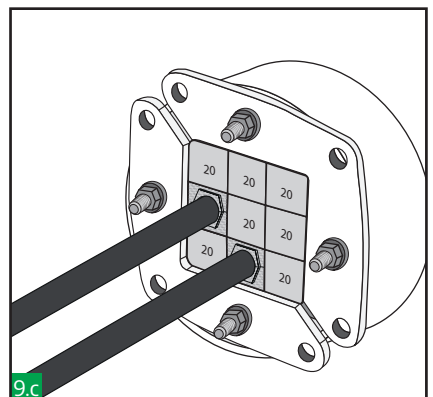

9.c

Begin packing the transit frame starting at the bottom and finishing at the top. Ensure that the blocks are pushed firmly against the rear retaining lip. Verify that the complete sealing area of this frame size (see table) is filled with blocks.

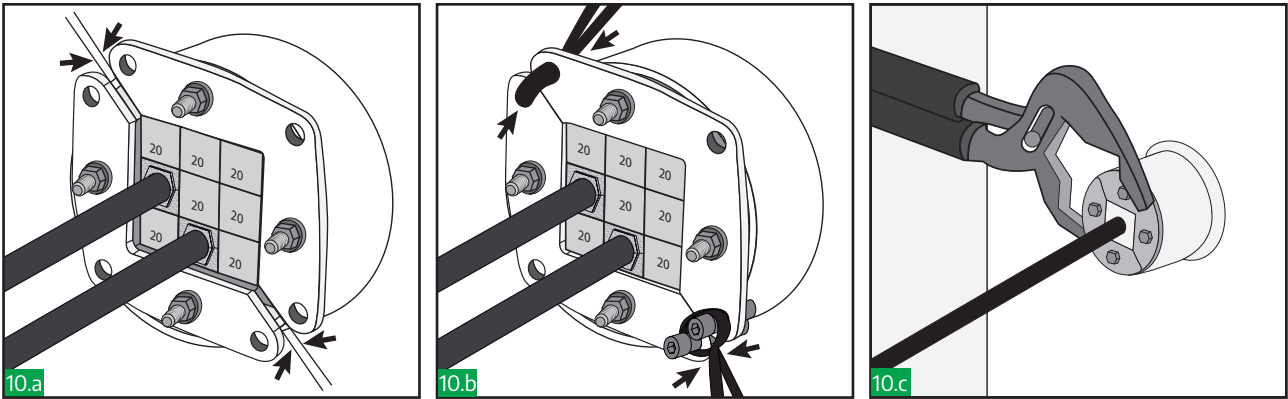

Slide the two front plates together and keep it fixed. Ensure all the blocks are located inside the front retaining lip.
For an easier installation, cable ties, bolts or adjustable pliers can be used to close this plates.

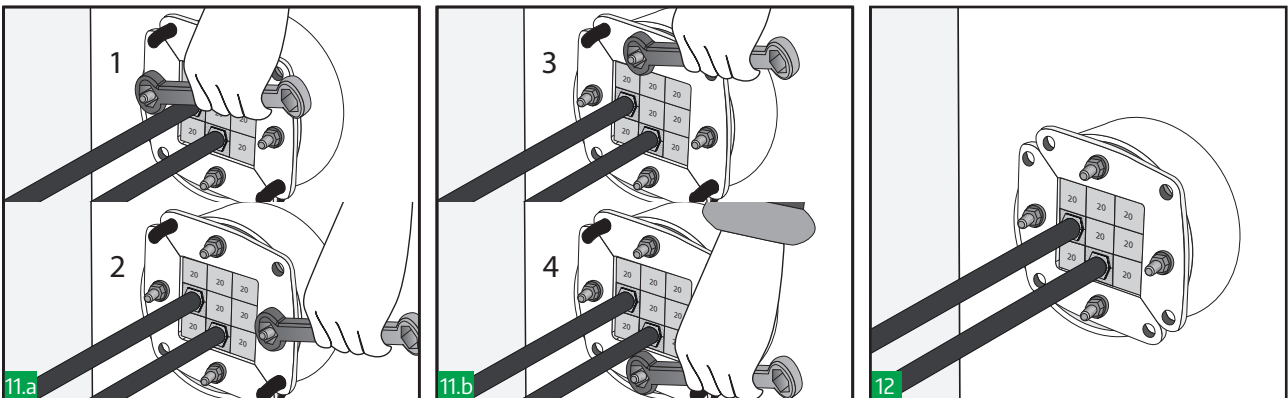

Tighten the nuts approximately 2mm each time following alternate tightening sequence, applying equal pressure to both plates.
A minimum of 10 mm of thread should protrude on each bolt.
Use a ratchet spanner for an easier installation.

Make a visual inspection of the transit.
Check that marks in all cables are visible to be guarantee blocks and cable copper tapes are aligned.

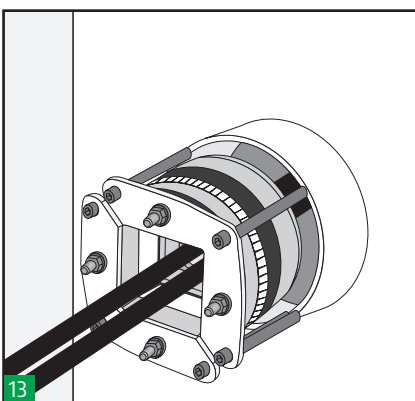

Extraction is achieved by releasing the compression, i.e. by reversing steps 10 and 11 and screwing M8 bolts (not supplied) into the threaded holes at each corner of the front plates. These releases the assembly from the aperture and allows the system to be disassembled.

- ◆ Notes
 - Leave the system at least 24 hours before applying pressure.
 - For disassembly see disassembly installation instructions.

◆ Sealing Area

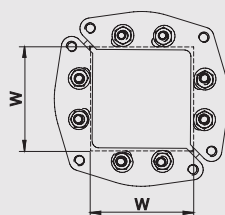

TYPE	SEALING AREA (mm)
HRTO-30	15x15
HRTO-40	20x20
HRTO-50	30x30
HRTO-70	40x40
HRTO-100	60x60
HRTO-125	80x80
HRTO-150	90x90
HRTO-200	120x120



→ **COMPRESSION TOOL** Use guide:

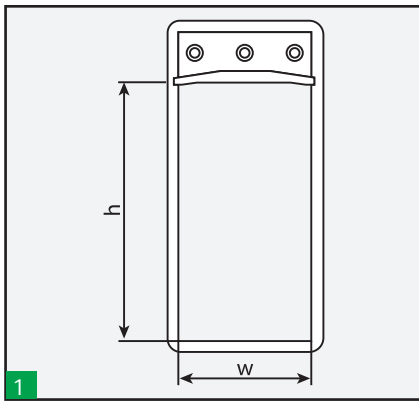

1 Before using the compression tool, it is important to check that the complete sealing area of this frame size (see table) is filled with blocks. Thus over tightening of the tool can be avoided.

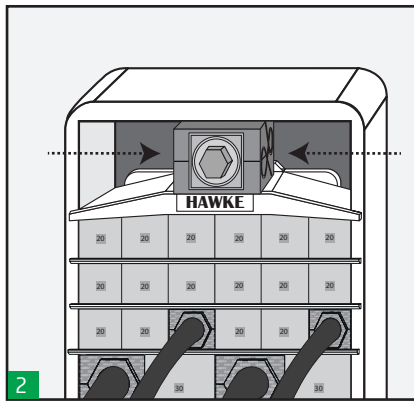

2 Compression tool must be introduced centred in the frame both in width and depth since otherwise the compression of the system would not be balanced so that to be able to introduce the lateral pieces of the endpacker it would be necessary to over tighten the tool and it could be damaged.

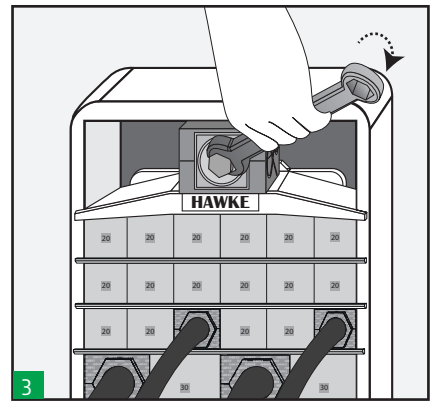

3 Once centred, we begin to tighten the compression tool which will be pressing on the compression plate.

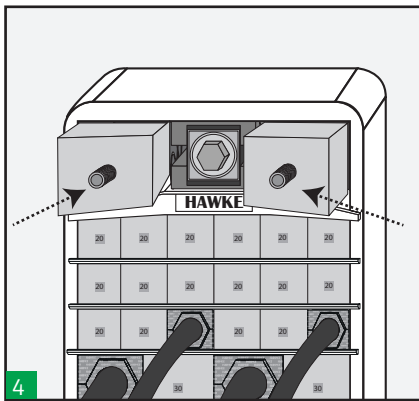

4 Before reaching the limit of tightening we must check if we have enough space to introduce the endpacker lateral pieces to avoid over tightening the tool that could block it.

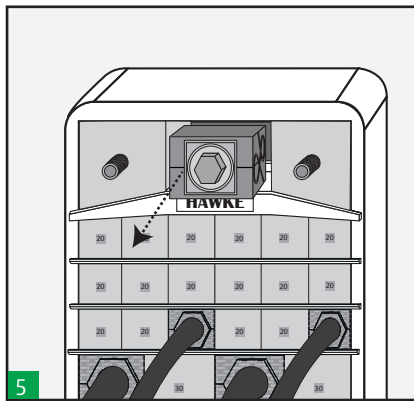

5 Insert the outer blocks of the endpacker. Then, untighten the compression tool and remove it.

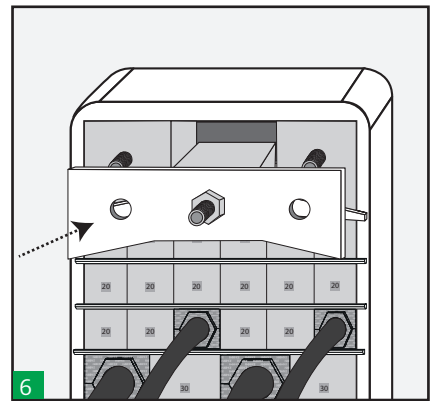

6 Insert the centre piece of the endpacker along with the front plate.

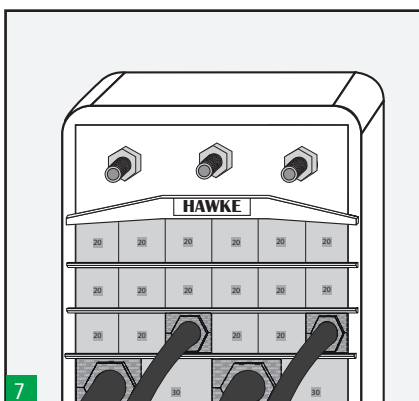

7 Tighten the nuts on the endpacker alternately following the above sequence to compress and complete the seal. Use a ratchet spanner for an easier installation. Approximately 10-12 mm of thread should protrude on each bolt to ensure the sealing.

◆ Recommendations of good use.

- Avoid damaging the compression tool by hitting it when you introduce it into the frame.
- Avoid dropping the tool.
- Avoid block the tool with an unnecessary over tighten.
- Grease the tool for a longer lifetime.

◆ Sealing Area.

APERTURE SIZE	SEALING AREA (w x h)
1	60 x 60
2	120 x 60
3	60 x 120
4	120 x 120
5	60 x 180
6	120 x 180
7	60 x 240
8	120 x 240

→ **PULLER** Use guide:

For future modification of the transit the system must be capable of being broken down. This is simple to achieve with a basic reversal of the assembly method the described in the installation instructions. The only exception is the use of the puller tool to remove the Endpacker centre block.

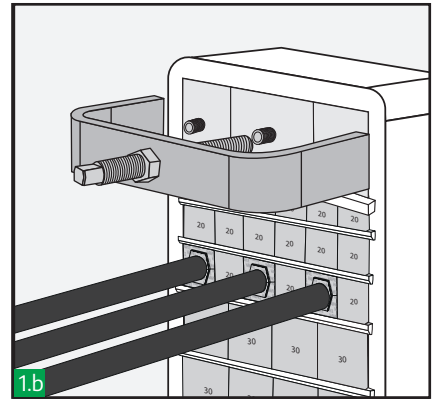
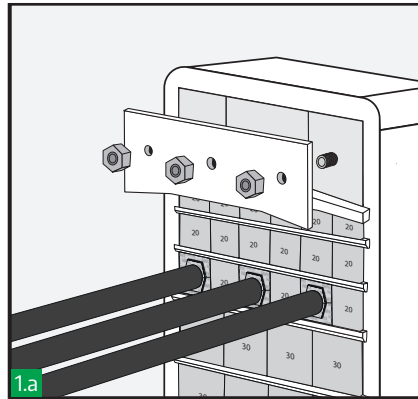

Remove endpacker nuts and front plate.

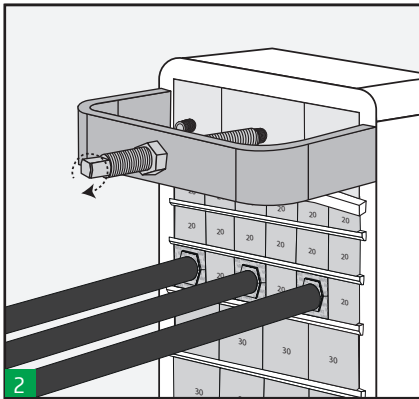

Remove endpacker nuts and front plate.

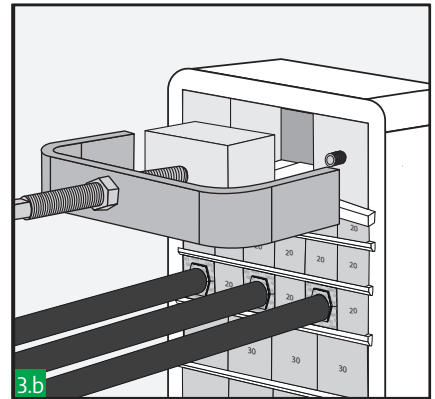
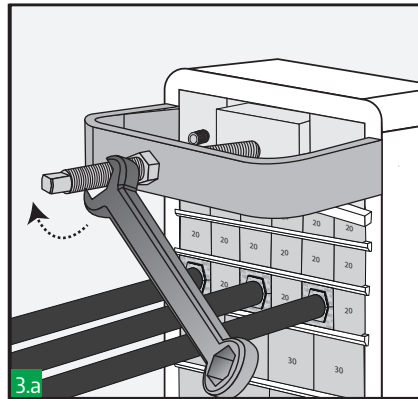

The nut of the puller is then turned clockwise and the centre block is then jacked out of the assembly.

 → **CLAMP TOOL** Use guide:

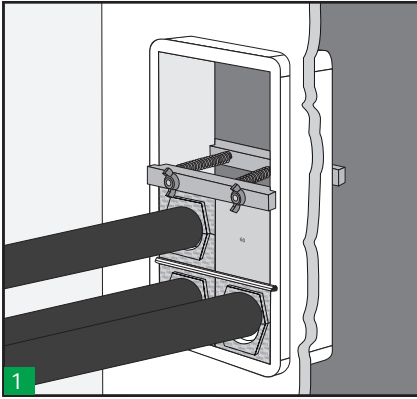

Clamp Tool can be used to fix blocks in their place when the transit installation is not completely finished.

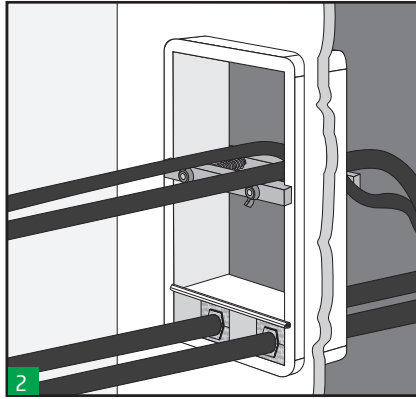

Clamp tool can be used to fix cables on the top part of the penetration allowing an easier installation of blocks.

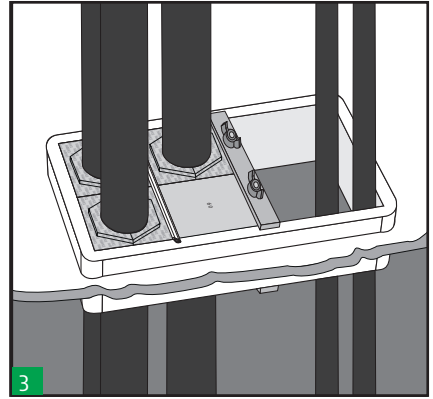

Likewise, with this tool you must achieve greater comfort in a horizontal transit. Keeping blocks in position avoiding falling blocks.

→ RECTANGULAR CIVIL FRAMES INSTALLATION GUIDES

There are methods which can be used to install Hawke Civil Frames, each method giving an inspectable professional finish to any cable/pipe penetration.

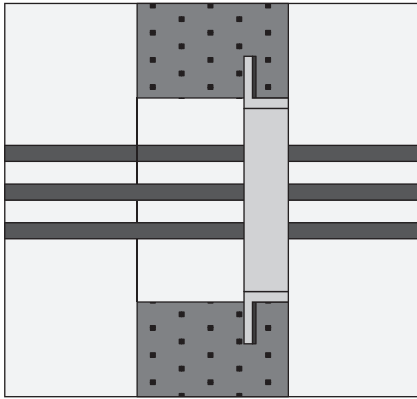

Figure 1

The frame can be casted directly into a wall or floor.

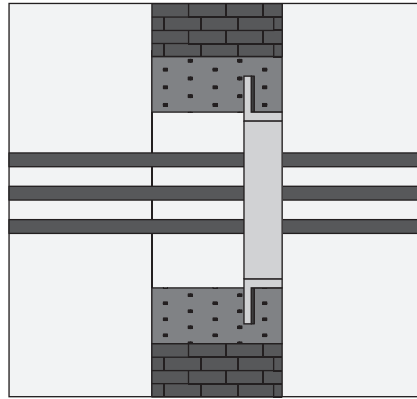

Figure 2

The frame may be cast into a concrete jacket. This method being normally used for brick and blockwork walls which in turn is fixed into the wall or floor.

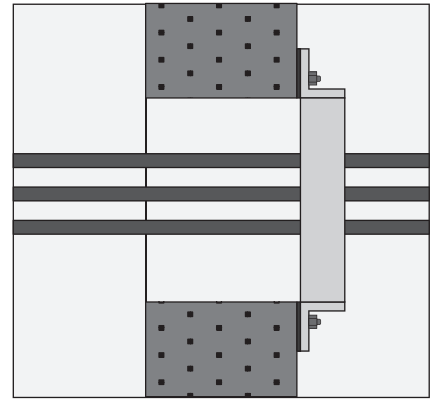

Figure 3

The frame can be bolted to wall and floors.

→ CASTED

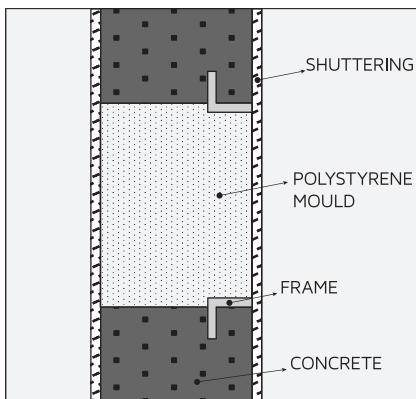

Figure 1

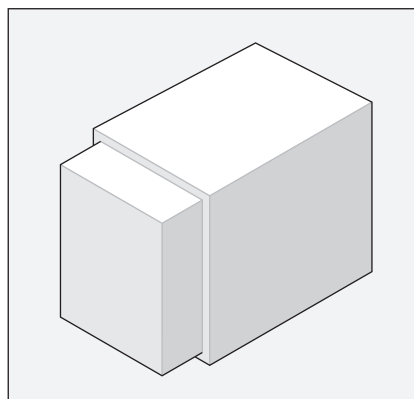

Figure 2

For hawke frames which are cast into a wall or floor it is recommended that a Hawke Polystyrene Mould is used. Hawke moulds are available to suit sizes 2, 4, 6 and 8 with 300mm lengths and may be cut to suit the deep of the wall or floor as required. (See catalogue page...79)

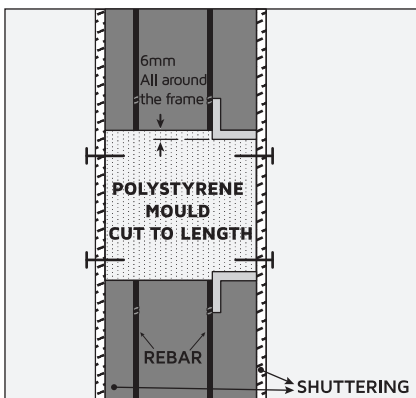

Figure 3

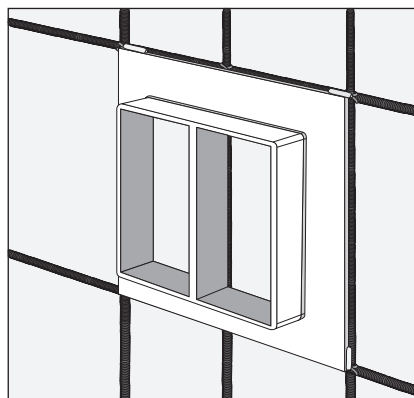

Figure 4

Frames and moulds require support to ensure that the correct position is maintained whilst the concrete is being poured. This may be achieved by nailing through the shuttering into the mould (if used) and fixing the frame to the rebar.

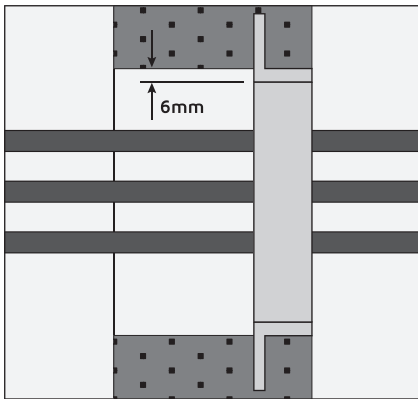

Figure 5

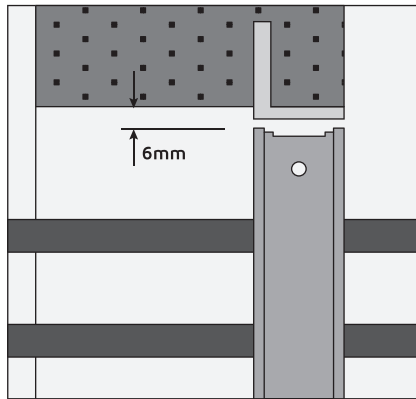

Figure 6

Stayplates and compression plates have retaining lugs. Clearance for these must be allowed when a frames are cast into a structure.

This allowance is 12mm and should be added to the total internal width of the frame to obtain the correct dimensions.

Hawke Moulds have this allowance built in.

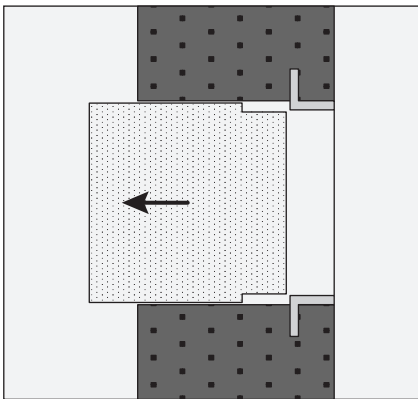

Figure 7

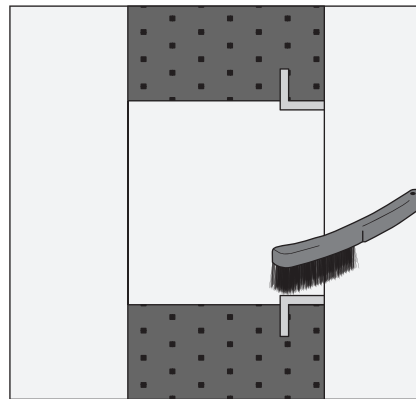

Figure 8

When all shuttering and other formwork has been removed, the polystyrene mould must be removed prior to electrical installation.

The transit aperture should be cleaned to remove any concrete or other debris that may have contaminated the apertures internal faces.

BOLTED

Frames can be bolted to floors and walls in either of the options showed below (HCOX frames, open version, can not be reverse fixed).

Stayplates and compression plates have retaining lugs, 6mm clearance is required to all sizes.

When frames are reverse fixed then 9mm clearance is required to all size frames.

For minimum aperture dimensions see table pag...145

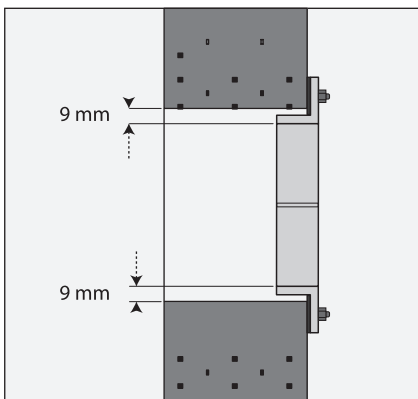

Figure 1.a

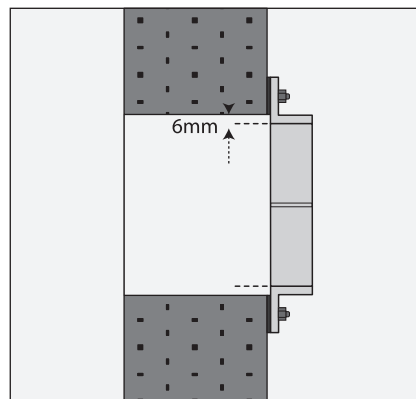

Figure 1.b

Size to fixing holes and type of fastener is to be established by the civil contractor dependent on size of frame weight and structure to which it is to be fixed.

When fixing frames to concrete/brick type structure care should be taken if using expanding type fixings as they could burst into the aperture.

BOLTED

For bolted installations Intumescent Mastic or Hawke Fireproof Silicone (See catalogue page 78) should be inserted between the frames flange and the structure.

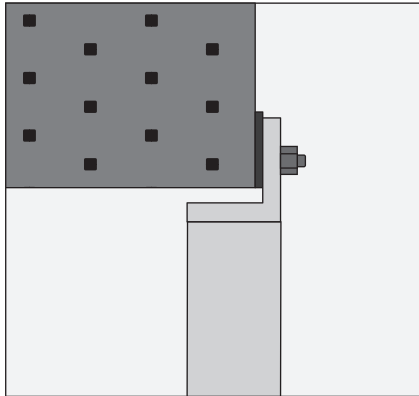

Figure 2.a

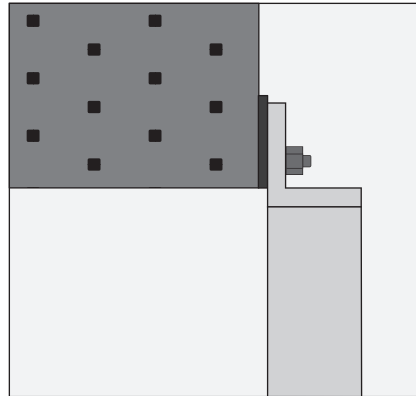

Figure 2.b

Each 300ml tube of Mastic/Silicone should be sufficient to mount and seal 3 individual frames or a multiple frame of up to 4 apertures.

Prior to application of sealant ensure that faces to be sealed are dry and free from grease and any loose material, ensure that transit frame mates up with any fixings/holes already present checking especially the apertures over which the frame is to be mounted. (See minimum aperture dimensions table).

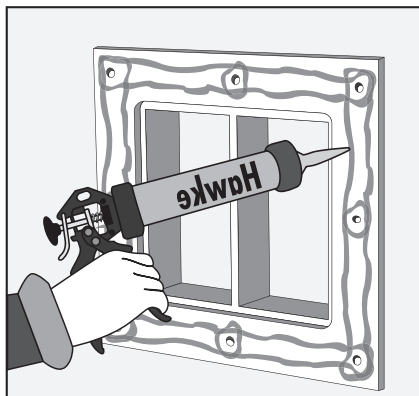

Figure 3.a

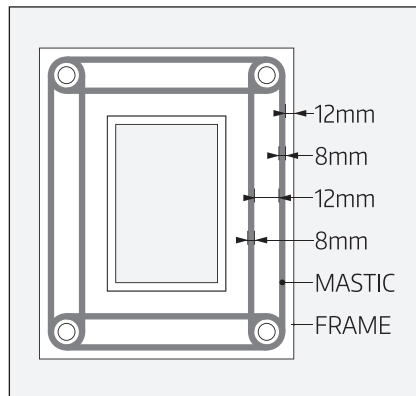

Figure 3.b

Cut nozzle on Mastic/Silicone tube to produce a bead diameter of approximately 8mm.

Apply two parallel rows of mastic and run a bead of mastic around each hole, as show below.

The Mastic/Silicone can be applied to front or rear of the frame dependant on the installation. See Fig.1 and Fig.2.

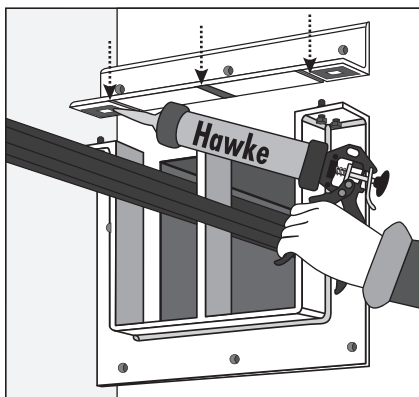

Figure 4.a

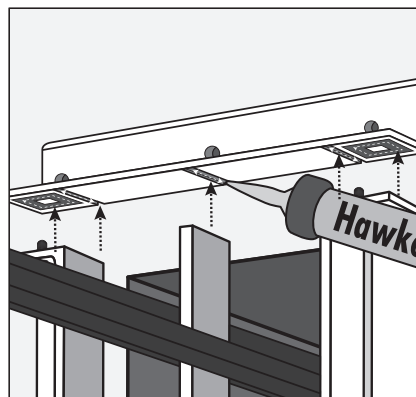

Figure 4.b

If HCOX open frame is used, Mastic/Silicone should be applied also in all bolting areas of the removable end as showed below.

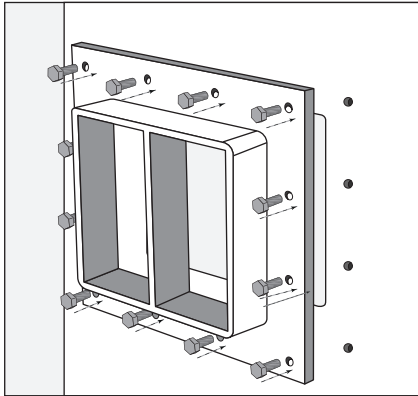

Figure 5

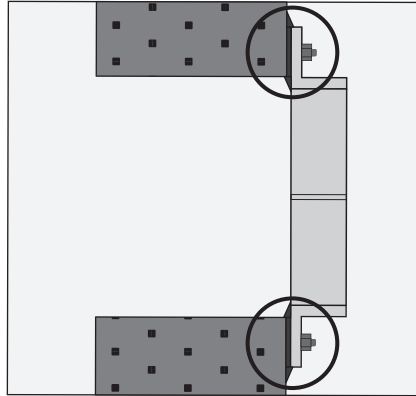

Figure 6

The frame can now be placed over its fixings and fasteners tightened to clamp the frame to the wall/floor.

When tightened up to the required amount, the Mastic/Silicone should be faced off to the frame leaving a fillet of Mastic/Silicone around external edges of the frame.

◆ → **BACKING PLATES**

Lightweight sheet steel backing plates are available to be used in conjunction with Hawke Civil Frames. Backing plates are produced in standard lengths for wall thickness of 60mm to 200mm for sizes 2,4,6 and 8, frames plus multiples there of, but specials can be made. Please state thickness of wall when ordering.

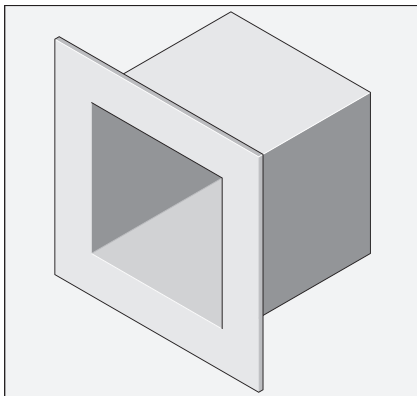

Figure 1.a

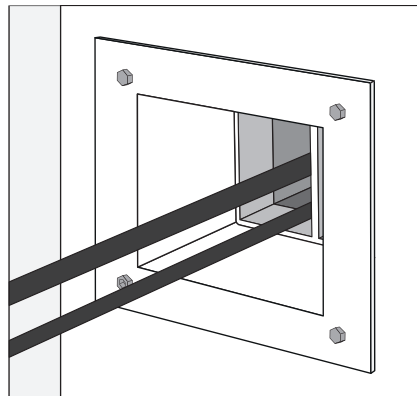

Figure 1.b

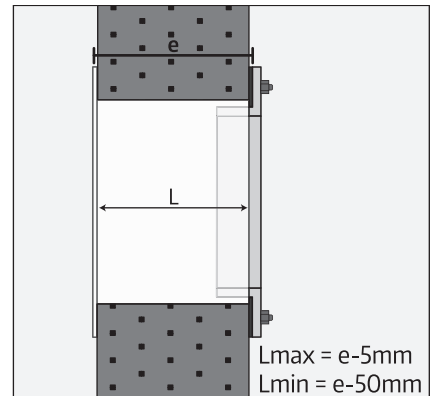

Figure 1.c

These maintain the openings through the wall and floors and add the finished appearance of the installation. It should be noted that the backing plates do not add to the fire resistance of a transit and should be not used to stop fire spread in cavity walls.

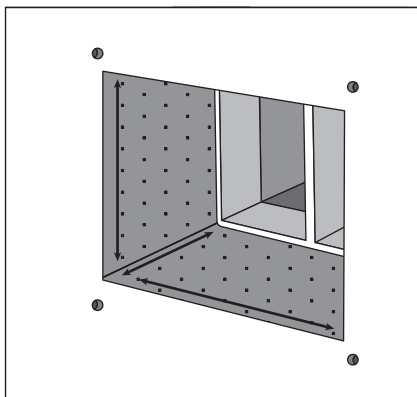

Figure 2.a

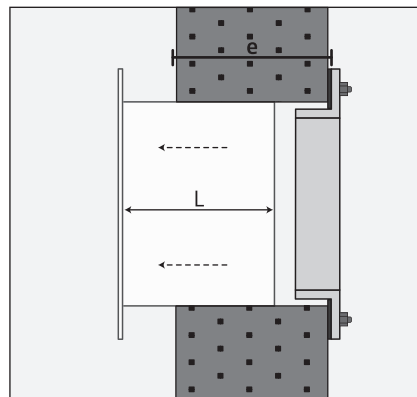

Figure 2.b

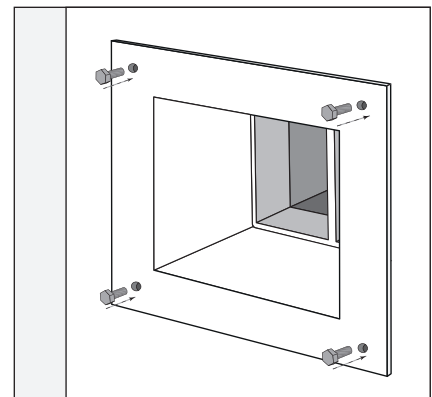

Figure 2.c

MINIMUM APERTURE DIMENSIONS WHEN FRAMES ARE CAST INTO OR BOLTED ONTO A WALL											
Frame Type	H (mm)	W (mm)									
		x 1	x 2	x 3	x 4	x 5	x 6	x 7	x 8	x 9	x 10
HCX 2 HCOX 2	119										
HCX 2+2 HCOX 2+2	230										
HCX 2+4 HCOX 2+4	288,5										
HCX 2+6 HCOX 2+6	347										
HCX 2+8 HCOX 2+8	405,5										
HCX 4 HCOX 4	177,5										
HCX 4+4 HCOX 4+4	347	138	268	398	528	658	788	918	1048	1178	1308
HCX 4+6 HCOX 4+6	405,5										
HCX 4+8 HCOX 4+8	464										
HCX 6 HCOX 6	236										
HCX 6+6 HCOX 6+6	464										
HCX 6+8 HCOX 6+8	522,5										
HCX 8 HCOX 8	294,5										
HCX 8+8 HCOX 8+8	581										

MINIMUM APERTURE DIMENSIONS WHEN FRAMES ARE CAST INTO OR BOLTED ONTO A WALL								
Frame Type	x 1		x N					For other HCLX frame styles and sizes please contact Hawke technical dept.
	H (mm)	W (mm)	W (mm)					
			x 2	x 3	x 4	x 5	x 6	
HCLX 180	236	198	388	578	768	958	1148	
HCLX 240	298	258	508	758	1008	1258	1508	
HCLX 360	458	378	748	1118	1488	1858	2228	

HTS-EN-AI013-Rev04-12/21

CIVIL SLEEVES INSTALLATION GUIDE

There are several methods which can be used to install Hawke Civil Sleeves, each method giving an inspectable professional finish to any cable/pipe penetration.

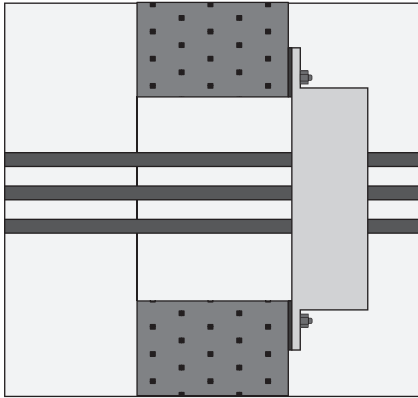

Figure 1

The sleeve can be bolted to wall and floors.

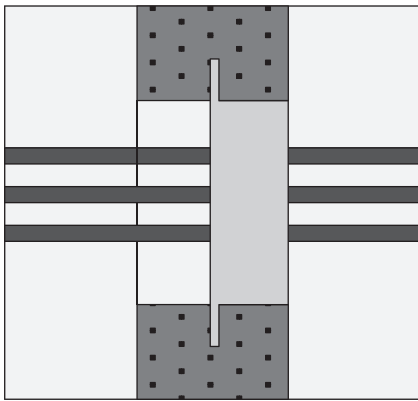

Figure 2.a

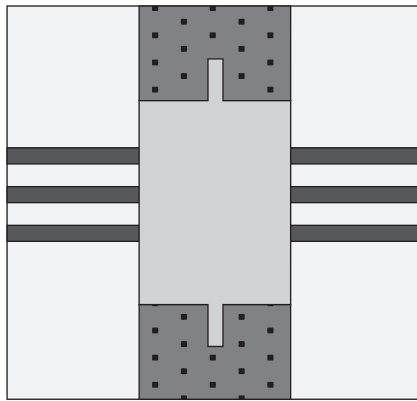

Figure 2.b

The sleeve can be casted directly into a wall or floor.

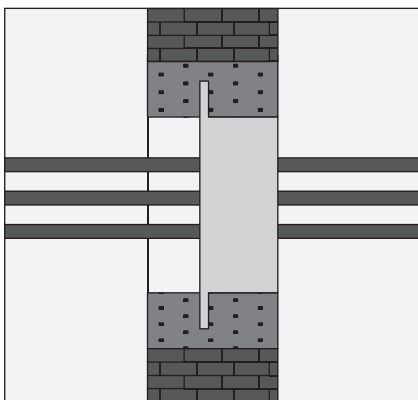

Figure 3.a

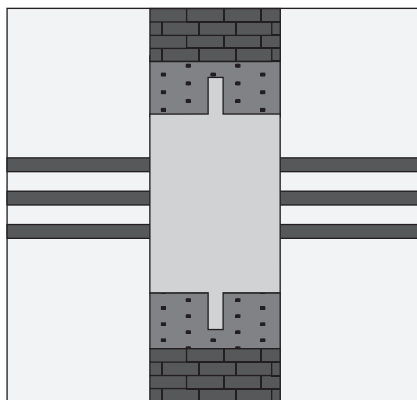

Figure 3.b

The sleeve may be cast into a concrete jacket. This method being normally used for brick and blockwork walls which in turn is fixed into the wall or floor.

◆ → **CASTED**

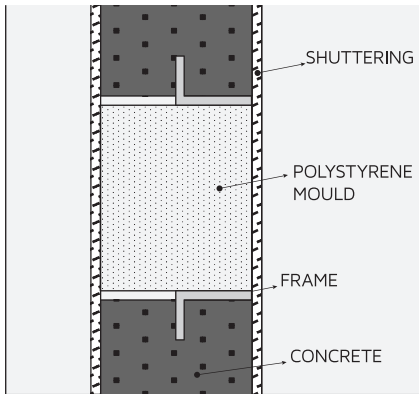

Figure 1.a

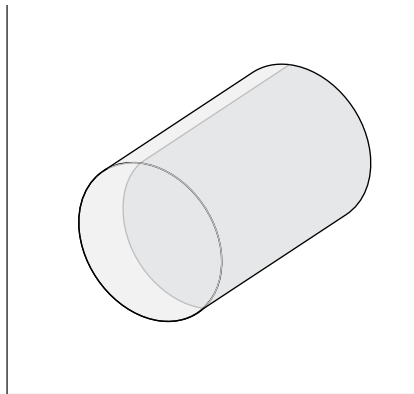

Figure 1.b

For Hawke sleeves which are cast into a wall or floor it is recommended that a Hawke Round Moulds is used. Hawke moulds are available to suit sizes 30, 40, 50, 70, 100, 125, 150, 175 and 200 with 300mm lengths and may be cut to suit the deep of the wall or floor as required.
(See catalogue page...79)

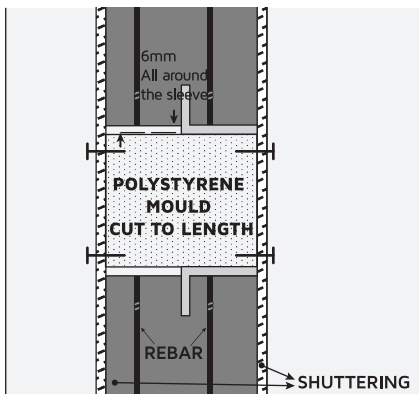

Figure 2.a

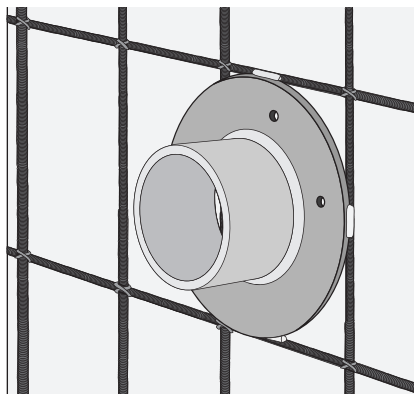

Figure 2.b

Sleeves and moulds require support to ensure that the correct position is maintained whilst the concrete is being poured. This may be achieved by nailing through the shuttering into the mould (if used) and fixing the frame to the rebar.

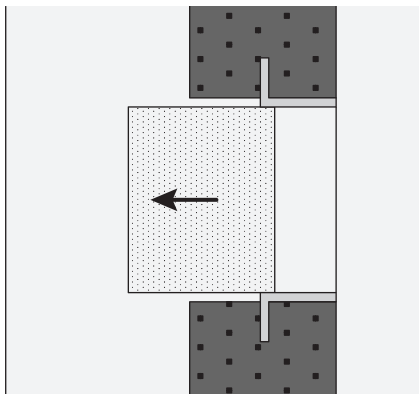

Figure 3

When all shuttering and other formwork has been removed, the polystyrene mould must be removed prior to electrical installation.

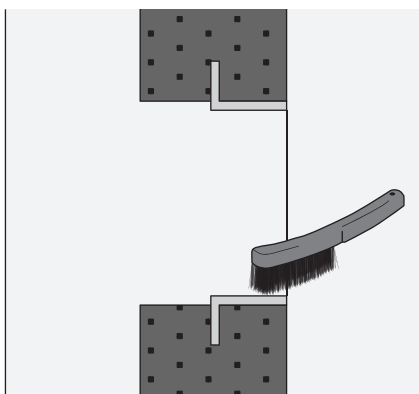

Figure 4

The transit aperture should be cleaned to remove any concrete or other debris that may have contaminated the apertures internal faces.

BOLTED

Sleeves can be bolted to floors and walls in either of the options showed below (CBO Sleeves, open version, can not be reverse fixed).

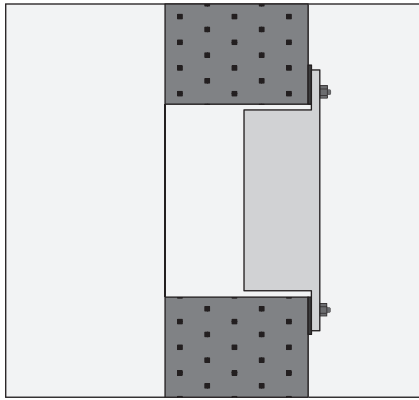

Figure 1.a

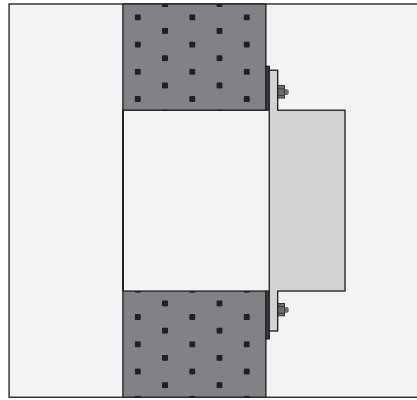

Figure 1.b

Size to fixing holes and type of fastener is to be established by the civil contractor dependent on size of sleeve weight and structure to which it is to be fixed.

When fixing sleeves to concrete/brick type structure care should be taken if using expanding type fixings as they could burst into the aperture.

For bolted installations Intumescent Mastic or Hawke Fireproof Silicone (See page...78 catalogue) should be inserted between the sleeves flange and the structure.

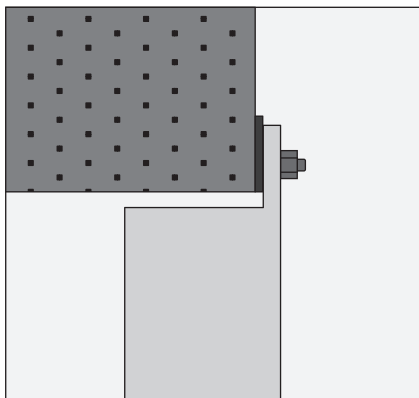

Figure 2.a

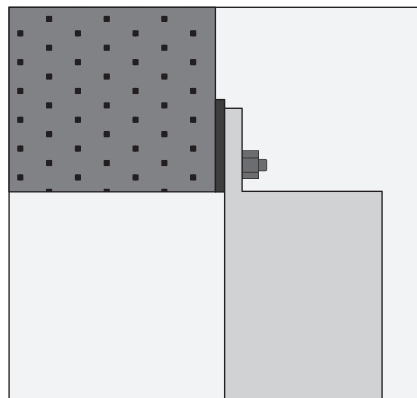

Figure 2.b

Prior to application of sealant ensure that faces to be sealed are dry and free from grease and any loose material, ensure that transit sleeve mates up with any fixings/holes already present checking especially the apertures over which the sleeve is to be mounted. (See minimum aperture dimensions table).

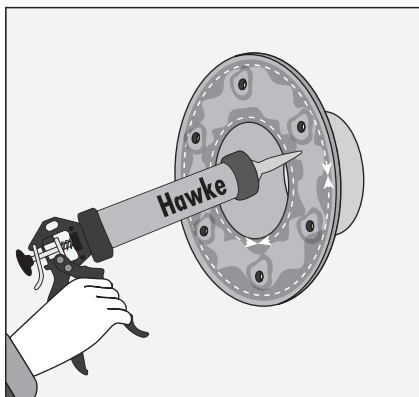

Figure 3.a

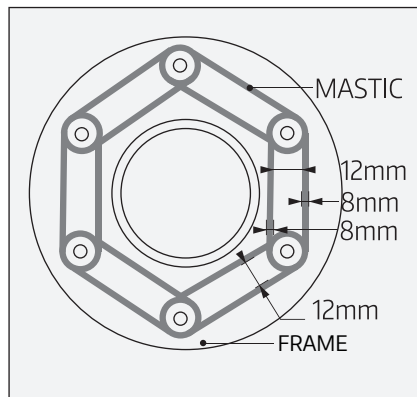

Figure 3.b

Cut nozzle on Mastic/Silicone tube to produce a bead diameter of approximately 8mm.

Apply two parallel rows of mastic and run a bead of mastic around each hole, as show below.

The Mastic/Silicone can be applied to front or rear of the frame dependant on the installation.
See Fig.1 and Fig.2.

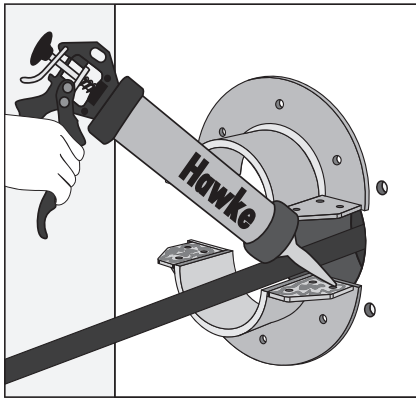

Figure 4.a

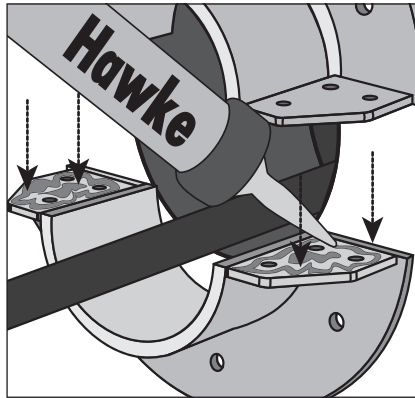

Figure 4.b

If CBO open sleeve is used, Mastic/Silicone should be applied also in all bolting areas of the removable end as showed below.

The sleeve can now be placed over its fixings and fasteners tightened to clamp the sleeve to the wall/floor.

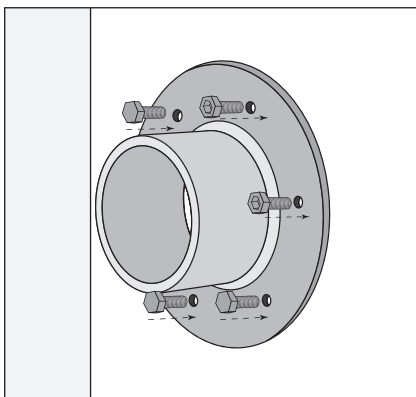

Figure 5

When tightened up to the required amount, the Mastic/Silicone should be faced off to the frame leaving a fillet of Mastic/Silicone around external edges of the frame.

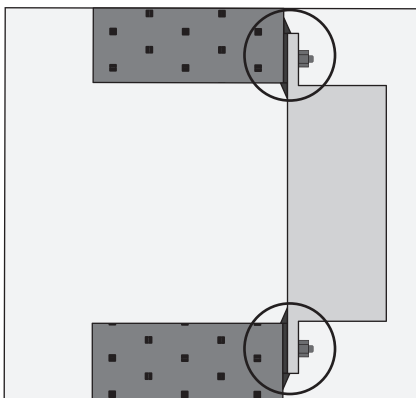
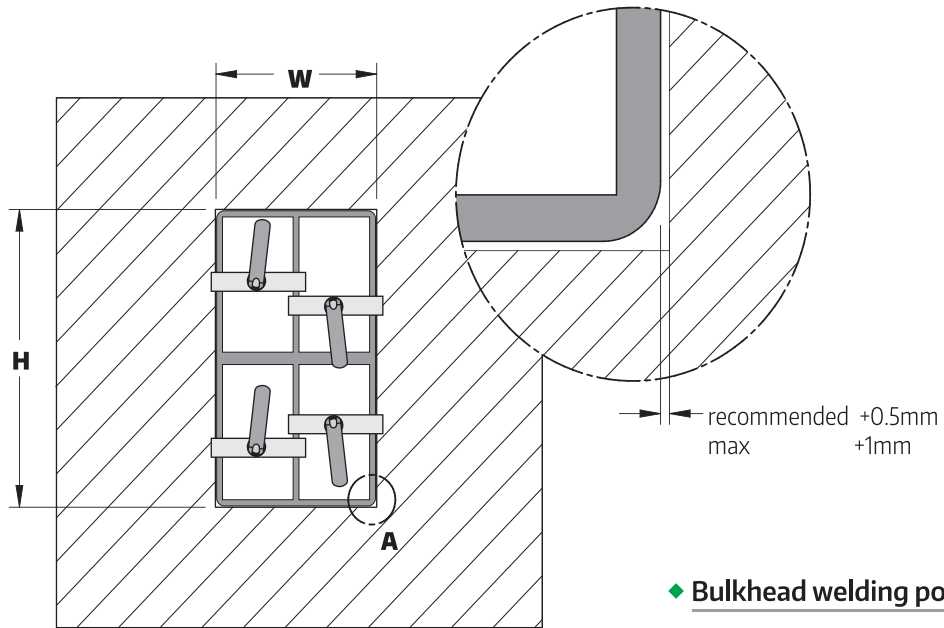

Figure 6

STANDARD WELDING INSTRUCTIONS

1. Check the measures of the precut hole and external dimensions of the frame. Recommended gap around the frame is in between 1mm and 2mm (0.5-1mm on every side of the frame). See frames dimension chart page...19



Deck welding positions

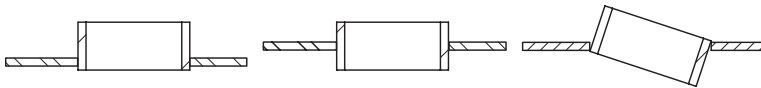

Bulkhead welding positions

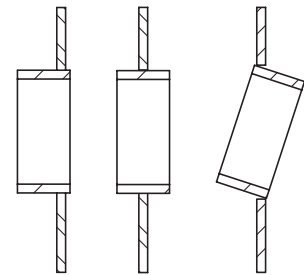

2. Tack weld on the front side, centring the frame onto the cut-out hole:

- ◆ Horizontally, one tack on every aperture.
- ◆ Vertically, one tack on every aperture and on every vertical division.

Check the gap measures all around the frame are maintained. If necessary, add weld material to the bulkhead/deck to reduce the gap (not to the frame)

Use HTS welding tool to prevent frame deformations during welding process.

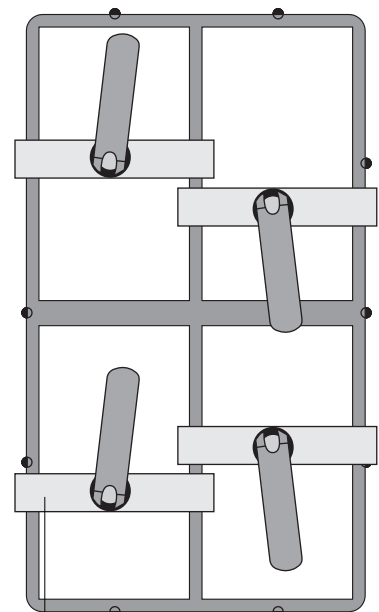
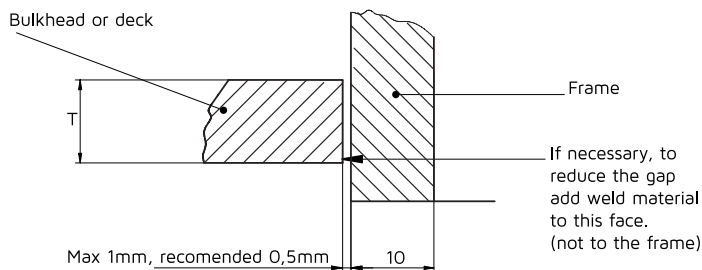

- ◆ Welding tool (See page..77) can be used to prevent deformation during the welding.

3. Start welding the frame with a sealing fillet weld on the backside. Follow appropriate welding sequence. This welding throat should not exceed 3mm.

The interpass temperature should not exceed 200°C for mild steel and aluminium and 150°C for stainless steel.

- ◆ Máx run lenght: { Mild Steel 200 mm
Stainless Steel 150 mm
Aluminium 200 mm

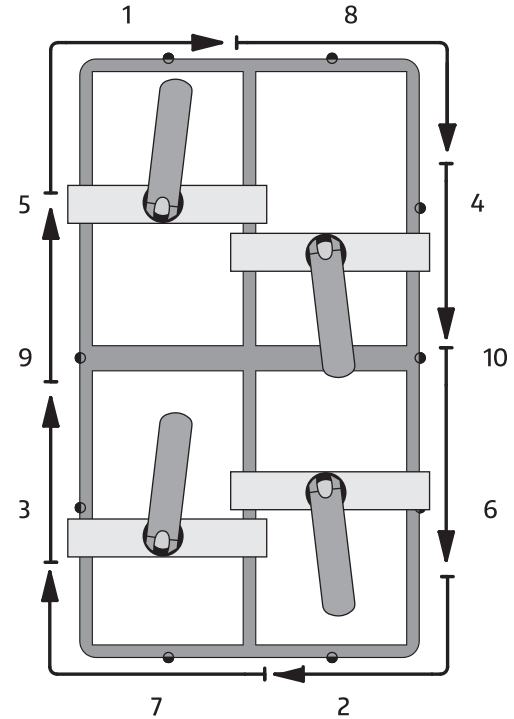
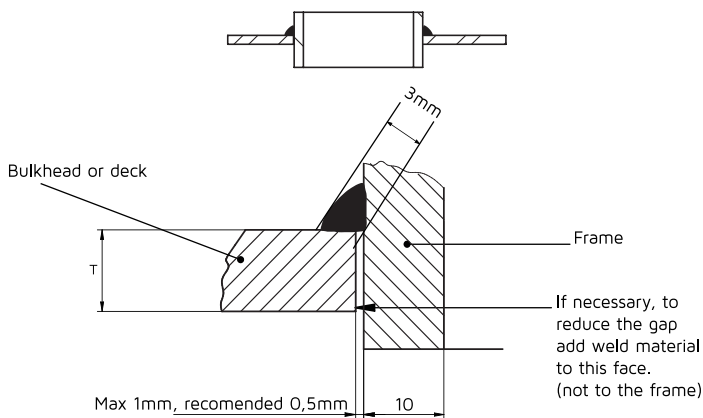

$$\text{Heat Input (KJ/mm)} = \frac{V \cdot I \cdot \eta}{\text{vel} \cdot 1000}$$

V = volts / I = amperes / vel = mm/s

$$\eta = \begin{cases} 1 & \text{SMAW} \\ 0,8 & \text{GMAW / FCAW} \\ 0,6 & \text{GTAW} \end{cases}$$

	Máx. Heat Input (KJ/mm)		
	Mild Steel	Stainless Steel	Aluminium
a = 3 mm	1,2	1,1	2

4. Grind off weld tacks before start filled weld. Weld runs should not start or stop at a tack weld but should run over a tack.

Follow same welding sequence for correct procedure.

The interpass temperature should not exceed 200°C for mild steel and aluminium and 150°C for stainless steel.

This welding throat should not exceed following values:

- T > 7mm a=5mm
T ≤ 7mm a=4mm

- ◆ Máx run lenght: { Mild Steel 200 mm
Stainless Steel 150 mm
Aluminium 200 mm

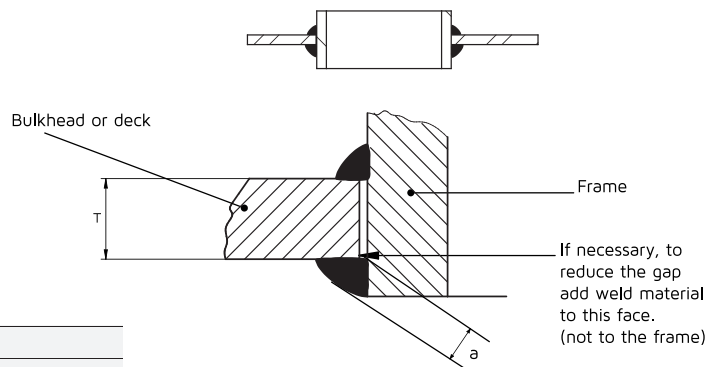

	Máx. Heat Input (KJ/mm)		
	Mild Steel	Stainless Steel	Aluminium
a = 4 mm	1,2	1,1	2
a = 5 mm	1,4	1,1	2

SLEEVES WELDING INSTRUCTIONS

1. Check the measures of the precut hole and external dimensions of the frame. Recommended gap around the frame is in between 1mm and 2mm (0.5-1mm on every side of the frame). See frames dimension chart page...56

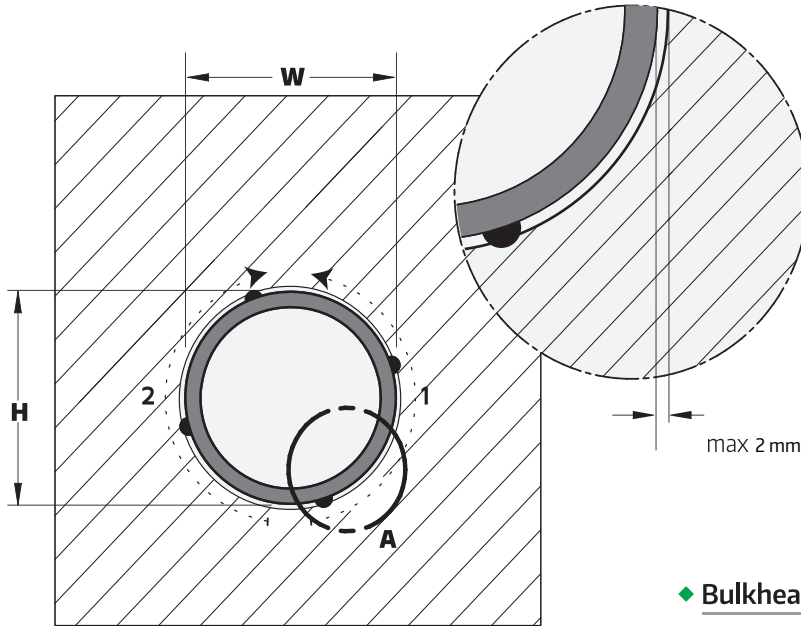

Bulkhead welding positions

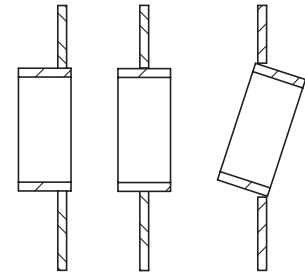

Deck welding positions

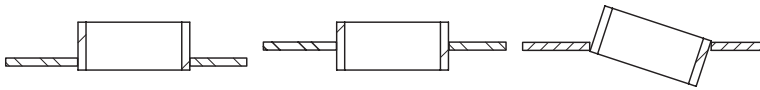

2. Tack weld on the front side, centring the frame onto the cut-out hole:

Check the gap measures all around the frame are maintained. If necessary, add weld material to the bulkhead/deck to reduce the gap (not to the frame)

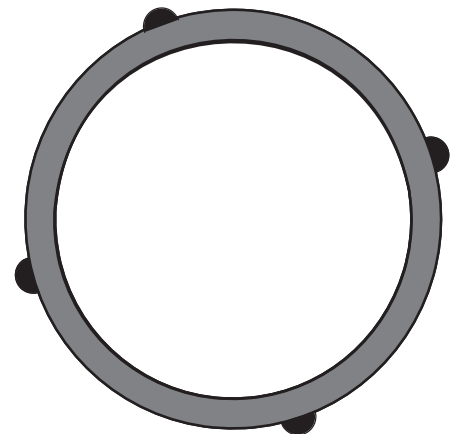
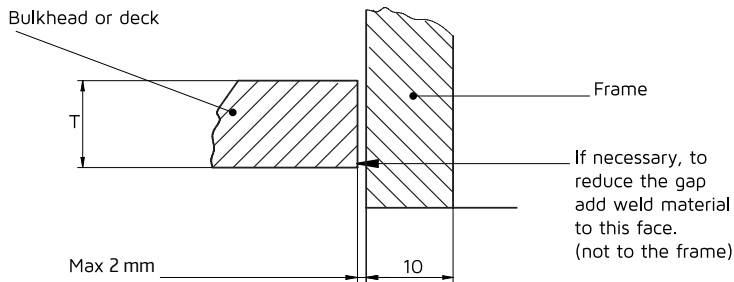

3. Start welding the frame with a sealing fillet weld on the backside. Follow appropriate welding sequence. This welding throat should not excess of 3mm.

The interpass temperature should not exceed 200°C for mild steel and aluminium and 150°C for stainless steel.

- ◆ Máx run lenght: { Mild Steel 200 mm
Stainless Steel 150 mm
Aluminium 200 mm

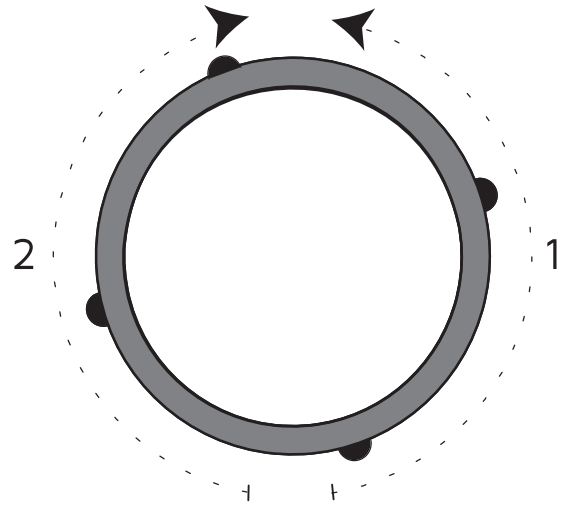
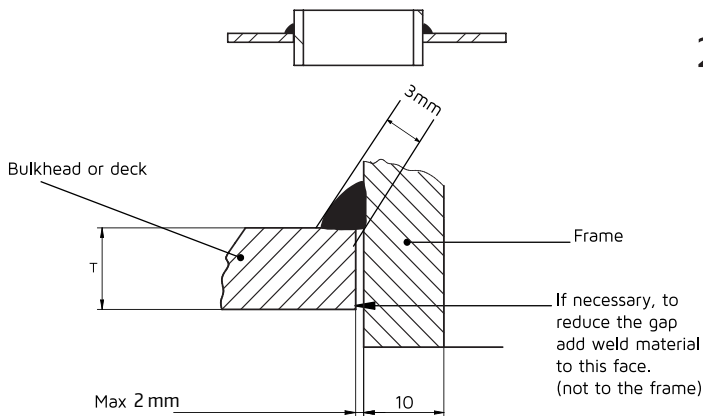

$$\text{Heat Input (KJ/mm)} = \frac{V \cdot I \cdot \eta}{\text{vel} \cdot 1000}$$

V = volts / I = amperes / vel = mm/s

$$\eta = \begin{cases} 1 & \text{SMAW} \\ 0,8 & \text{GMAW / FCAW} \\ 0,6 & \text{GTAW} \end{cases}$$

	Máx. Heat Input (KJ/mm)		
	Mild Steel	Stainless Steel	Aluminium
a = 3 mm	1,2	1,1	2

4. Grind off weld tacks before start filled weld. Weld runs should not start or stop at a tack weld but should run over a tack.

Follow same welding sequence for correct procedure.

The interpass temperature should not exceed 200°C for mild steel and aluminium and 150°C for stainless steel.

This welding throat should not excess following values:

- T > 7mm a=5mm
T ≤ 7mm a=4mm

- ◆ Máx run lenght: { Mild Steel 200 mm
Stainless Steel 150 mm
Aluminium 200 mm

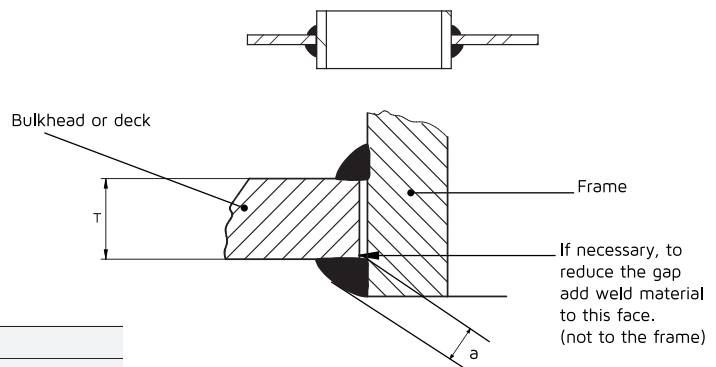

	Máx. Heat Input (KJ/mm)		
	Mild Steel	Stainless Steel	Aluminium
a = 4 mm	1,2	1,1	2
a = 5 mm	1,4	1,1	2

HMFx WELDING INSTRUCTIONS

1. Tack weld on the front side, centring the frame onto the cut-out hole.
Same as step 2 of standard welding instructions (see page...150).

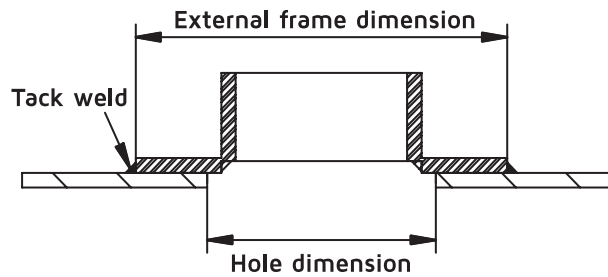
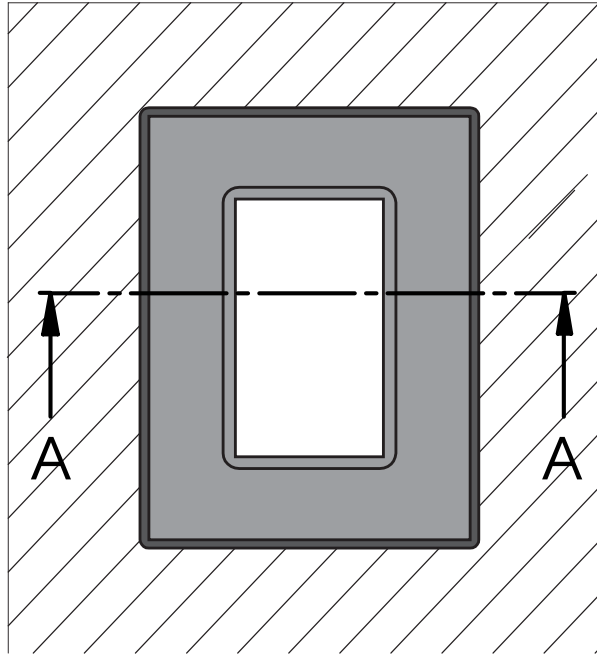

Minimum hole dimension	=	(external HMFx dimensions)	less 110mm
Maximum hole dimension	=	(external HMFx dimensions)	less 10mm

2. Grind off weld tacks before start filled weld. Weld runs should not start or stop at a tack weld but should run over a tack.

Follow same welding sequence for correct procedure.

The interpass temperature should not exceed 200°C for mild steel and aluminium and 150°C for stainless steel.

This welding throat should not exceed following values:

T > 7mm a=5mm
 T ≤ 7mm a=4mm

◆ Máx run lenght: { Mild Steel 200 mm
 Stainless Steel 150 mm
 Aluminium 200 mm

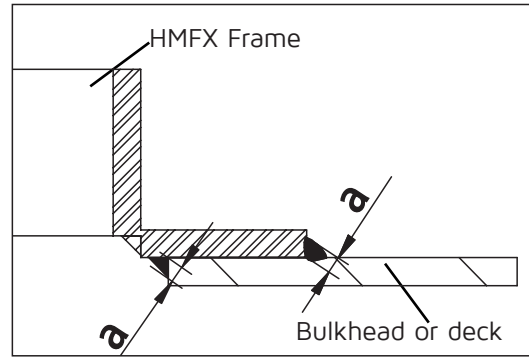

$$\text{Heat Input (KJ/mm)} = \frac{V \cdot I \cdot \eta}{\text{vel} \cdot 1000} \quad \eta = \begin{cases} 1 & \text{SMAW} \\ 0,8 & \text{GMAW / FCAW} \\ 0,6 & \text{GTAW} \end{cases}$$

V = volts / I = amperes / vel = mm/s

	Máx. Heat Input (KJ/mm)		
	Mild Steel	Stainless Steel	Aluminium
a = 4 mm	1,2	1,1	2
a = 5 mm	1,4	1,1	2

→ **HMOX** Welding installation guide:

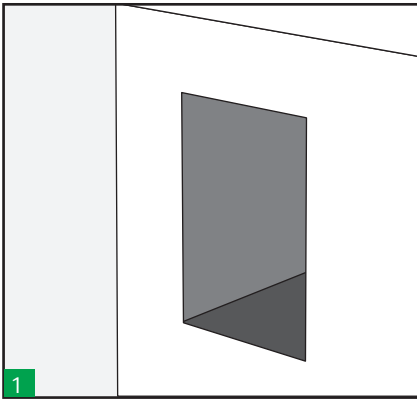

1

Ensure Hole cut is dimensionally in accordance with the standard HMX frames welding instructions

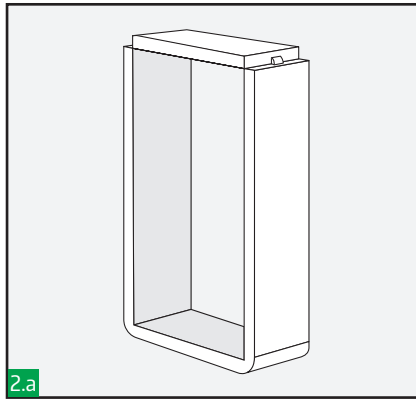

2.a

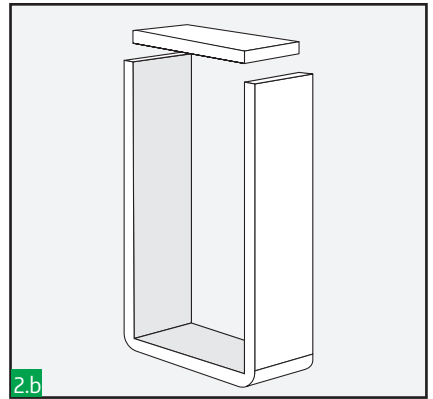

2.b

Break tack welds and remove end piece from the frame.

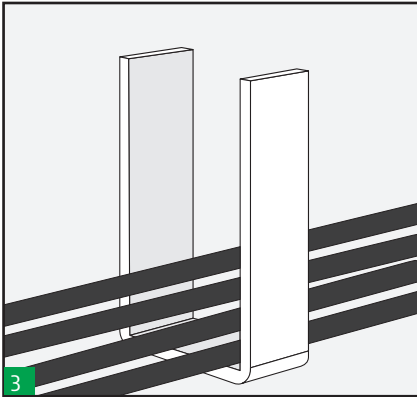

3

Place frame around cables. Tack weld end piece back into place. End piece should be centred in the lateral bars.

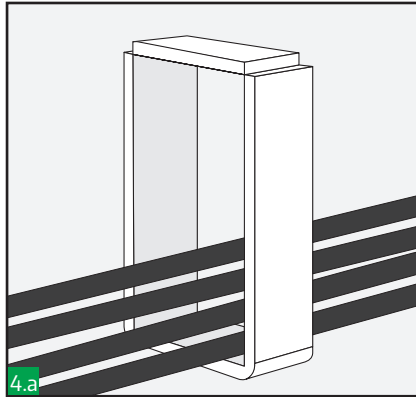

4.a

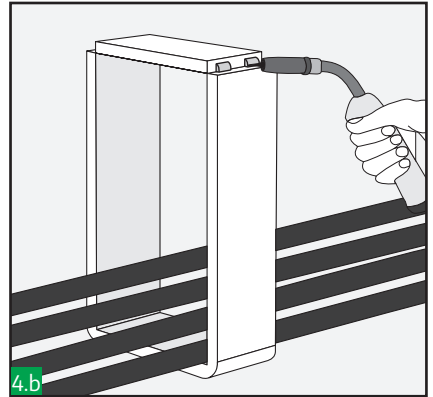

4.b

Tack weld end piece back into place. End piece should be centred in the lateral bars.

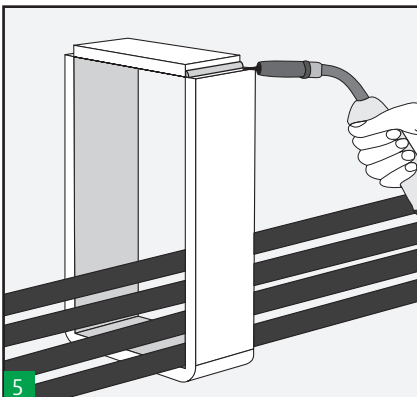

5

Run root fillet weld for full width of frame.

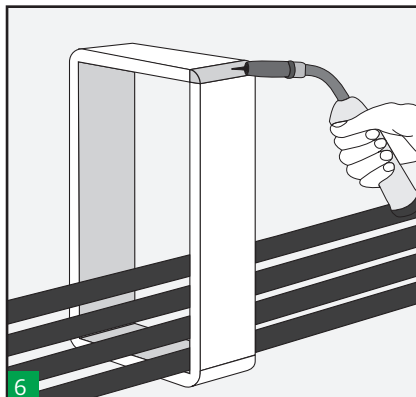

6

Final weld to form full radius at corners of frame.

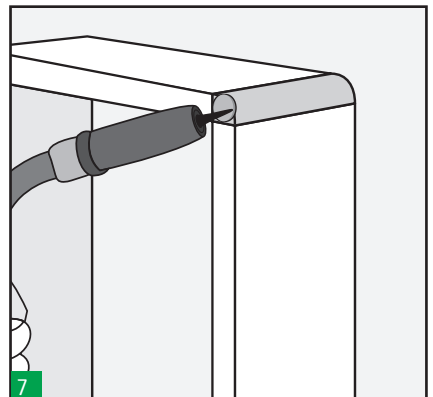

7

Clean both ends of weld/frame and spot weld them to ensure seal. Weld should not penetrate inside the corner of the frame.

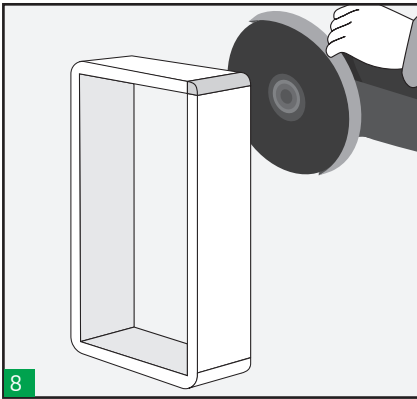

8

Dress welds.

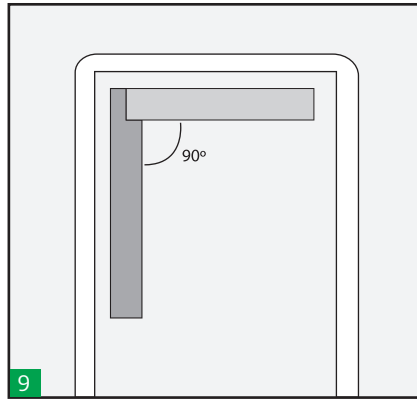

9

Check for squareness and parallelism.

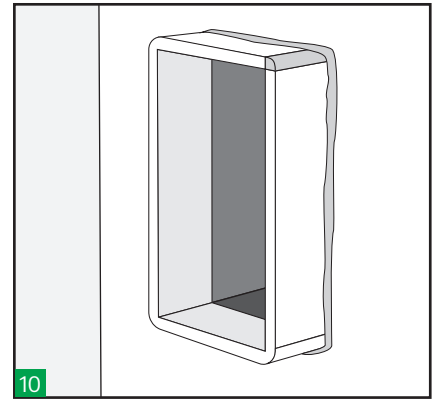

10

Weld frame in position in accordance with Rectangular frame HMX welding instructions and seal the frame in accordance to rectangular system installation guide.

◆ Notes

Leave the system at least 24 hours before apply pressure.
For disassembly see disassembly installation instructions.

◆ Sealing Area

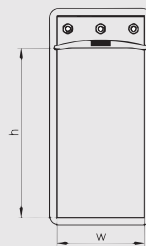

APERTURE SIZE	SEALING AREA (w x h)
1	60 x 60
2	120 x 60
3	60 x 120
4	120 x 120
5	60 x 180
6	120 x 180
7	60 x 240
8	120 x 240

→ **RECTANGULAR STANDARD** installation and inspection checks guidelines:

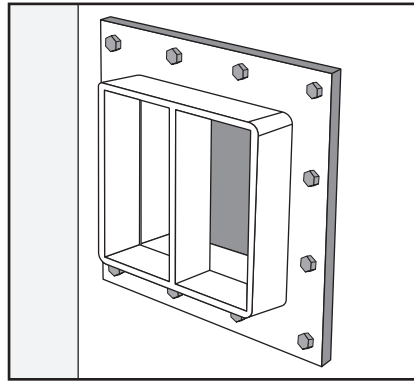
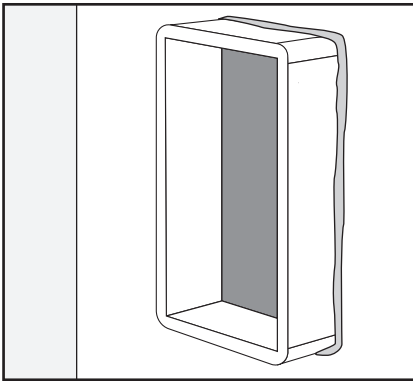

Check that Hawke Frame has been used in the installation, that it has been properly installed (welded/bolted) and that it has not mechanical or corrosion damage.

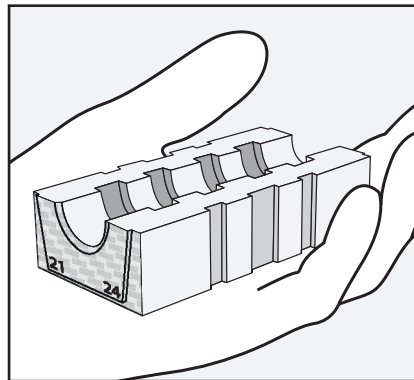
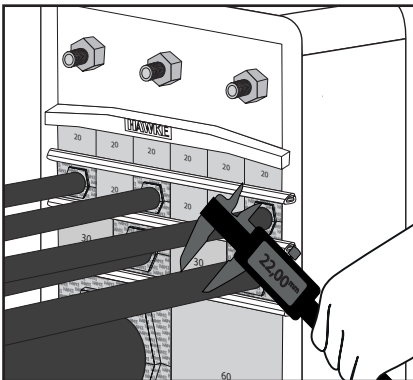

Measure the outer diameter of the cable and ensure that the diameter is within the cable range marked on the front of the block or by the colour code of the block.

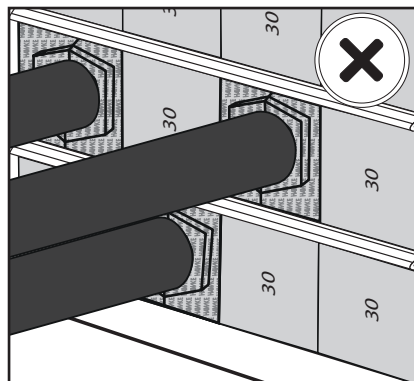
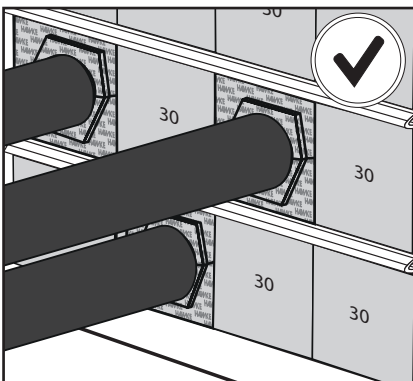

Check the correct orientation of the blocks.

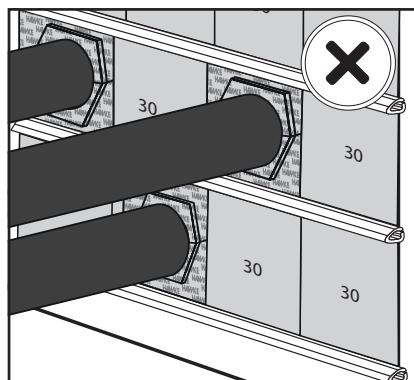
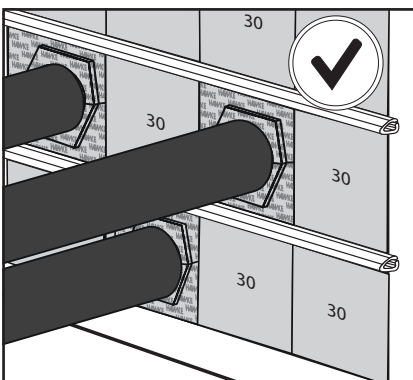

Check that there are a stayplate between each row of blocks and there are not stayplate between the bottom row of blocks and the frame.

Check that all block are installed in position between the stayplates retention lips.

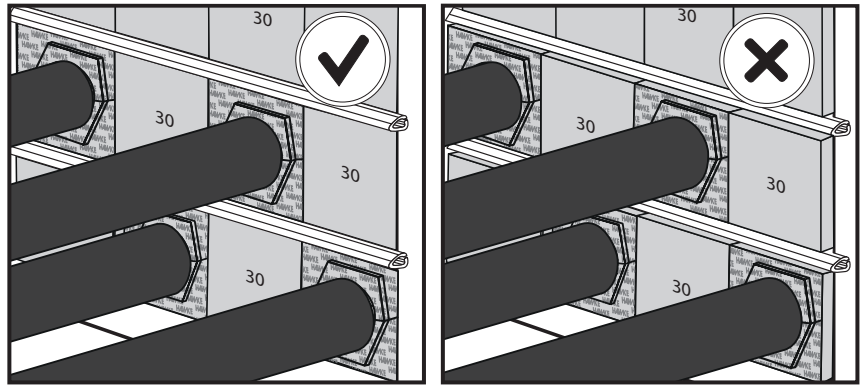

Check that Hawke Lubricant has been used during the installation.

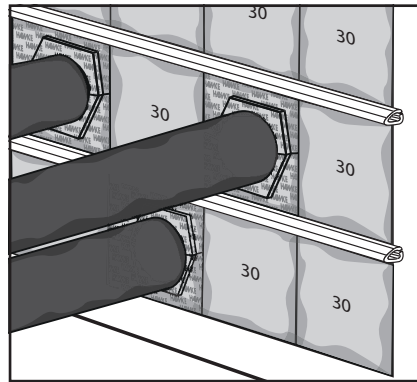

Check that there are sufficient blocks installed into the frame to cover the sealing area defined for each size of frame.

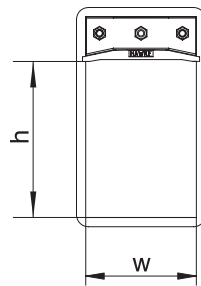

APERTURE SIZE	SEALING AREA (w x h)
1	60 x 60
2	120 x 60
3	60 x 120
4	120 x 120
5	60 x 180
6	120 x 180
7	60 x 240
8	120 x 240

Check that the right tightening of the bolts have been performed (approximately 10-12 mm of thread on each bolt should protrude from the nut).

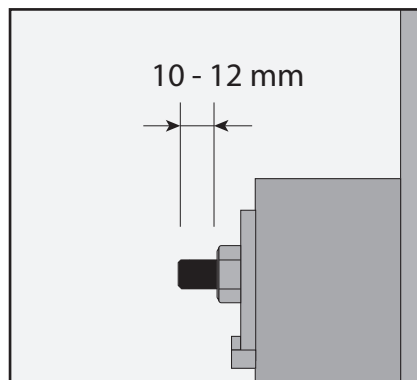

Notes

- Leave the system at least 24 hours before apply pressure.
- If transit application is in excess of 3,5 bar, high pressure stayplates should be used together with an extra 5mm sealing strip.

→ **ROUND HRTO/HRT** standard installation and inspection checks guidelines:

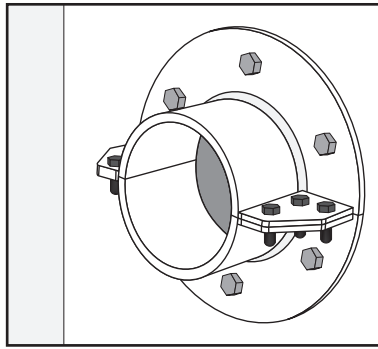
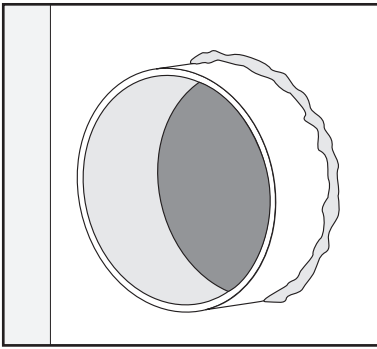

Check that Hawke Sleeve has been used in the installation, that it has been properly installed (welded/bolted) and that it has not mechanical or corrosion damage.

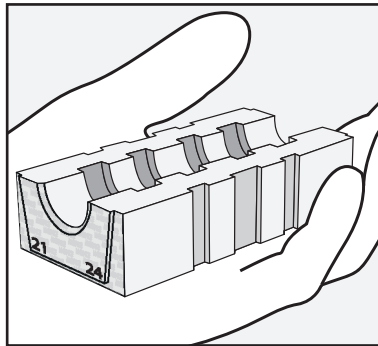
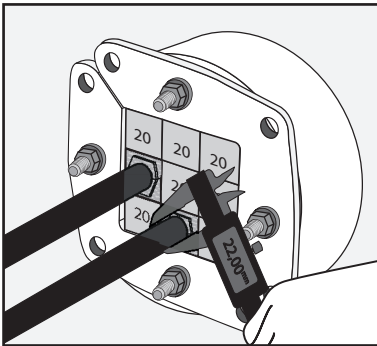

Measure the outer diameter of the cable and ensure that diameter is within the cable/pipe range marked on the front of the block or by the colour code of the block.

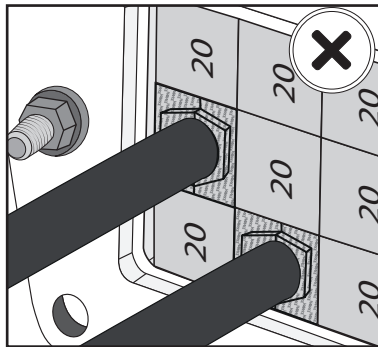
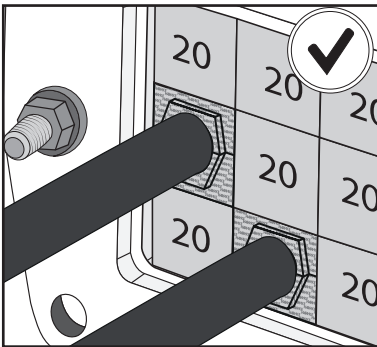

Check the correct orientation of the blocks.

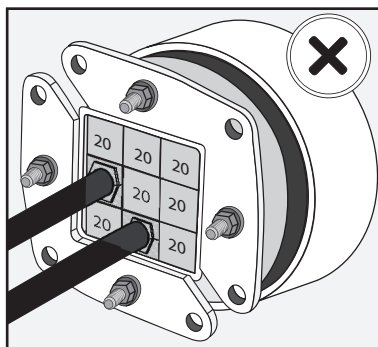
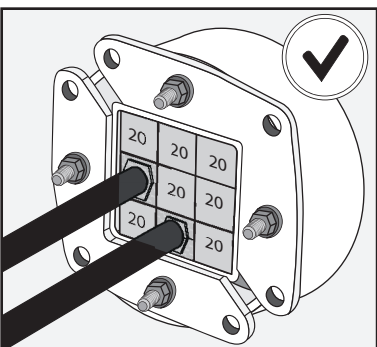

Check that the HRT/HRTO is completely inserted in the Sleeve/Aperture.

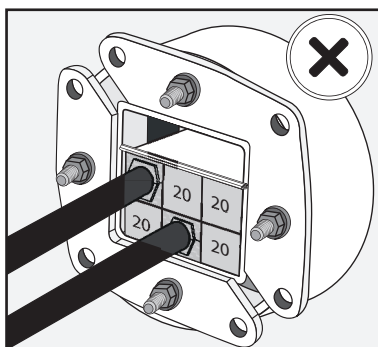
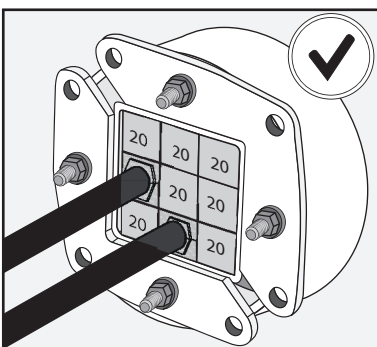

Check that stayplates have not be used in the installation.

Check that Hawke Lubricant has been used during the installation.

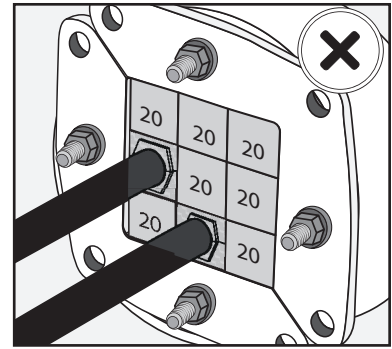
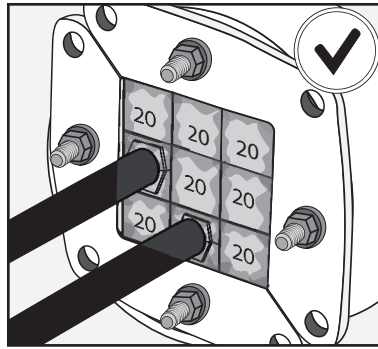

Check that front plates have been closed.

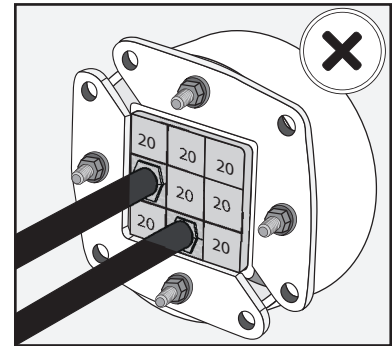
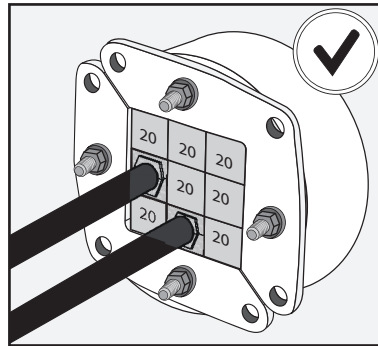

Check that there are sufficient blocks installed into the frame to cover the sealing area defined for each size of frame.

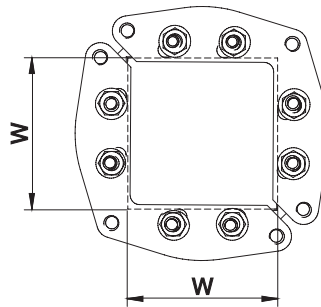

TYPE	SEALING AREA (mm)
HRTO-30	15x15
HRTO-40	20x20
HRTO-50	30x30
HRTO-70	40x40
HRTO-100	60x60
HRTO-125	80x80
HRTO-150	90x90
HRTO-200	120x120

Check that the right tightening of the bolts have been performed (approximately 10 mm of thread on each bolt should protrude from the nut).

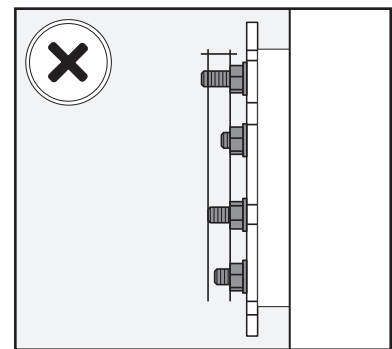
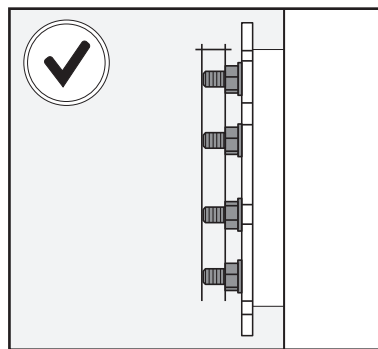

 Notes

Leave the system at least 24 hours before apply pressure.

Check that there are sufficient blocks installed into the frame to cover the sealing area defined for each size of frame.

→ **RECTANGULAR EMC** installation and inspection checks guidelines:

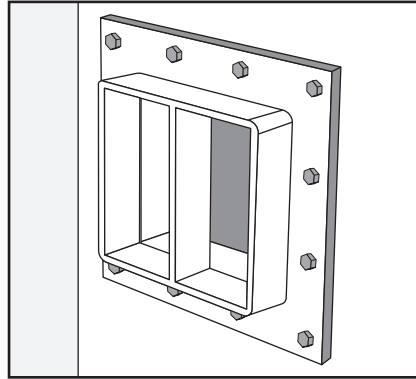
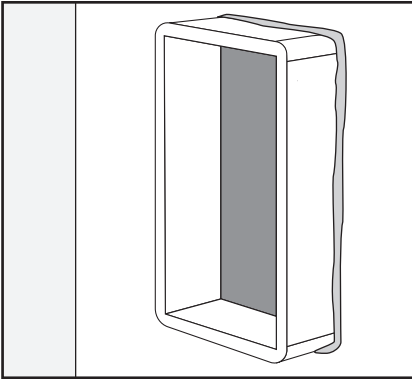

Check that Hawke Frame has been used in the installation, that it has been properly installed (welded/bolted) and that it has not mechanical or corrosion damage.

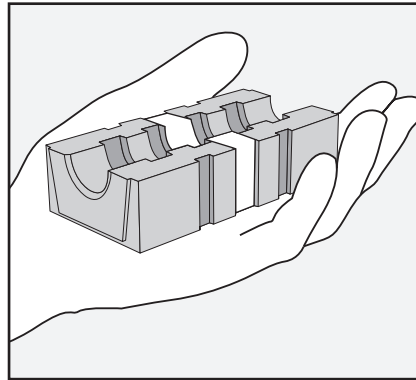
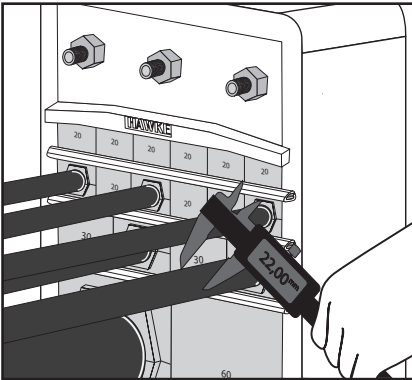

Measure the outer diameter of the cable and ensure that the diameter is within the cable range marked on the front of the block or by the colour code of the block.

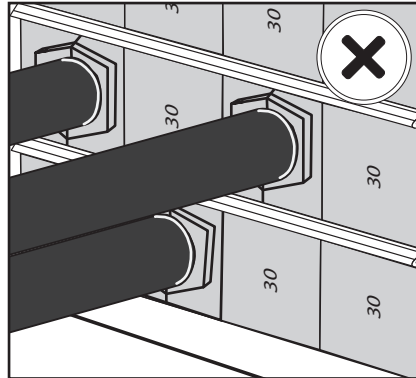
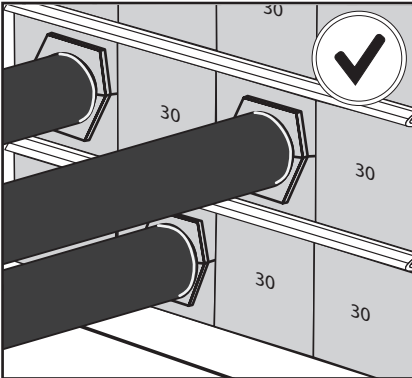

Check the correct orientation of the blocks.

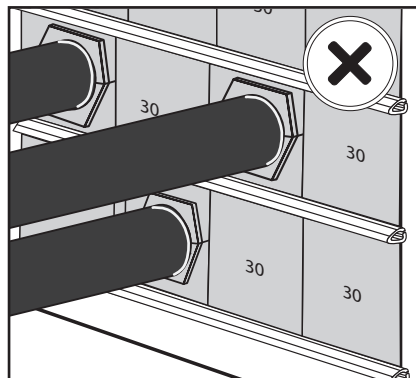
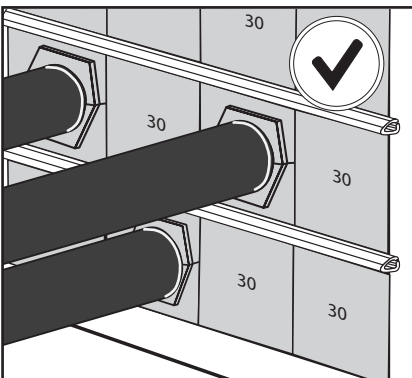

Check that there are a stayplate between each row of blocks and there are not stayplate between the bottom row of blocks and the frame.

Check that all block are installed in position between the stayplates retention lips.

Check that marks in all the cables are visible to be guarantee blocks and cable copper tapes are aligned.

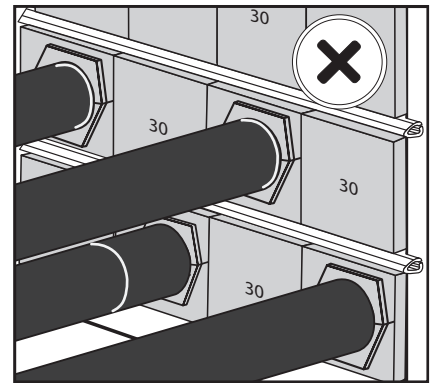
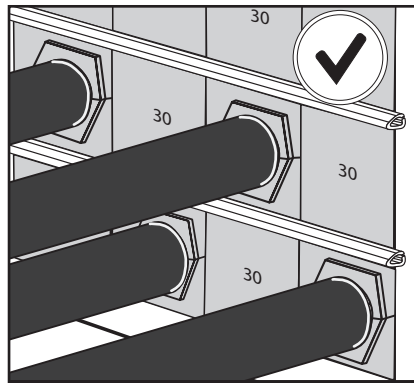

Check that Hawke Lubricant has been used during the installation.

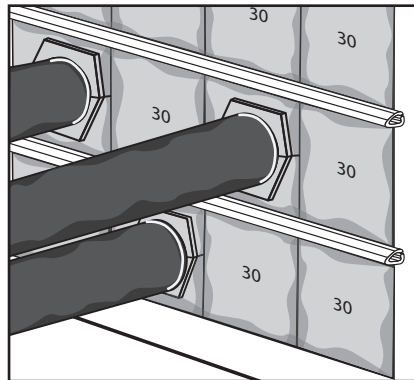

Check that there are sufficient blocks installed into the frame to cover the sealing area defined for each size of frame.

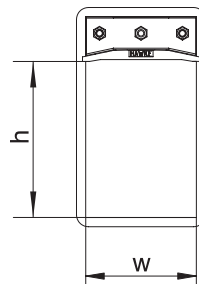

APERTURE SIZE	SEALING AREA (w x h)
1	60 x 60
2	120 x 60
3	60 x 120
4	120 x 120
5	60 x 180
6	120 x 180
7	60 x 240
8	120 x 240

Check that the right tightening of the bolts have been performed (approximately 10-12 mm of thread on each bolt should protrude from the nut).

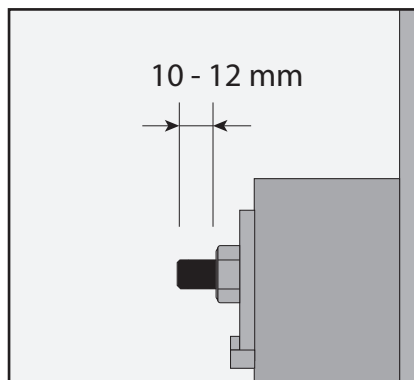

Notes

- Leave the system at least 24 hours before apply pressure.
- If transit application is in excess of 3,5 bar, high pressure stayplates should be used together with an extra 5mm sealing strip.

→ **ROUND EMC HRTO/HRT** standard installation and inspection checks guidelines:

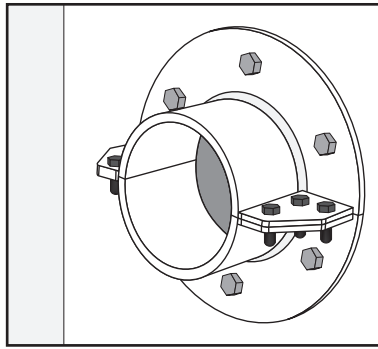
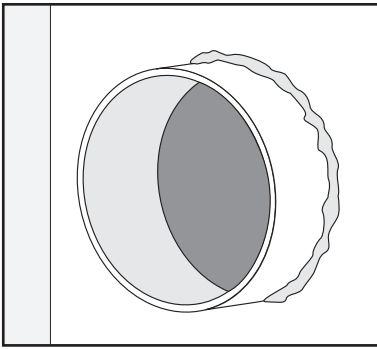

Check that Hawke Sleeve has been used in the installation, that it has been properly installed (welded/bolted) and that it has not mechanical or corrosion damage.

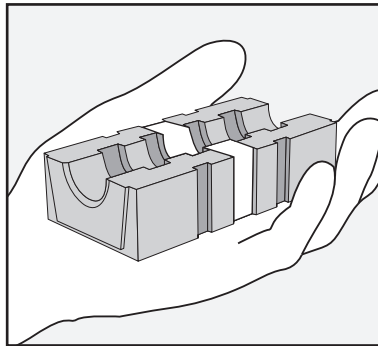
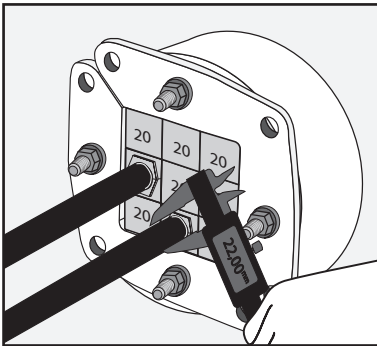

Measure the outer diameter of the cable and ensure that diameter is within the cable/pipe range marked on the front of the block or by the colour code of the block.

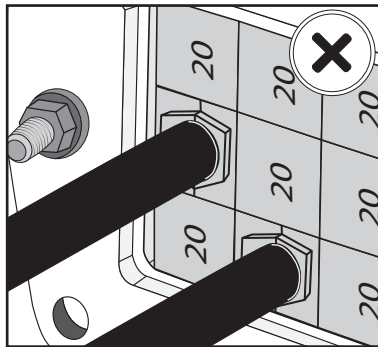
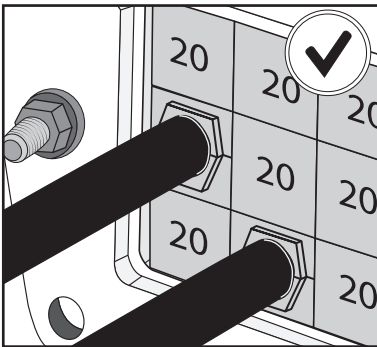

Check the correct orientation of the blocks.

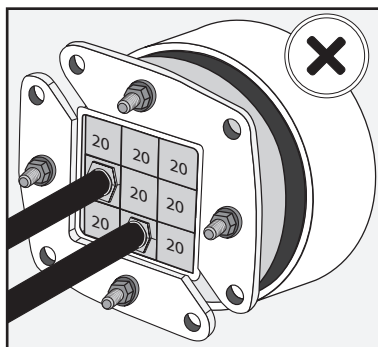
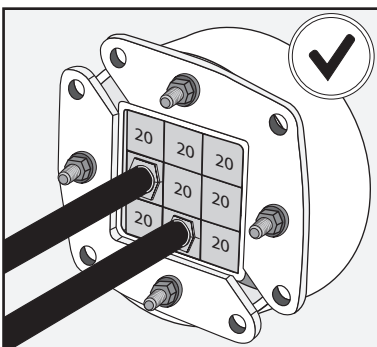

Check that the HRT/HRTO is completely inserted in the Sleeve/Aperture.

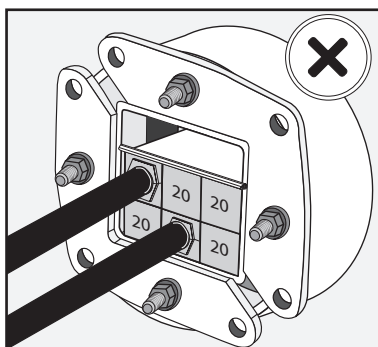
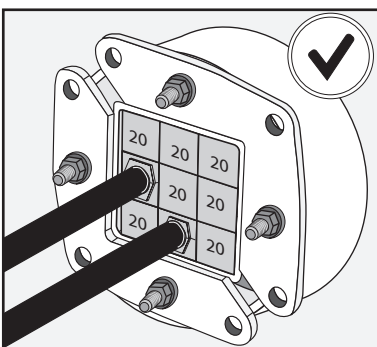

Check that stayplates have not be used in the installation.

Check that Hawke Lubricant has been used during the installation.

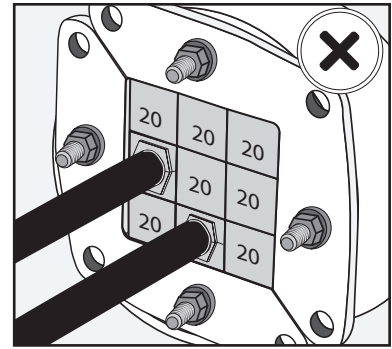
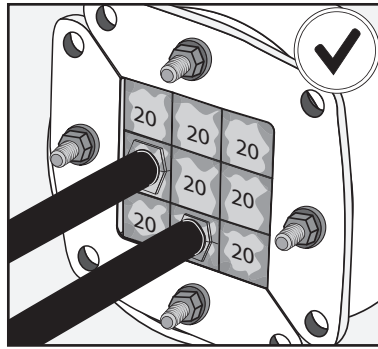

Check that front plates have been closed.

Check that marks in all the cables are visible to be guarantee blocks and cable copper tapes are aligned.

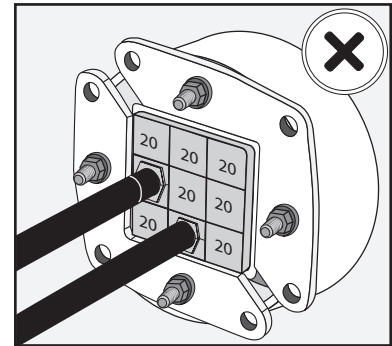
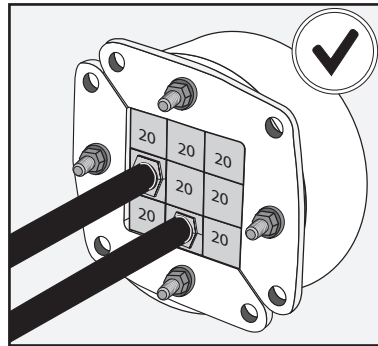

Check that there are sufficient blocks installed into the frame to cover the sealing area defined for each size of frame.

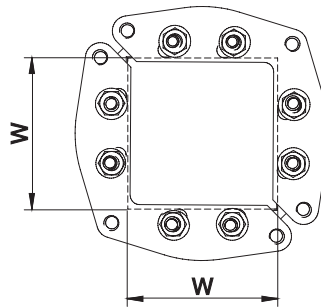

TYPE	SEALING AREA (mm)
HRTO-30	15x15
HRTO-40	20x20
HRTO-50	30x30
HRTO-70	40x40
HRTO-100	60x60
HRTO-125	80x80
HRTO-150	90x90
HRTO-200	120x120

Check that the right tightening of the bolts have been performed (approximately 10 mm of thread on each bolt should protrude from the nut).

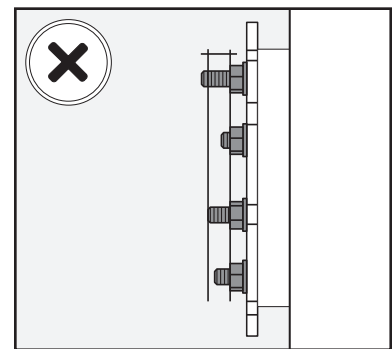
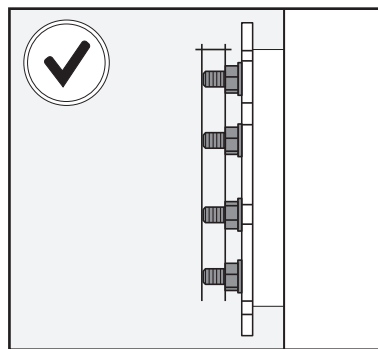

 Notes

Leave the system at least 24 hours before apply pressure.

Check that there are sufficient blocks installed into the frame to cover the sealing area defined for each size of frame.

→ **ROUND HRST STANDARD** installation and inspection checks guidelines:

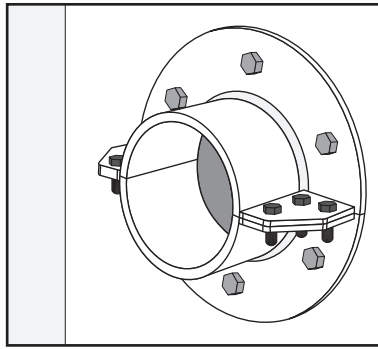
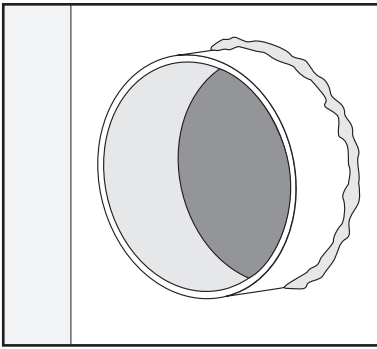

Check that Hawke Sleeve has been used in the installation, that it has been properly installed (welded/bolted) and that it has not mechanical or corrosion damage.

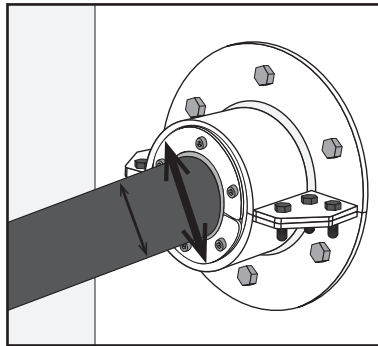

Check the inside diameter of the sleeve and the outside diameter of the cable/pipe to verify that it is within the range of selected HRST.

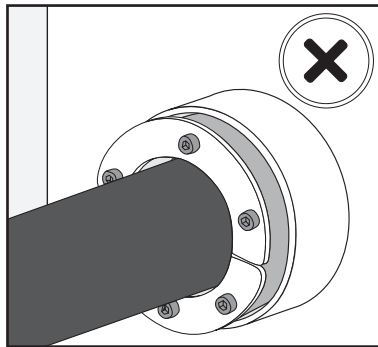
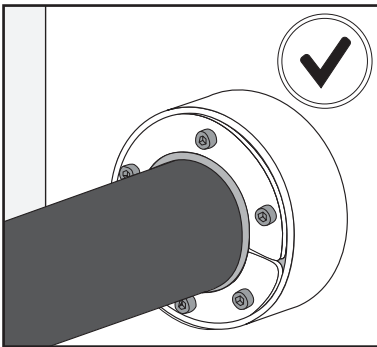

Check that the HRST is completely inserted in the Sleeve/Aperture.

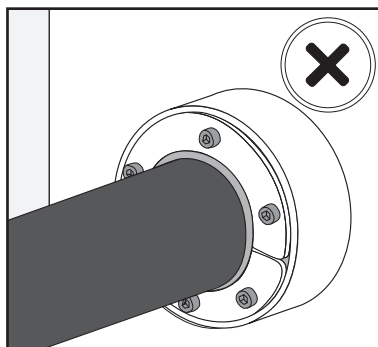
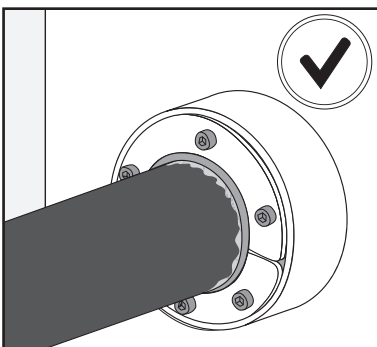

Check that Hawke Lubricant has been used during the installation.

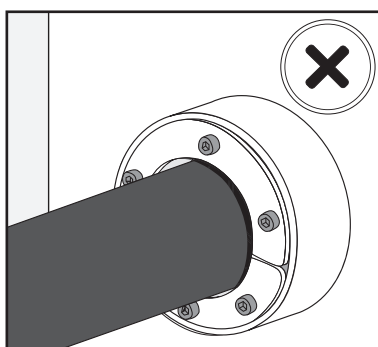
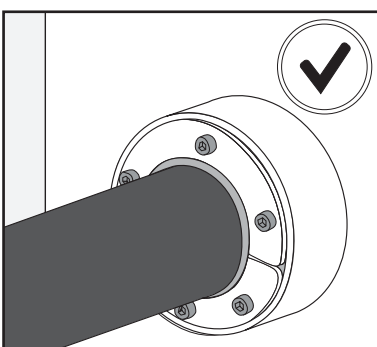

Check that all the bolts has been tightened similarly and do not exist gaps between the cable/pipe and the HRST.

→ **ROUND HRST MULTIHOLE** installation and inspection checks guidelines:

Check that Hawke Sleeve has been used in the installation, that it has been properly installed (welded/bolted) and that it has not mechanical or corrosion damage.

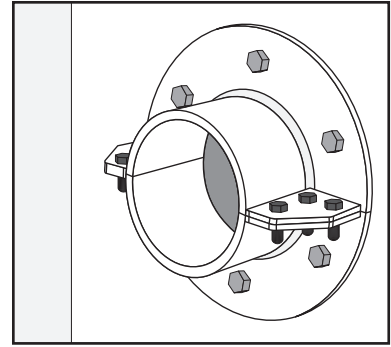
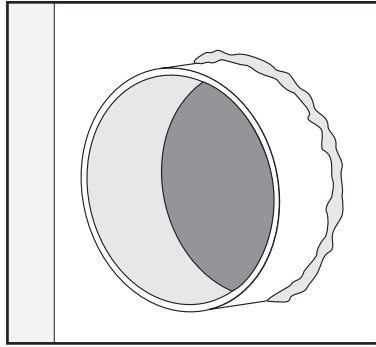

Check the inside diameter of the sleeve and the outside diameter of the cable/pipe to verify that it is within the range of selected HRST.

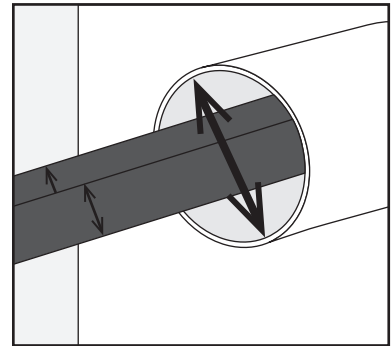

Check that the HRST is completely inserted in the Sleeve/Aperture.

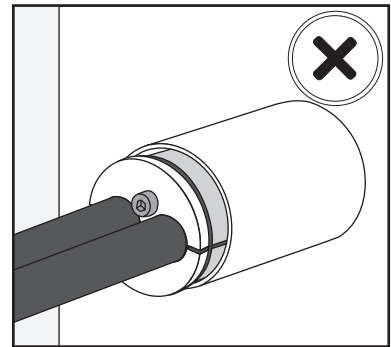
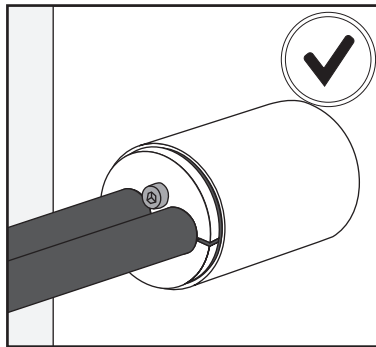

Check that Hawke Lubricant has been used during the installation.

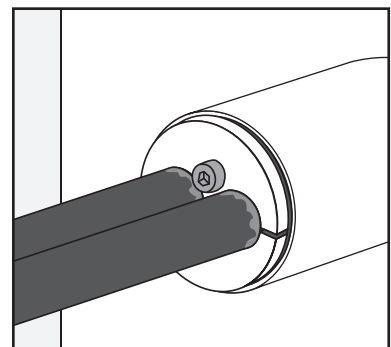

Check that all the bolts has been tightened similarly and do not exist gaps between the cable/pipe and the HRST.

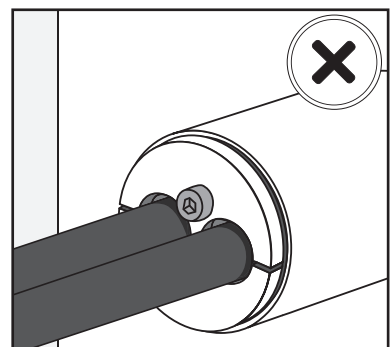
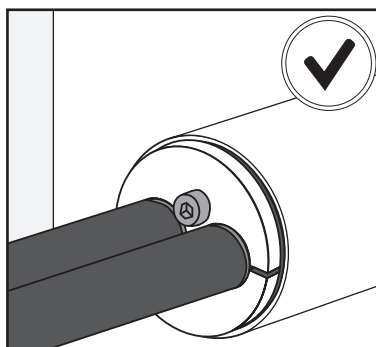

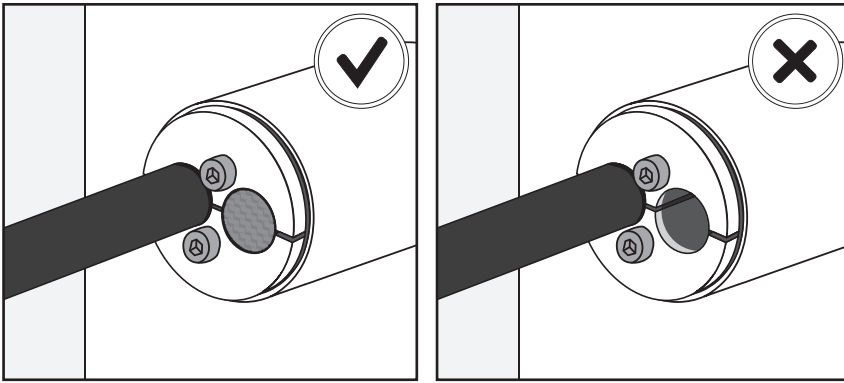

Check that every not occupied HRST holes are plugged with Hawke HRST plugs.



Notes

Leave the system at least 24 hours before apply pressure.

TEMPLATES

 **MARINE AND CIVIL RECTANGULAR STANDARD** Sealing template:

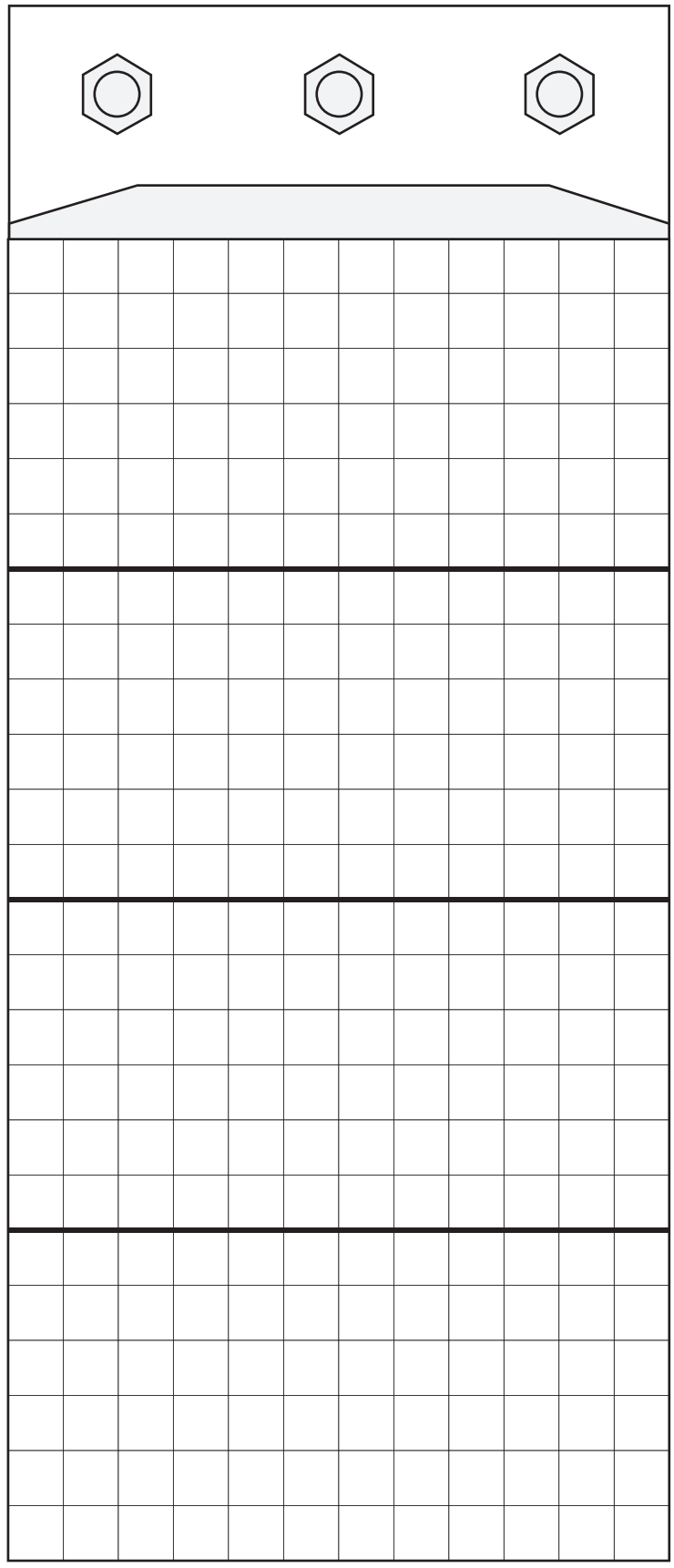
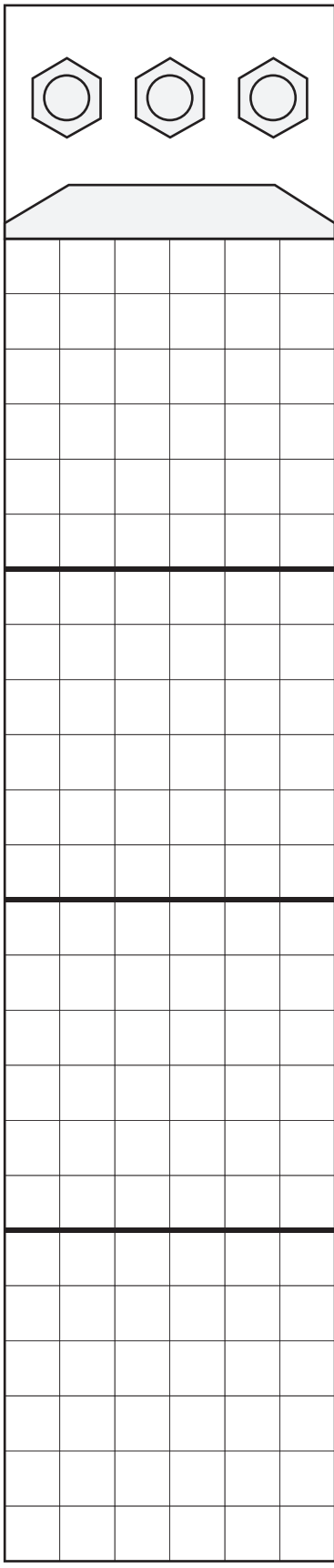

 → **ROUND CORNERS HMCX** Sealing Template:

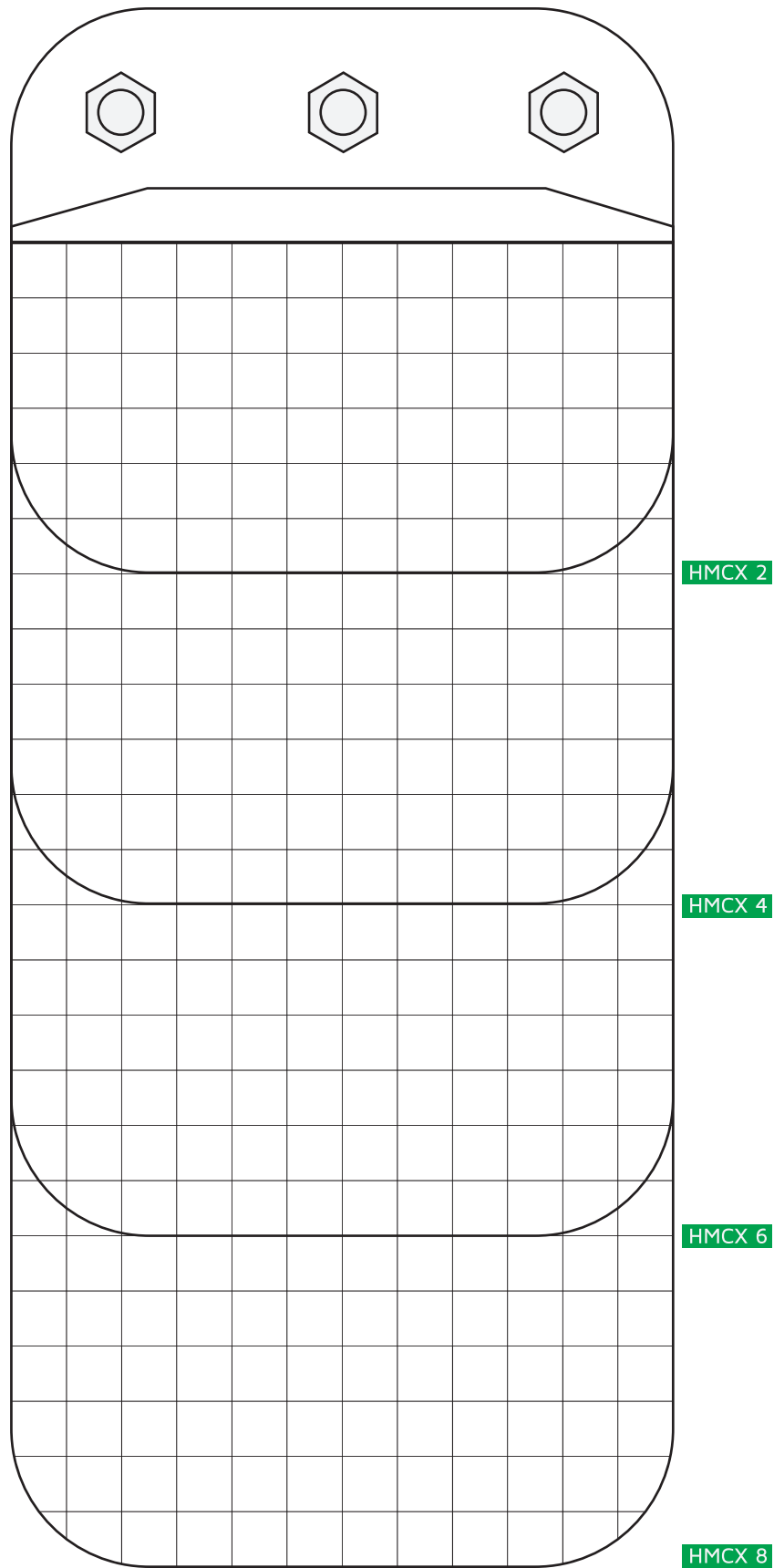

 → **CABINET SEAL H-DM** Sealing template:

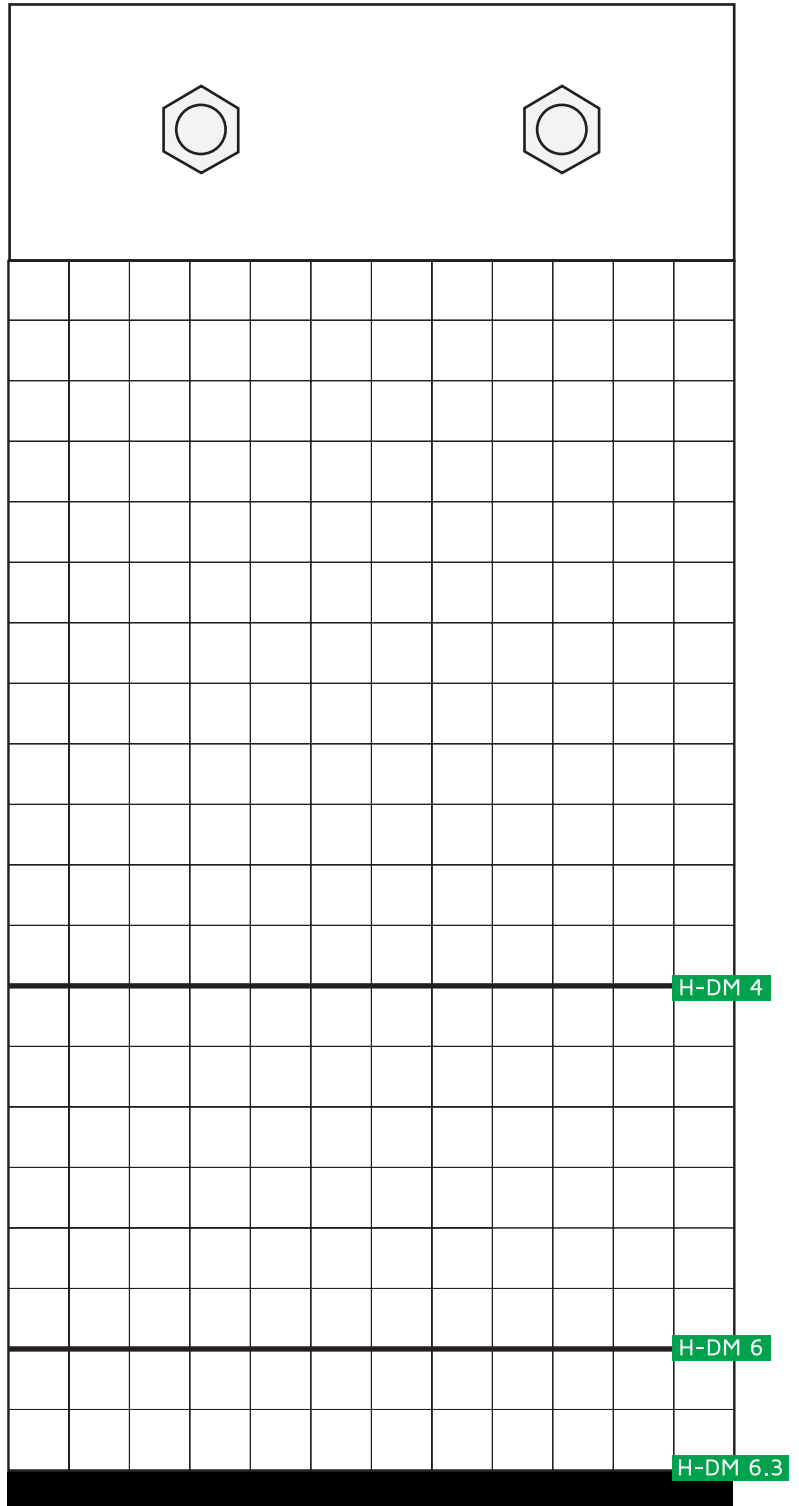
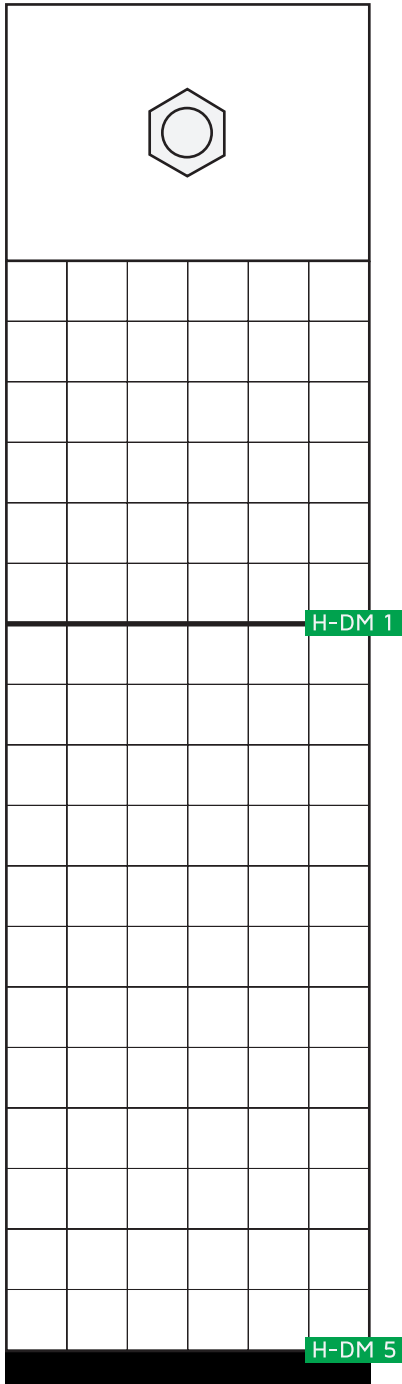

→ **ROUND TRANSITS HRTO** Sealing Template:

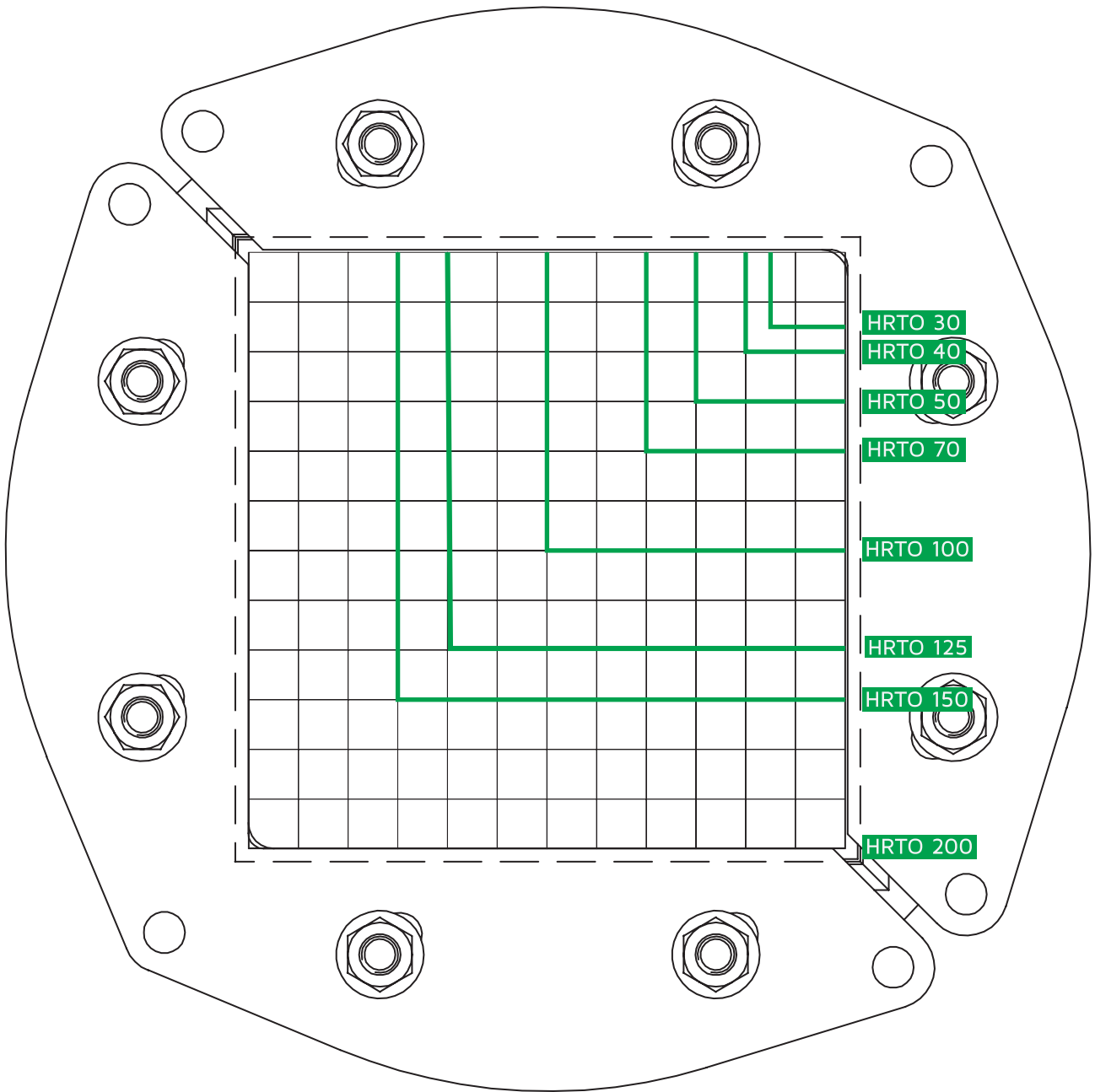

To the best of our knowledge the information contained in this brochure is accurate at the time of going to print and the company reserves the right to improve or modify any product illustrated without notifications. The company is unable to accept liability for any inaccuracies, errors or omissions that may exist. It is the customer's responsibility to ensure the product is suitable for their application.

This document and all copyright therein is the property of Hawke Transit system (A member of Fernandez Jove Group). This document shall be used for the propose which is provided and no reproduction or publication of the document may be made and no article may be manufactured or assembled in accordance with information contained in the document without prior written consent of the owner.



HAWKE[®] | Transit
System

HTS systems available worldwide through
our local suppliers network and sales points.

Prompt deliveries from our strategic
logistic centres and local stocks available
all around the world.



Head Office
HAWKE TRANSIT SYSTEM

P.E. Tanos-Viernoles · c/ La Espina, 44
39300 Torrelavega · Cantabria · SPAIN

sales@hawke-hts.com
+34 942 89 00 52

HAWKE TRANSIT SYSTEM
UK

NN10 6AG
Rushden · Northamptonshire · UK

sales@hawke-hts.com
+44 74 73 23 92 54



FERNÁNDEZ JOVE[®]
group

www.fjove.com
www.hawke-hts.com



WWW.HAWKE-HTS.COM

